

J. BOYER.
HORSE YOKE.

No. 193,316.

Patented July 24, 1877.

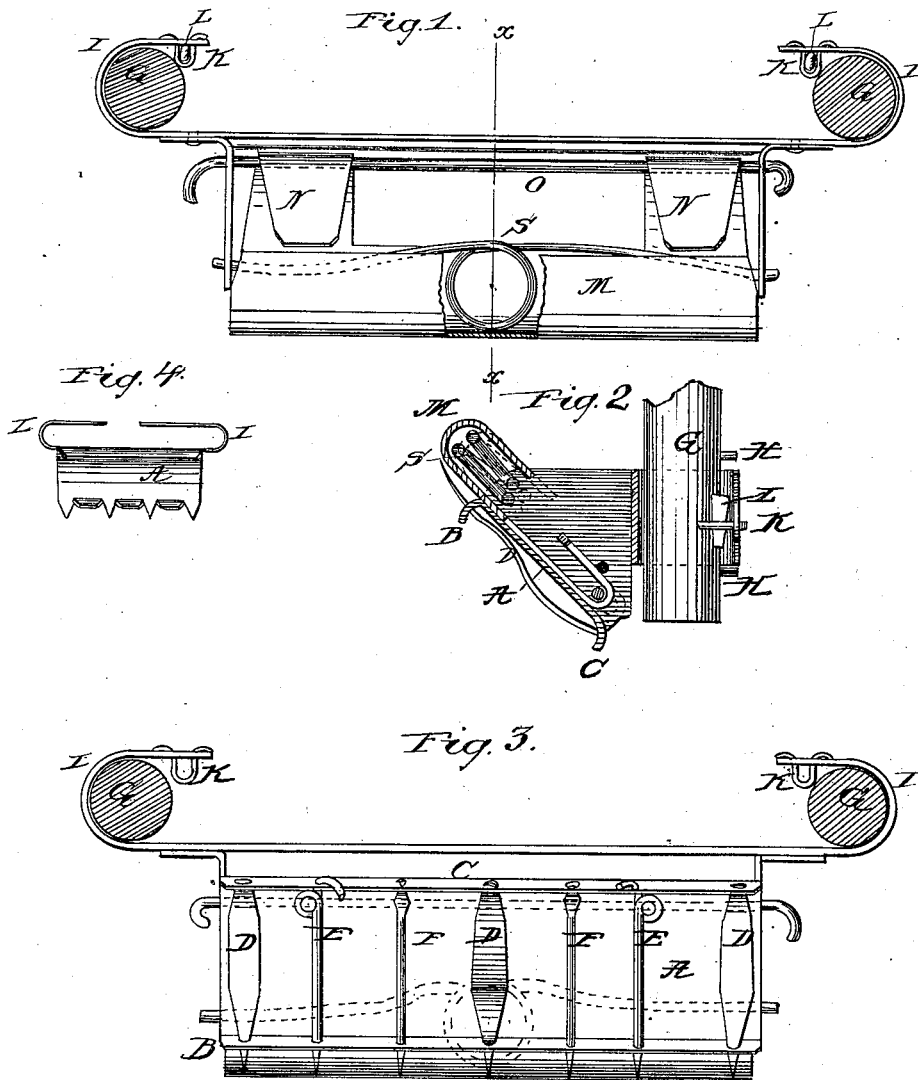

Witnesses.
And G. Dietrich
D. P. Low

Inventor
Jacob Boyer
by *Daniel Breed*

attty

UNITED STATES PATENT OFFICE.

JACOB BOYER, OF RURAL VALLEY, PENNSYLVANIA.

IMPROVEMENT IN HORSE-YOKES.

Specification forming part of Letters Patent No. **193,316**, dated July 24, 1877; application filed February 22, 1877.

To all whom it may concern:

Be it known that I, JACOB BOYER, of Rural Valley, in the county of Armstrong and State of Pennsylvania, have invented certain new and useful Improvements in Horse-Yokes, of which the following is a specification:

In the accompanying drawings, Figure 1 is a top view of my improvements in yokes. Fig. 2 is a transverse section of the same. Figs. 3 and 4 are bottom views, showing modified forms of the barbs.

My invention consists of a sheet-metal plate or brace of novel construction, with barbs and other devices, all of which will be fully understood by the following description:

The plate A is made of sheet metal, having lips B and C cut therein, as seen in Figs. 1 and 2. The barbs D, E, and F are inserted, as shown in Fig. 3. The flat barbs D, Fig. 3, are preferable on account of their keeping their place, if bent at the point, as seen in Fig. 2; but different forms of barbs may be used, the shank of the same being bent or clenched to hold them in place. The points are bent to fit different horses after the yoke has been tried on. The ends of the bow G are provided with several studs or nails, H, Fig. 2, in order to adjust the bow in the clasp-rings I to the size of the horse's neck. A wire lock, K, and key L secure the clasps I in place. A guard, M, is made of sheet metal. The ends thereof are curved or rounded, so as to slide back and forth without binding. The

guides N N are cut from the same piece with the guard M, and then bent over, so as to work on the wire O, which is inserted in holes in the ends, and the ends bent to hold the same in place.

A wire spring, S, pushes the guard forward, and thus covers the points of the barbs until the horse, by thrusting against the fence, pushes away the guard, and receives the barbs in his breast.

The above-described device is an improvement upon my horse-yoke patented November 30, 1875, my object being to make a cheaper and more durable horse-yoke.

Having thus described my invention, I claim—

1. The sheet-metal plate or brace A, having perforated lips B and C, in combination with the barbs, substantially as set forth.
2. The sheet-metal guard, having guides N N, in combination with the spring S and wire O, as specified.
3. The nails or studs H of the yoke or bow G, in combination with the spring-clasps I, substantially as and for the purposes set forth.

In testimony that I claim the foregoing as my own I affix my signature in presence of two witnesses.

JACOB BOYER.

Witnesses:

A. W. BEER,
A. REARICK.