



A. R. CRANDALL.

ENGINEERS' PLOTTING-TABLE.

No. 193,398.

Patented July 24, 1877.

Fig. 3

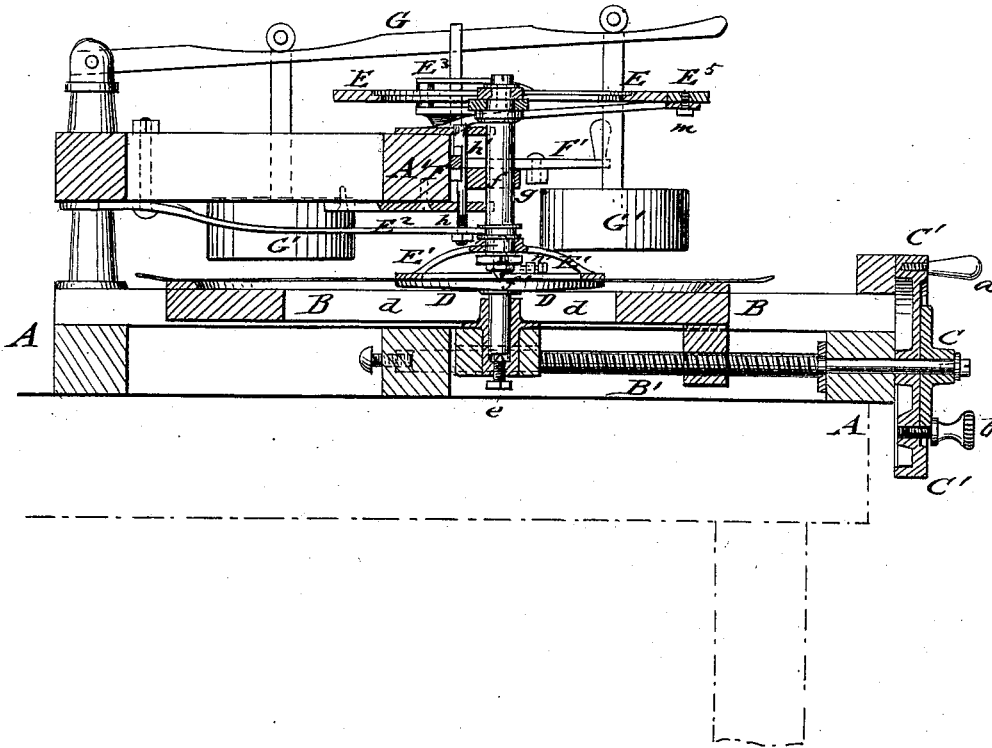

WITNESSES:

*C. Nereux*  
*J. H. Scarborough*

INVENTOR:

*A. R. Crandall*

BY

*Mumford*

ATTORNEYS.

# UNITED STATES PATENT OFFICE.

ALBERT R. CRANDALL, OF LEXINGTON, KENTUCKY.

## IMPROVEMENT IN ENGINEERS' PLOTTING-TABLES.

Specification forming part of Letters Patent No. 193,398, dated July 24, 1877; application filed June 18, 1877.

*To all whom it may concern:*

Be it known that I, ALBERT R. CRANDALL, of Lexington, in the county of Fayette and State of Kentucky, have invented a new and Improved Engineer's Plotting-Table, of which the following is a specification:

In the accompanying drawings, Figure 1 represents a front elevation, partly in section, Fig. 2 a plan view, and Fig. 3 a vertical longitudinal section on line *xx*, Fig. 2, of my improved engineer's and surveyor's plotting-table.

Similar letters of reference indicate corresponding parts.

The object of this invention is to furnish for engineers and surveyors an improved plotting-table, by which the field-notes may be plotted in rapid and accurate manner at a saving of time, and without taxing the eyes to injury in the least; and it consists of a sliding and slotted table carrying the plotting-paper, in connection with a base-disk and the foot or clamp of the protractor and retaining-weights. The foot or clamp and the protractor are arranged on a shaft vertically above the center of the base-disk, the shaft having a prick-point at the lower end for marking the stations.

A suitable lever arrangement raises, alternately, the weights from the paper, and lowers the foot-clamp of the protractor, or raises the foot-clamp and lowers the weights, which adjust themselves by pulleys on the concaved arms. The protractor turns the paper, and is adjusted by hand, and by a tangent-screw and spring-clamp, to the vernier. The foot-clamp carries a thread, adjustable by screws, in line with the zero-points of the protractor, to set the paper by, and to detect errors, in case any should occur.

The sliding table is operated by a micrometer-screw, whose head is divided at the circumference, being arranged to turn freely on the shank of the screw, and also to be clamped to a fixed head by a thumb-screw, so that each measurement may start from the zero-point of the head.

In the drawing, A represents a suitable supporting-frame, on which is moved, on accurate guides of wood or metal, a sliding table, B, which is operated by a micrometer-screw, B', having ten threads to the inch, or any other suitable division.

The end of the shank of the screw B' is provided with a rigid head, C, and with an axially-turning disk or head, C', that is made to turn loosely on the screw-shaft on being taken hold of by a handle, *a*, while it may also be clamped firmly to the fixed head C by a thumb-screw, *b*.

The circumference of the turning head C' is divided in one hundred divisions, and the head started from the zero-point, which registers with a mark of the table, so that each measurement may start from the zero-point, and be obtained by turning the head and screw for the required distance, which is thereby obtained on the sliding table.

The sliding table B is provided with a longitudinal slot, *d*, to move without obstruction along the shaft of a base-disk, D, which rotates freely in fixed bearings of frame A, and which is adjustable by a set-screw, *e*, below, so that its upper surface is in a plane with the surface of the table B.

Vertically above the base-disk, and in line with the axis of the same, is arranged a sliding shaft, *f*, to which a protractor, E, is secured to the upper end, while a foot or clamp, E<sup>1</sup>, of circular shape, is secured to the lower part of the shaft. The lower part of the shaft *f* is provided with a prick-point, *f'*, which registers accurately with the center of the base-disk D.

The size of the foot or clamp E<sup>1</sup> is equal to that of the base-disk, and presses on the plotting-paper introduced between clamp and disk.

The shaft of protractor and foot-clamp slides in a guide-bearing, *g*, of a supporting-piece, A', of frame A, giving thereby the clamp sufficient play either to be brought in contact with the paper, or to be raised from the same to allow it to move freely along under the clamp E<sup>1</sup>. When the clamp is brought down on the disk the paper may be turned to right or left by the protractor, and thereby the angles of the bearings set off with accuracy.

The foot or clamp E<sup>1</sup> is thrown down and clamped to the paper by a spring, E<sup>2</sup>, that bears into an annularly-grooved collar of the protractor-shaft.

A vertical rod, *h*, extends upward from the spring E<sup>2</sup>, and has a curved shoulder, *h'*, that is engaged by a horizontally-guided rod, F,

with raised step or shoulder  $h^2$ , the rod F being operated by a pivot-link,  $h^3$ , and swinging hand-lever F'. The guide-rod F raises or lowers the clamp E', according as the hand-lever F' is thrown to one side, until forming contact with supporting-piece A', or back until a shoulder of the rod F forms contact with a suitable stop,  $h^4$ , of the piece A'.

The sliding rod F is also connected, by pivot-rods  $i$ , with vertically-sliding rests  $i^1$ , which are guided in slotted upright standards  $i^2$ , the rests  $i^1$  bearing against the pivoted arms G of weights G', which hold the paper on the sliding table B.

The sliding rod F and hand-lever F' produce in this manner, alternately, the raising or lowering of the clamp and the lowering or raising of the weights, the paper being never free on the table, but held by the weights when the clamp is raised, and by the clamp when the weights are raised.

A spring-clamp, E<sup>3</sup>, binds on the protractor, and is operated by a tangent-screw, E<sup>4</sup>, so as not to require the clamping of the protractor with each reading of the vernier E<sup>5</sup>.

The vernier E<sup>5</sup> is supported on suitable arms extending from piece A', and secured by a set-screw,  $m$ , working in a slot of supporting-piece, and admitting the adjustment of the vernier to any desired fraction of a degree.

The arms G are concaved or inclined at the upper edge for the purpose of returning the weights G', which are hung thereto by arms with end pulleys, to a given position after each measurement. The weights are arranged at two diagonal corners of the paper, one in front and the other back of the supporting-piece A', as shown in the drawing; or four weights may be used.

The weights are interchangeable, and when the paper is to one side—right or left, back or front—the weights are so placed as to fall on the paper. A thread,  $n$ , is stretched across the foot or clamp E<sup>1</sup>, in line with the zero-points of the protractor. The thread is stretched over the grooved heads of adjustable screws  $n'$  of the clamp, and intended for the purpose of setting the paper thereby, and detect and correct any errors, if any should occur from carelessness or accident.

The plotting-table is used as follows: The hand-lever that controls the weights and protractor is turned to the left, so as to raise the weights and keep the paper tightly between clamp and disk with prick-point thereon. The protractor is then turned to the required reading, laying off the angle being used to adjust minutes of arc on the vernier. The hand-lever is then thrown to the right, and thereby the weights lowered and clamp raised. The distance is then laid off by bringing the head of the micrometer-screw to zero, clamping the same fast to the fixed head, and turning then the screw for the required distance. The hand-lever is then carried to the left again, and the clamp lowered, the prick-point mark-

ing the station. The next angle is then laid off by the protractor, then the next distance, and so on, the field-notes being thus plotted by taking the directions directly from the protractor without errors from size of prick-point or slipping of triangles, while the distances are laid off with almost absolute accuracy from station to station by the screw. The eyes are relieved from the strain of the old methods, and the amount of work per hour doubled, the apparatus forming thus a reliable and effective instrument for engineers' and surveyors' offices for the quick and accurate plotting of field-notes. The topography and details are then added and transferred to the final drawing by tracings, pantograph, or otherwise.

Having thus described my invention, I claim as new and desire to secure by Letters Patent—

1. A surveyor's or engineer's plotting-table, consisting of a sliding table, operated for laying down the distance by micrometer-screw, a revolving base-disk, a vertically-sliding protractor, with foot-clamp and prick-point, and paper-holding weights, substantially in the manner and for the purpose set forth.

2. The combination of the sliding and guiding table B with a micrometer-screw, B', having fixed head C, loosely turning, and graduated head C', and clamp-screw  $b$ , substantially as specified.

3. The combination of the sliding and guided table B, and revolving base-disk D, with alternately-applied foot-clamp E<sup>1</sup> of protractor, and paper-holding weights G', substantially as and for the purpose described.

4. The combination of the sliding and spring-pressed shaft  $f'$  of protractor and foot-clamp, and the pivoted and guided arms G of paper-holding weights G', with a suitable guide-rod and lever mechanism, for alternately raising foot-clamp and lowering weights, or lowering foot-clamp and raising weights, substantially as specified.

5. In an engineer's plotting-table, the combination, with the protractor E, of a spring-clamp, E<sup>3</sup>, and tangent-screw E<sup>4</sup>, to adjust protractor to vernier, substantially as set forth.

6. In an engineer's plotting-table, the combination of pivoted arms G, having concaved or inclined upper edges, with the weights G', suspended by arms with pulleys, for the purpose of returning weights to the required positions, substantially as described.

7. In an engineer's plotting-table, the combination, with the foot-clamp, of a diagonally-stretched thread, adjustable by set-screws, indicating zero-line of protractor, for the purpose set forth.

ALBERT ROGERS CRANDALL.

Witnesses:

TRUMAN SAUNDERS,  
HALDANE C. SAUNDERS.