

S. HENSHALL.

SOLE-EDGE BENDING-MACHINE.

No. 193,447.

Patented July 24, 1877.

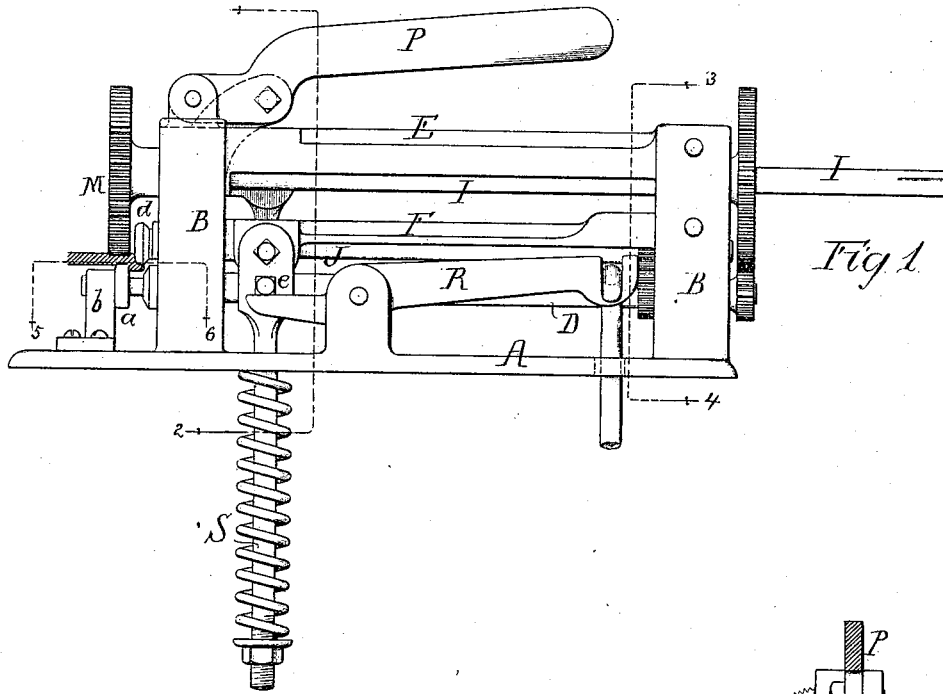

Fig 1

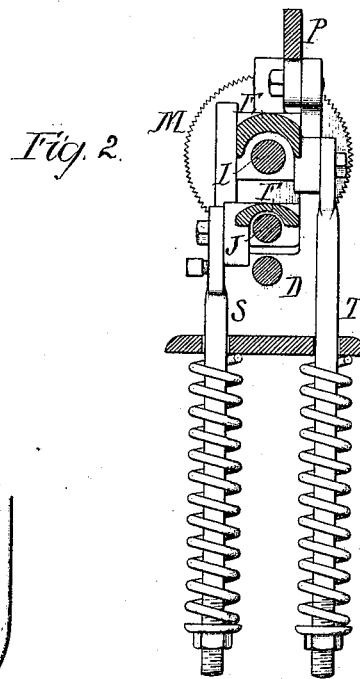

Fig. 2.

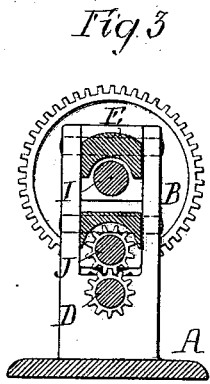

Fig 3

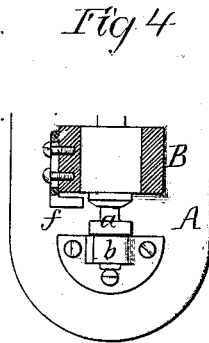

Fig 4

Witnesses
Henry Howson, Jr.
Henry Smith

Inventor
Samuel Henshall
by his Attorneys
Howson & Tom

UNITED STATES PATENT OFFICE.

SAMUEL HENSHALL, OF PHILADELPHIA, PENNSYLVANIA.

IMPROVEMENT IN SOLE-EDGE-BENDING MACHINES.

Specification forming part of Letters Patent No. **193,447**, dated July 24, 1877; application filed June 9, 1877.

To all whom it may concern:

Be it known that I, SAMUEL HENSHALL, of Philadelphia, Pennsylvania, have invented a new and useful Improvement in Edge-Turning Machines, of which the following is a specification:

My invention relates to an improvement in machines for turning down the edge of the sole of a boot or shoe after it has been channeled, the object of my invention being to so construct the machine that it will perform its work more effectually than the ordinary machines, an object attained in the following manner, reference being had to the accompanying drawing, in which—

Figure 1 is a side view of my improved edge-turner; Figs. 2 and 3, transverse sections on the lines 1 2 and 3 4, Fig. 1, respectively; and Fig. 4 a sectional plan on the line 5 6.

A is the base of the machine, near each end of which is a vertical standard, B, and in the latter, near the bottom, are formed bearings for a shaft, D, on the front end of which is formed a collar, *a*, the end of the shaft beyond this collar turning in a lug, *b*, on the base.

Hinged to the rear standard B of the machine are two frames, E and F, the outer ends of which slide in, and are guided by, the front standard, the former of these frames carrying a shaft, I, and the latter a shaft, J.

The shaft I is the driving-shaft, and carries at the front end a feed-wheel, M, while the shaft J carries a disk, *d*, occupying the vertical position shown in relation to the feed-wheel.

The shafts D, I, and J are so geared together that the peripheries of the collar *a*, feed-wheel M, and disk *d* move at the same speed.

The vertical position of the feed-wheel M can be varied by operating a lever, P, hung to the frame of the machine, and having a short arm connected to the front end of the hinged frame E, and the vertical position of the disk *d* can also be changed at pleasure by operating a lever, R, the long arm of which is connected to a suitable treadle, while the short arm acts upon a pin, *e*, carried by a rod, S, secured to the frame F.

The rod S extends down through the base, and is acted upon by a spring, which tends

to constantly depress the same, a similar spring-rod, T, being attached to the frame E.

In operating on a sole the levers P and R are first moved so as to raise the feed-wheel M and disk *d*. The sole is then inserted between the wheel M and collar *a* to such an extent that its outer edge is just beneath the disk *d*, the proper position being determined by a stop, *f*, Fig 4.

The feed-wheel is then allowed to descend, so as to clamp the sole firmly between its edge and that of the collar *a*, and the disk *d* finally descends so as to bend down the edge between it and the said collar *a*.

The turning of the feed-wheel causes the passage of the sole through the machine and the consequent bending down of the edge of the same, and this is continued until the entire edge of the sole has been operated upon, when the feed-wheel M and disk *d* are raised, the sole removed, and a new one inserted.

It will be seen that the disk *d* is, in its vertical movement, entirely independent of the feed-wheel M, so that inequalities in the thickness of the sole, which cause irregular vertical movement of said feed-wheel, cannot thereby affect the operation of the disk *d*. I am thus enabled to effect the turning down of the edge regularly around the entire sole, thereby overcoming a serious objection to the ordinary edge-turning machines, in which the turning-disk *d* is carried by the same shaft as the feed-wheel.

I claim as my invention—

1. The combination, in a sole-edge bending machine, of a feed-wheel, an edge-turning disk, and a stock-supporting collar, the said wheel and disk being provided with means for independent vertical adjustment, substantially as set forth.

2. The combination of the fixed shaft D and its collar *a* with the feed-wheel M and turning-disk *d*, the shafts of which are carried by pivoted spring-frames E and F, as specified.

In testimony whereof I have signed my name to this specification in the presence of two subscribing witnesses.

SAMUEL HENSHALL.

Witnesses:

HERMANN MOESSNER,
HARRY SMITH.