

I. D. CROSS.  
FIRE-ESCAPE.

No. 193,489.

Patented July 24, 1877.

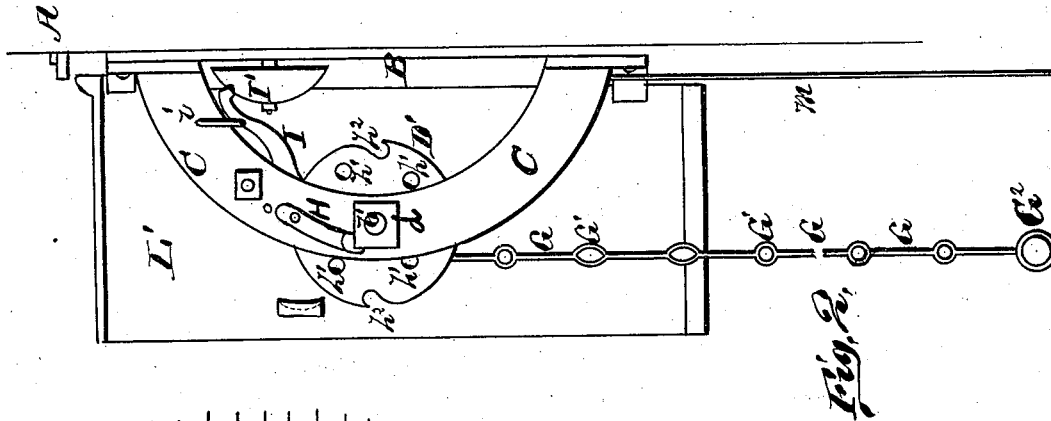

*Fig. 2.*

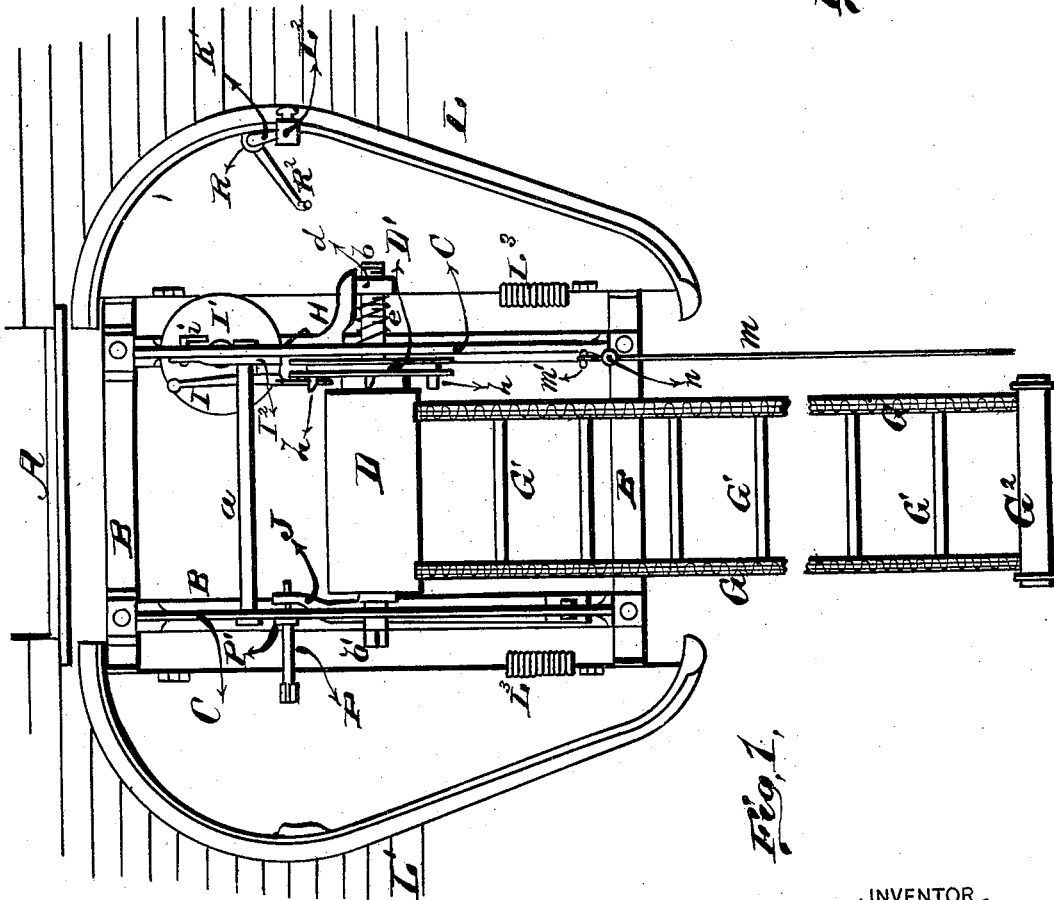

*Fig. 1.*

WITNESSES

*Wm. H. Bates*  
*George C. Upham*

INVENTOR.

*Ira D. Cross.*  
*Giuseppe Smith*

ATTORNEYS.

I. D. CROSS.  
FIRE-ESCAPE.

No. 193,489.

Patented July 24, 1877.

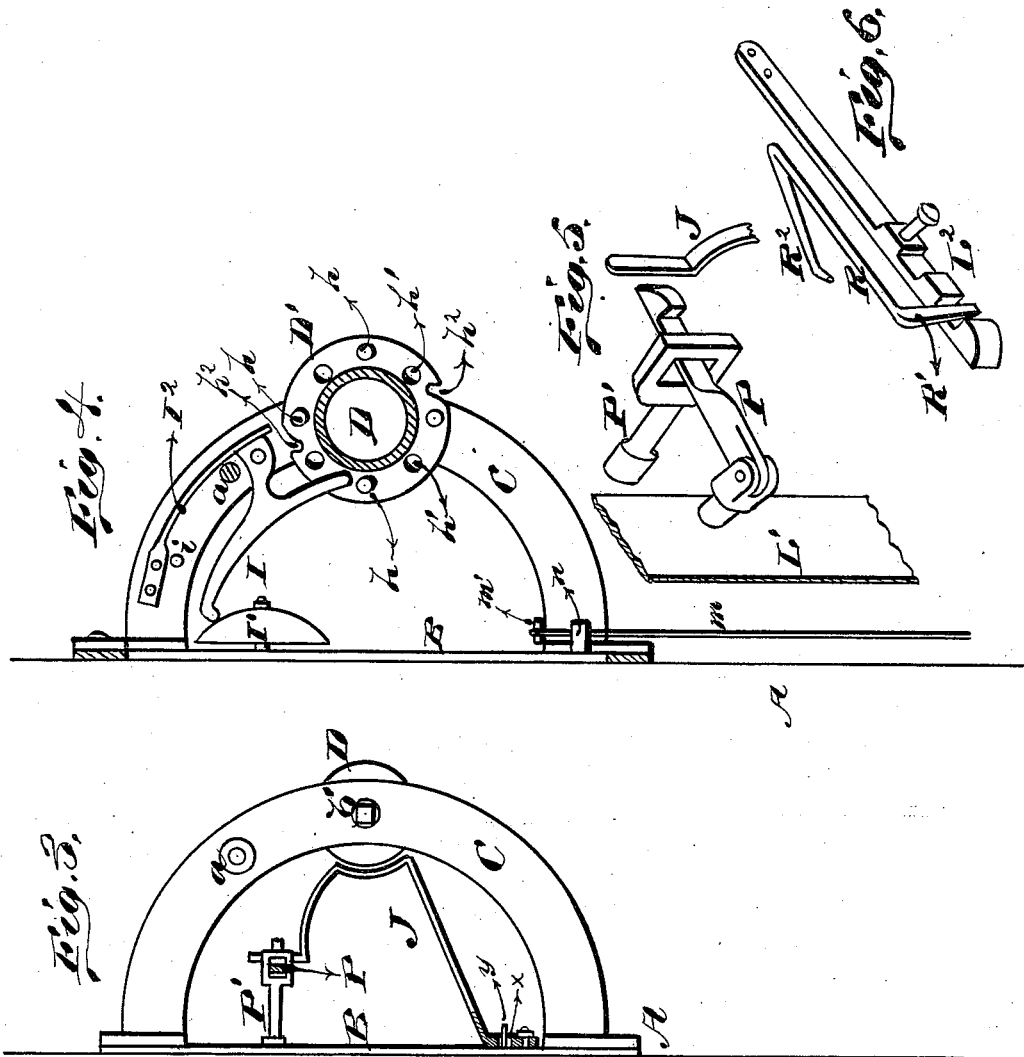

WITNESSES  
*E. Bates*  
*George E. Upshaw*

INVENTOR.  
*Ira D. Cross*  
*Jelmore Smith & Co.*  
ATTORNEYS.

I. D. CROSS.  
FIRE-ESCAPE.

No. 193,489.

Patented July 24, 1877.

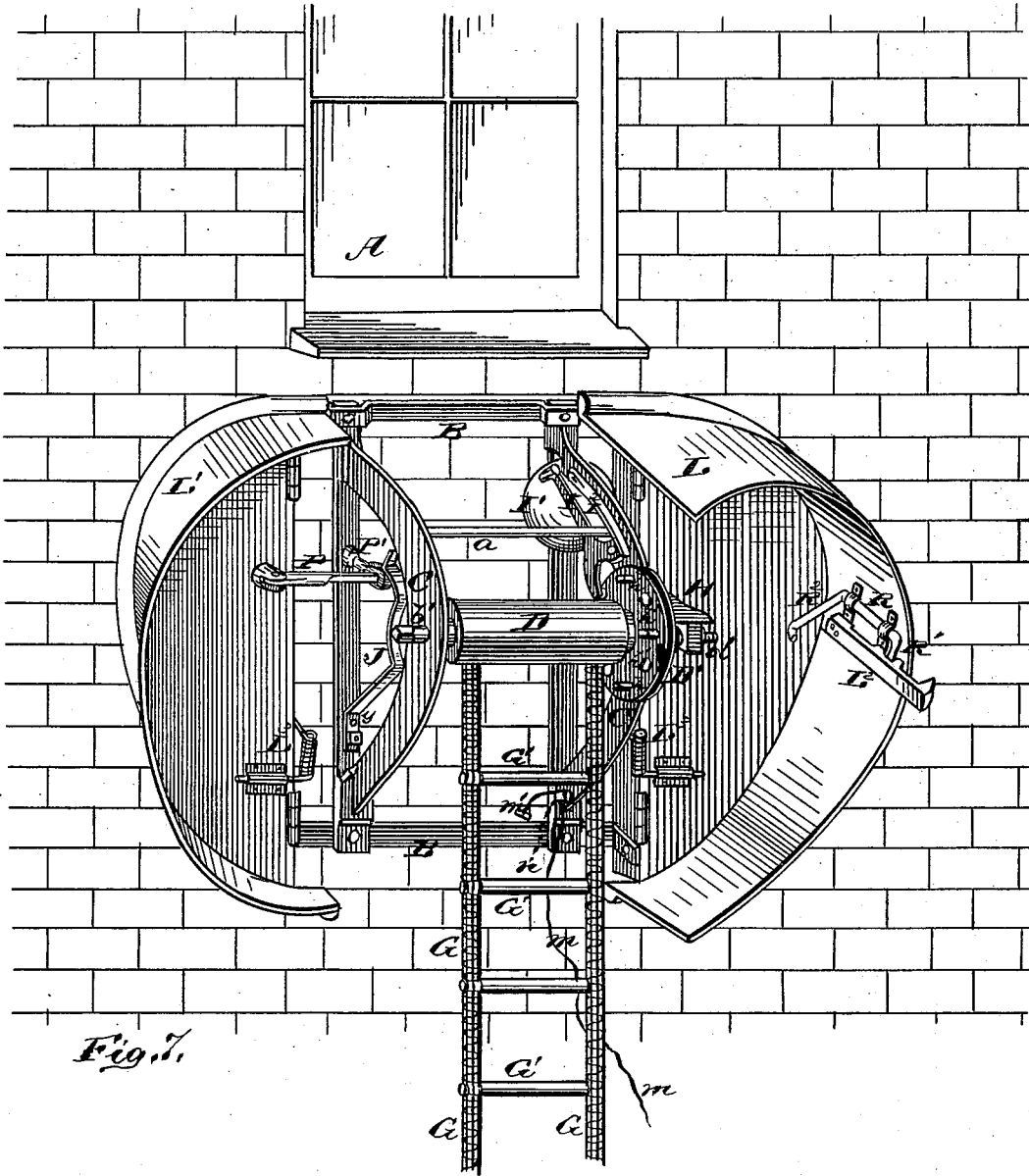

Fig. 1.

WITNESSES  
*E. H. Bates*  
*Robert Everett*

INVENTOR.  
*I. D. Cross.*  
*Gilmore, Smith & Co.*  
ATTORNEYS.

# UNITED STATES PATENT OFFICE.

IRA D. CROSS, OF RENO, NEVADA.

## IMPROVEMENT IN FIRE-ESCAPES.

Specification forming part of Letters Patent No. 193,489, dated July 24, 1877; application filed May 19, 1877.

*To all whom it may concern :*

Be it known that I, IRA D. CROSS, of Reno, in the county of Washoe and State of Nevada, have invented a new and valuable Improvement in Fire-Escapes; and I do hereby declare that the following is a full, clear, and exact description of the construction and operation of the same, reference being had to the annexed drawings, making a part of this specification, and to the letters and figures of reference marked thereon.

Figure 1 of the drawings is a representation of a front view of my fire-escape as applied. Figs. 2 and 3 are side views. Fig. 4 is a vertical sectional view, and Figs. 5 and 6 are perspective details, of the same. Fig. 7 is a perspective view of my invention.

The nature of my invention consists in the construction and arrangement of a fire-escape composed of a safety-ladder and an alarm, as will be hereinafter more fully set forth.

The annexed drawings, to which reference is made, fully illustrate my invention.

A represents the front of a dwelling-house or other building, to which my fire-escape is attached. B is a metallic frame, permanently attached to the wall A, and provided with two side arches, C C, connected near the top by a rod, *a*, and also forming journal-bearings for a drum, D, to which the ladder is attached. This ladder consists of two strongly-woven wire stretchers, G G, connected by metallic rounds or cross-bars G<sup>1</sup> G<sup>1</sup> of oval or other suitable form. At the bottom of the ladder is attached a very heavy cross-bar, G<sup>2</sup>. *b b'* are the journals of the drum D, as shown. The journal *b'* is constructed to receive on its end a crank, by means of which the drum may be rotated to roll up the ladder. The other journal, *b*, is extended a suitable distance beyond the arch C on that side, and is formed with screw-threads to receive a nut, *d*, and between this nut and the arch is a spiral spring, *e*, surrounding the journal. To this arch C is pivoted an arm, H, the end of which is flanged, to rest on and hold the nut *d* from rotating. At this end of the drum D, inside of the arch, is formed or attached a circumferentially-grooved wheel or disk, D', provided on its inner side with a series of inwardly-projecting pins, *h h*. This disk or wheel has also a series

of slots, *h'*, through it, and on its edge are two or more hook-shaped notches, *h''*, as shown.

The pins *h* are intended to operate a bell-hammer, I, for striking and sounding an alarm-bell, I<sup>1</sup>. I<sup>2</sup> is a spring for actuating the bell-hammer I.

On the other side of the apparatus is a spring-brake, J, pivoted to the frame B, and intended to operate against the periphery of the drum D at that end. The movement of the brake J on its pivot is limited by a pin, *y*, projecting from the frame B through a slot, *x*, in the brake, near its pivoted end.

The entire apparatus, when the ladder is rolled up on the drum, is inclosed within a casing composed of two parts, L L', hinged one on each side of the frame B, and meeting in the center, with a spring-catch, L<sup>2</sup>, for holding them closed. The casings L L' are further, at their hinges, provided with springs L<sup>3</sup>, arranged in such a manner that as soon as the spring-catch L<sup>2</sup> is released said springs L<sup>3</sup> will instantaneously throw the casings outward away from the apparatus.

On the inside of the casing L, in suitable bearings, is placed a shaft, R, having at one end an arm, R<sup>1</sup>, to operate against the spring-catch, L<sup>2</sup>, and at the other end said shaft has a crank-arm, R<sup>2</sup>, as shown. The other casing, L', is provided with a hinged spring-catch, P, which passes through a slotted stud, P', projecting from the frame B, and is intended to operate against the spring-brake J, as herein-after described.

Supposing that the casings L L' are open, and the ladder run down; then, before winding up the ladder, raise the bell-hammer I sufficiently high to slip a bolt, *i*, in the arch on that side under it. Then raise the flanged arm or brace H clear up out of the way, and run the nut *d* nearly out to the end of the journal *b*. Turn the crank toward the inside, winding up the ladder toward the inside of the drum until the bottom round G<sup>2</sup> of the ladder is about midway between the drum and the lower part of the casings or covers. The brake J is then turned onto the edge of the drum, which, by friction, will hold the ladder from running down.

*m* is a wire or cord, passed through an eyebolt, *n*, near the lower end of the frame B, and

has a pin,  $m'$ , attached to its upper end. This wire or cord is drawn up on the inside of the wheel  $D'$ , and passed between the bell-lever and arch in the groove of said wheel, and the pin placed in one of the notches  $h^2$ . The bell-hammer  $I$  is then let down on the bell  $P$ , and the brace  $H$  turned down on the nut  $d$ . The casing or cover  $L$  is first turned carefully inward, until by turning the drum a little either way the end of the crank  $R^2$  can enter one of the holes or slots  $h^1$  in the wheel  $D'$ . This cover is now held perfectly shut, and then the other cover,  $L^1$ , is brought inward and the two shut close and tight together, and held by the spring-catch  $L^2$ .

The wire or cord  $m$ , above mentioned, is to pass through other eyebolts on the side of the window-frame, on the outside, as far down as desired. By pulling on this wire or cord the wheel  $D'$  will be turned, which, by means of the crank  $R^2$ , turns the shaft  $R$  so that the arm  $R^1$  will release the spring-catch  $L^2$ , and the covers spring open. The cover  $L^1$ , in flying open, will, by means of the spring-catch  $P$ , draw the friction-brake  $J$  off from the drum. This will liberate the ladder, which will run down immediately, and at the same time ring the fire-alarm by the pins  $h$  in succession operating the bell-hammer  $I$ .

A person in the window above where the machine is fastened can run the ladder down and sound the alarm by simply pressing a knob on the outside of the covers, said knob projecting from the catch  $L^2$ .

Of course the crank used in winding up the ladder will have to be taken off before the last cover is closed, and is to be kept in a suitable place to be used when required.

It will be noticed that, as the ladder runs down, the arm or brace  $H$  will prevent the nut  $d$  from turning, which nut will therefore run toward the frame and press the spiral spring  $e$ . This will cause the wheel  $D'$  to rub against the arch  $C$ , thus acting as a brake, preventing the ladder from stopping with a sudden jerk, which might in time injure the machine.

The nut  $d$ , by being placed at the proper distance from the end of the journal, can be made to operate on any length of ladder.

The bottom round  $G^2$  of the ladder is made heavier than the others, for the purpose of starting the ladder running down easily, and also for holding the ladder steadier when it is down.

These machines are intended to be put up as close under the window-sills as they can be placed, so that a person in the upper window can easily reach the knob for opening the covers, and so that a person can climb over the machine to the ladder.

These machines, being always ready and capable of being operated instantly, will afford ample and safe egress from the several stories of burning buildings; and in case the fire breaks out of either of the windows below where the machine is attached, the ladder can be swung to either side or away from the building by a person on the ground without danger or injury to the machine or persons going up or down. It not only affords egress to people in the building, but will be found of great value to firemen extinguishing fire, for when the alarm is heard it not only awakens the inmates immediately, but also informs the neighborhood that there is a fire in the building.

What I claim as new, and desire to secure by Letters Patent, is—

1. The spring-cover  $L^1$ , with hinged spring-catch  $P$ , in combination with the brake  $J$ , for the purposes set forth.

2. The combination of the grooved wheel  $D'$ , having slots  $h^1$  and notches  $h^2$ , the cord or wire  $m$ , with pin  $m'$ , the spring-cover  $L$ , shaft  $R$ , with arm  $R^1$  and crank  $R^2$ , and the spring-catch  $L^2$ , all substantially as and for the purpose set forth.

3. The combination of the arches  $C$ , drum  $D$ , with threaded journal  $b$ , nut  $d$ , spring  $e$ , and arm or brace  $H$ , substantially as and for the purpose set forth.

In testimony that I claim the above I have hereunto subscribed my name in the presence of two witnesses.

IRA DAVIS CROSS.

Witnesses:

CHARLES T. BENDER,  
JAMES H. BORLAND.