

J. KEATS.

MACHINE FOR CHANNELING THE SOLES OF BOOTS AND SHOES.
No. 193,517.

Patented July 24, 1877.

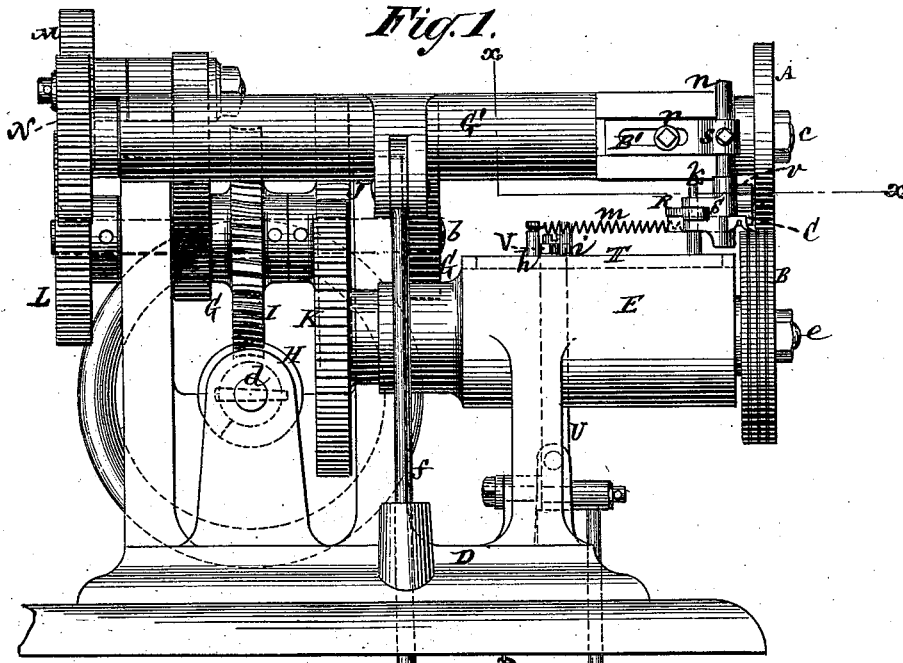
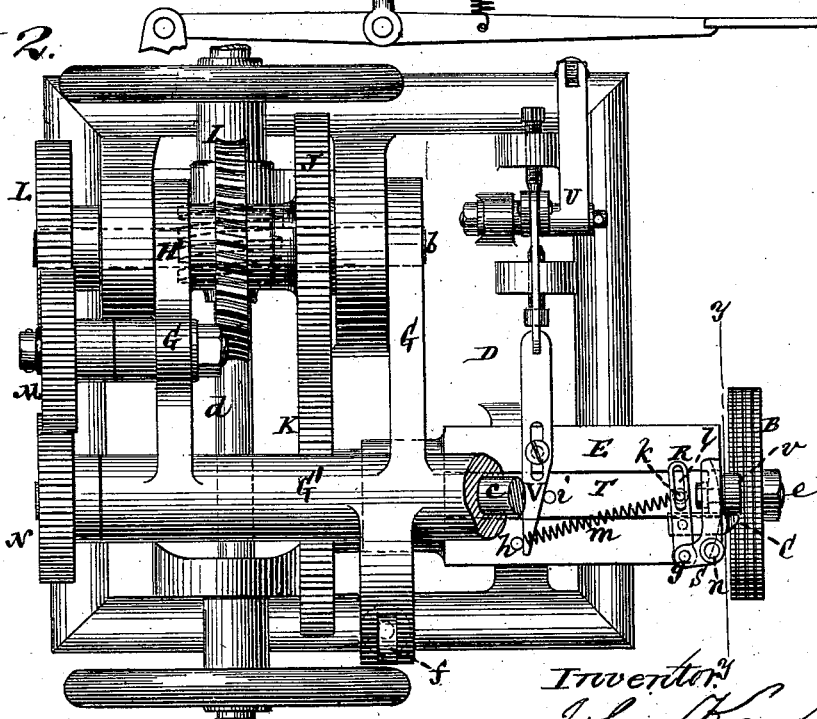

Fig. 2.



Witnesses
 John Becker.
 Fred Raynes

Inventor
 John Keats
 by his Attorneys
 Brown & Allen

J. KEATS.

MACHINE FOR CHANNELING THE SOLES OF BOOTS AND SHOES.
No. 193,517.

Patented July 24, 1877.

Fig. 3.

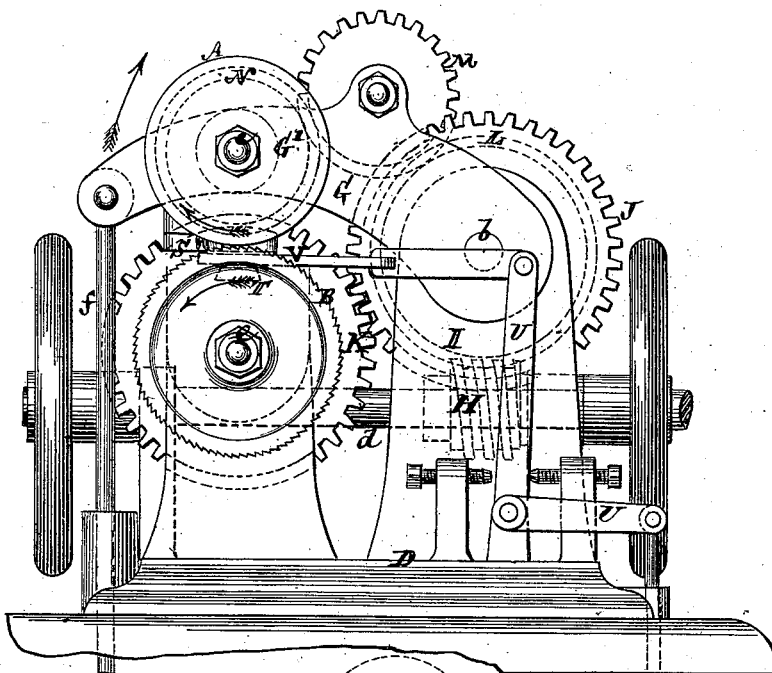
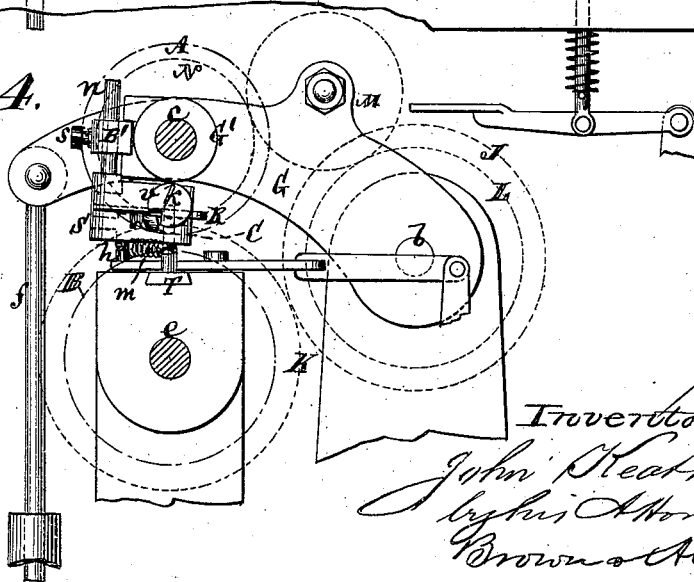

Fig. 4.



Witnesses
John Becker
Fred Haynes

Inventor:
John Keats
by his Attorneys
Brown & Allen

UNITED STATES PATENT OFFICE.

JOHN KEATS, OF WOOD GREEN, ENGLAND.

IMPROVEMENT IN MACHINES FOR CHANNELING THE SOLES OF BOOTS AND SHOES.

Specification forming part of Letters Patent No. 198,517, dated July 24, 1877; application filed June 13, 1877.

To all whom it may concern:

Be it known that I, JOHN KEATS, of Wood Green, in the county of Middlesex, England, have invented certain new and useful Improvements in Machines for Channeling and Preparing the Soles, Insoles, and Welts of Boots and Shoes, of which the following is a description, reference being had to the accompanying drawing, forming part of this specification.

This invention has for its object the chamfering, channeling, beveling, and preparing the soles and welts of boots and shoes, for their attachment to the uppers by sewing, but will here be more particularly described with reference to the channeling of the sole to receive the stitching, which latter may be done by any suitable sewing-machine. The same mechanism, however, by a suitable change of the knife which effects the cut, may be used for the other operations above referred to, although to facilitate manufacture it is preferred to use a separate machine for each of said operations.

The invention consists in certain novel constructions and combinations of the knife-adjusting, controlling, and guiding devices, whereby increased facility is afforded for determining or varying the cut in the work.

Figure 1 represents a side view of a machine having my invention applied; Fig. 2, a plan of the same, with a certain upper front portion removed as indicated by the line X X. Fig. 3 is a front elevation thereof; and Fig. 4, a partially sectional front view, taken as indicated by the line *y y*.

Prior to introducing the sole to be channeled to the machine shown in the drawing, it is cut or stamped out to its required facial contour, and, if necessary, otherwise suitably prepared, as customary in working the channeling-machines, in which, as in the present machine, the sole is introduced between upper and lower feeding-wheels, and in the course of its passage between said wheels, is subjected to the action of an inclined knife which cuts the channel in the grain side of the leather to receive the stitching, the sole being suitably directed and guided at its edge during said operation to space the cut as required relatively to said edge.

A and B are upper and lower feed-wheels, which may be of different diameters, but should have a uniform surface velocity on their peripheries. The lower one, B, of these wheels, which supports the sole, may be of serrated construction on its feeding-surface, while the upper wheel, A, which acts upon the grain side of the leather, is smooth.

In other operations, when the grain side of the leather is undermost, then the relative position of these smooth and roughened feed-wheels may be reversed.

C is the inclined knife which cuts the channel in the sole to provide for the subsequent sewing of the latter with the other parts of the boot or shoe.

D is the base of the main frame, on which are mounted standards or uprights for support of the driving mechanism and other working parts.

The lower feed-wheel B has a fixed axis of rotation in a stationary arm, E, but the upper feed-wheel A is carried by a hinged or pivoted frame which has its center of motion *b* to one side of the axis of the lower wheel B, in parallel relation with said axis. This laterally-pivoted frame, which provides for the up-and-down adjustment of the upper feed-wheel A relatively to the lower feed-wheel B, is composed mainly of side arms G G, free to rock on the shaft *b* as a center of motion, and a connecting and extended sleeve or hollow bearing, G', on the outer ends of said arms, for the shaft *c* of the upper feed-wheel A to rotate in.

Motion is communicated to the feed-wheels A and B as follows: Power is transmitted, by means of belt and pulleys, or otherwise, to a main driving-shaft, *d*, at the back of the machine, in parallel relation with the feed. On this shaft is an endless screw, H, which serves to give motion to a worm-wheel, I, on the shaft *b*, about which the rocking frame G G' works. Said shaft *b* carries a spur-wheel, J, which gears with a wheel, K, on the shaft *c* of the lower feed-wheel B, to give a rotary feeding motion to the latter. The shaft *b* also carries on its rear end a spur wheel or pinion, L, which gives motion, through an intermediate wheel, M, to a wheel, N, on the shaft *c* of the upper wheel A, to actuate the latter, said wheels M

and N both being carried by the rocking frame G G', and having their axes in one and the same concentric relation with the stationary axis *b* of the driving mechanism. By this combination of feed-wheel driving mechanism with the laterally-pivoted rocking frame carrying one of the feed-wheels and the gears by which the motion is communicated to the latter, not only is a smooth, steady, and powerful feed-motion obtained, with facility for opening and closing the feeding devices to enter and remove the work, subject to a parallel adjustment of the feeding-surfaces in a crosswise direction, but a continuous motion of both feed-wheels is kept up during all adjustments of the one wheel relatively to the other, and said wheels are made to readily adapt themselves to different thicknesses of work, or to irregularities in the latter, without interfering with or stopping the feed. A treadle-motion, under control of the operator, may be connected, by a rod, *j*, with the rocking frame G G', to keep the wheel A down on the work as against the pressure of a spring which lifts said frame.

The knife C is adjusted and controlled, to determine or vary its cut in the work passing through or in between the feed-wheels A B, as follows: Said knife is attached to a slotted lever, R, which has its fulcrum *g* on or over the off side of the axis of the feeding-wheels, within a bracket, S, which is constructed to form a fence, guard, or guide for the edge of the sole at the back of the feeding-wheel B. The stock of the knife C is fitted to slide in and out through this bracket S by means of the lever R, which has its position controlled by a slide, T, in and along the stationary arm E. This gives to the knife a variable adjustment in a transverse direction to the feed, to regulate the extent of the knife's entry into the sole relatively to that edge of the latter which bears against the fence formed by the bracket S. Such variable adjustment is controlled by the operator—as, for instance, by a treadle or otherwise, through a bell-crank, U, which has attached to it a sliding inclined bar or wedge, V, that is arranged to move in a transverse relation across the stationary arm E, and bears at its back against a stop or guide pin, *h*, on said arm, and is in contact on its inclined face with a stud, *i*, on the longitudinal slide T within the arm E. This slide T has mounted on or near its forward end an elongated pin or stud, *k*, which enters up within a slot, *l*, in the lever R, and is furthermore connected, by a spring, *m*, with the stop or guide pin *h*. Pressure applied by the operator to the bell-crank U serves to project forward the knife C, as against the tension of the spring *m*, which draws it back.

Besides this variable adjustment of the knife C, it has two positive adjustments, which serve to give to it a universality of action or general adaptability to different kinds of work and different depths of cut. Thus the bracket

S is adjustable in or out relatively to the feed by means of an adjustable slide, B', with which the bracket S is connected by an upright end shank, *n*, that is adjustable up and down within a socket in the front end of the slide B'. These positive adjustments, which may be secured by set-screws *r s*, provide alike for the adaptation of the cutter to various thicknesses of work, likewise determine its depth or extent of entry, and general distance of the cut from the edge of the work. None of these adjustments are interfered with by the rocking or adjustment of the frame G G', to adapt the adjustable feeding-wheel to different thicknesses of work, or to varying irregularities in the work; and as the rocking frame which carries the cutter and the upper feed-wheel swings on an axis parallel with the axes of the feed-wheels, the inclination of the knife in a direction transverse to the sole is not varied by the rising and falling of said frame to suit different thicknesses of sole. In advance of the knife, and carried by the bracket S, is a pressing roller or guide, *v*, beneath which the leather is passed to be cut, and which bears down on the edge of the work to hold it to the cut, also assists in preserving a uniformity in the depth of the cut by the knife.

What I claim as my invention is—

1. The combination, with the rocking frame G, moving about an axis parallel with the axes of the feed-wheels, of a cutter-carrying and guide bracket or piece, S, having both an upward and downward and a horizontal adjustment relatively to said rocking frame, and a knife having a horizontal adjustment, not only with reference to the said rocking frame, but also with reference to said bracket, substantially as herein shown and described, for the purpose set forth.

2. The combination, with the rocking frame which carries the upper feed-wheels of a machine for channeling or preparing the soles of boots and shoes, of the slide B', adjustable in said frame, the knife-carrying and guiding bracket S, adjustable in said slide, the knife C, sliding freely through said bracket, and mechanism connected with said bracket, for varying the position of said knife relatively to the guiding-face of said bracket, substantially as herein described.

3. The combination, with the frame G, rocking on an axis parallel with the axes of the feed-wheels, and the cutter-carrying and guide bracket S, attached to said frame G, of the knife C, sliding through said bracket, the lever R, attached to said bracket and connected with said knife, and the slide T and pin K, connected with said lever R, substantially as and for the purpose herein set forth.

JOHN KEATS.

Witnesses:

HENRY T. BROWN,
MICHAEL RYAN.