

J. H. LEWARS & C. KLAITZ.
SAFETY-VALVE FOR LAMPS.

No. 193,525.

Patented July 24, 1877.

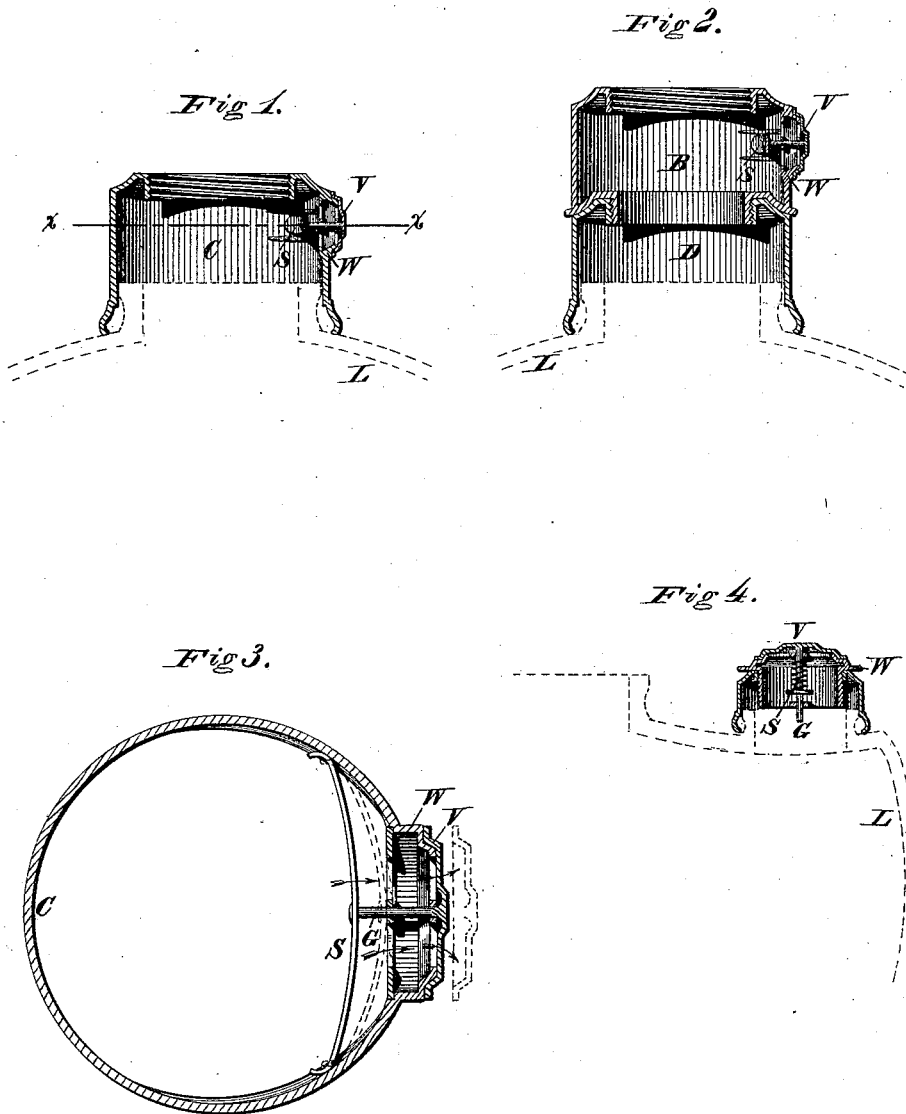

Witnesses.

Harry King
Det.
D. P. Low

Inventors

Lewars & Klaitz
By their Attorneys
Stansbury & Lullum

UNITED STATES PATENT OFFICE.

JOHN H. LEWARS AND CHARLES KLAITZ, OF PHILADELPHIA, PA.,
ASSIGNORS TO WILLIAM E. S. BAKER, OF SAME PLACE.

IMPROVEMENT IN SAFETY-VALVES FOR LAMPS.

Specification forming part of Letters Patent No. **193,525**, dated July 24, 1877; application filed June 22, 1877.

To all whom it may concern:

Be it known that we, JOHN H. LEWARS and CHARLES KLAITZ, both of Philadelphia, in the State of Pennsylvania, have invented certain Improvements in Safety-Collars for Lamps for Burning Explosive Oils, of which the following is a correct specification, reference being had to the accompanying drawings, in which—

Figure 1 is a central vertical section of our improved lamp-collar, applied directly to the body of the lamp, which is shown by dotted lines. Fig. 2 is a similar section of a supplemental collar provided with our improvements, and screwed onto the top of the ordinary fixed collar of a lamp. Fig. 3 is a horizontal section, on an enlarged scale, of our improved collar, taken on line *xx* of Fig. 1. Fig. 4 shows our improved valve applied to the oil-feeder of a lamp.

The same letter indicates the same part in all the figures.

The nature of our invention consists in an improvement in the safety-valve of a lamp for burning explosive oils, and the mode of attaching the same, by which the valve is held securely to its seat, is rendered gas and air tight when closed, and yet acts readily to relieve pressure in case of an explosion of gas within the lamp.

Our experiments with devices for relieving explosions in lamps have convinced us that in order to attain perfect safety it is necessary to have the valve gas and air tight, and to provide for its prompt opening and perfect closure after it has acted, and allow the harmless escape of the explosive gases. This is not the case with the flat valves ordinarily employed, as there is not perfect contact between the valve and its seat without packing, which is liable to become displaced while acting, and the long flat springs are apt to take a "set" from the force of an explosion, and leave the valve only partially closed.

To obviate these difficulties we strike the valve and valve-seat with corresponding dies, so that the valve shall, when closed, exactly fit upon and come into close metallic contact

with the seat, and, without packing, be gas-tight.

We attach the valve to a guiding-spindle, which preserves it at all times in proper relations to the seat, and we draw the valve to its seat by means of a bow or other spring placed within the collar. We prefer to make the valve and seat circular, that they may meet and fit in all positions without adjustment. The spring, being placed within the collar, is protected from injury from without.

In the drawings, C marks the safety-collar, which, in Fig. 1, is represented as fixed to the body of the lamp L. W is the valve-seat, which is struck up in a die, and has, preferably, the conoidal shape shown. V is the valve, struck from a die corresponding in shape and size to that used for producing the seat, so that the under side of the valve shall exactly receive and cover the conoidal projection of the seat. The valve is attached to the guide G, which works through one or more supporting-bars, and is attached, at its inner end, to a bow-spring, S, the reaction of which tends to draw the valve into contact with its seat.

In Fig. 2 is represented a modification of the arrangement shown in Fig. 1, the fixed collar D, having the usual construction, and the supplemental collar B, provided with our improvements, being screwed onto it, as clearly represented in the figure.

Fig. 4 illustrates the application of the improved valve to a lamp oil-feeder, attached to the body of a lamp, L, in the usual way. In this arrangement the guide-rod G is surrounded by a spiral spring, which reacts against a plate on the guide G, to bring the valve down to its seat. The collar, in this case, is tapped and the valve-seat threaded, so that it can be unscrewed when the feeder is to be opened for the reception of oil. A bow-spring would, in such a case, be in the way, and hence we replace it by the more convenient form.

We contemplate the application of the same kind of a cap and valve to oil-cans for the same purpose.

What we claim, and desire to secure by Letters Patent, is—

The combination, with the fixed or supplemental collar of a lamp, of a valve and valve-seat, struck up in corresponding dies, as described, and provided with the guide G and springs S, all constructed, arranged, and operating as set forth.

The above specification of our said invention signed and witnessed, at Philadelphia, this 8th day of June, A. D. 1877.

JOHN H. LEWARS.
CHARLES KLAITZ.

Witnesses:

GUSTAV GOEBEL,
A. SCHOHAY.