

H. M. BRADLEY.
 COMBINED TUBE-CLAMP AND WRENCH FOR SUSTAINING THE
 LINING OF ARTESIAN WELLS.

No. 193,595.

Patented July 31, 1877.

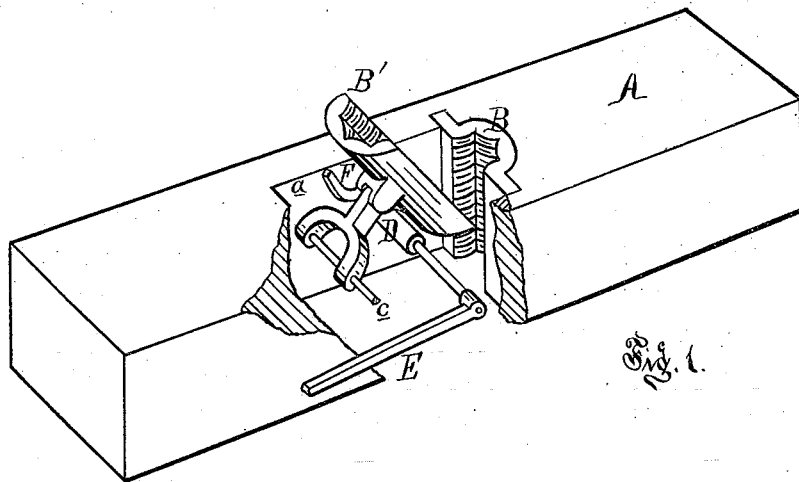

Fig. 1.

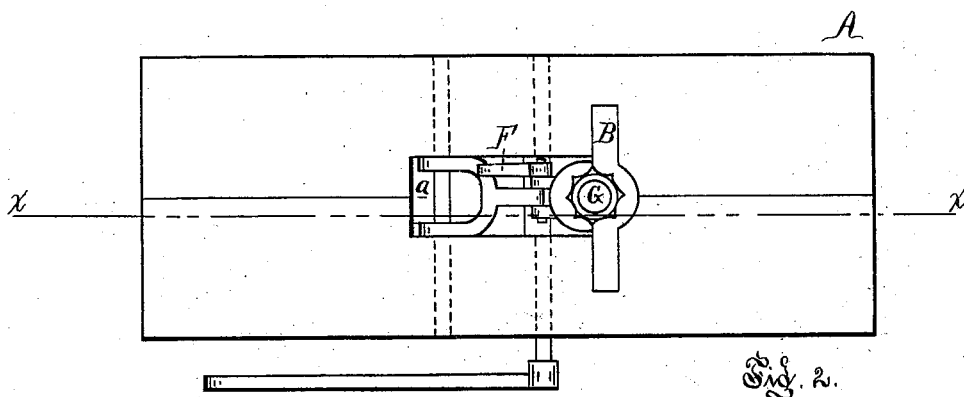

Fig. 2.

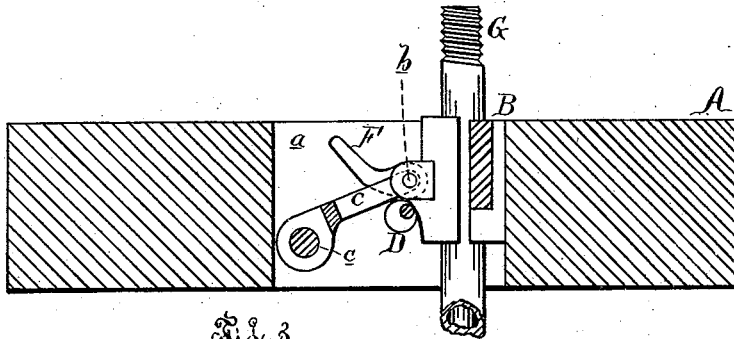

Fig. 3.

Attest:
 H. L. Cullis
 Chas. J. Hunt

Inventor:
 H. M. Bradley
 By atty
 Wm. S. Sprague

UNITED STATES PATENT OFFICE.

HENRY M. BRADLEY, OF BAY CITY, MICHIGAN.

IMPROVEMENT IN COMBINED TUBE-CLAMP AND WRENCH FOR SUSTAINING THE LINING OF ARTESIAN WELLS.

Specification forming part of Letters Patent No. **193,595**, dated July 31, 1877; application filed April 4, 1877.

To all whom it may concern:

Be it known that I, HENRY M. BRADLEY, of Bay City, in the county of Bay and State of Michigan, have invented a new and useful Combined Tube-Clamp and Wrench, of which the following is a specification:

The object I have in view is to provide a device for sustaining the lining-tubes of Artesian wells in case the hoisting apparatus should give way, and thus to prevent the tube from falling back into the well, and also to serve as a wrench for screwing and unscrewing the sections of tubing as they come to the surface.

Figure 1 is a perspective view. Fig. 2 is a plan or top view. Fig. 3 is a longitudinal section at *xx*, Fig. 2.

In the drawing, A represents a handle or wrench, preferably made of two bars of wood bolted together side by side. In the middle there is a mortise, *a*, in one end of which a semicircular jaw, B, is secured by letting its side ribs into the timbers. B' is a loose or movable corresponding jaw, having a pair of lugs on its outer side, between which is pivoted, by a pin, *b*, the end of a lever, C, the other end of which is forked, and pivoted to a bolt, *c*, transversely inserted in the wrench at the other end of the slot. The length of the lever C is such that the jaw B' will be carried into contact with the jaw B before said lever drops to the horizontal plane.

The jaws are adapted to grasp the well-tube G, and are serrated vertically to prevent slipping around on it. Lying across the mouth of the well, the device would offer no impediment to the lifting of the tubing between the jaws; but if the tubing should slip by reason of the breaking of the hoisting-gear, or from any other cause, the loose jaw B' would immediately wedge it fast, and thus prevent it from falling down the well.

To tighten the jaws upon the pipe, so that the device can be used as a wrench to screw

or unscrew the joints, a shaft provided with an eccentric, D, is transversely journaled across the slot outside the jaw B', and below its lugs, with a lever, E, on the outer end. By throwing up this lever E, the eccentric, bearing against the jaw B', forces the latter toward the stationary jaw, the pipe G being gripped between the two with great force.

On the pivot-pin *b* is hung a dog, F, outside of one of the lugs of the jaw B'. When such dog is thrown down before throwing up the lever E, the jaw B' will be released from the pipe by the eccentric raising the heel of said dog.

Before the lever is raised to clamp the tube, the dog must be thrown up out of the reach of the eccentric.

What I claim as my invention is—

1. The combination, with the bar A, of the stationary semicircular jaw B, set into the said bar and serrated vertically, as described, the similarly-serrated semicircular jaw B', and the lever C, pivoted to the last-named jaw and to the bar, the said lever being of such length that the two jaws will come in contact before the lever assumes a horizontal position, substantially as set forth and shown.

2. The combination, with the movable jaw B', pivoted to the end of a lever, C, of the pivoted dog F and the eccentric D, whereby the movement of the said eccentric is adapted to raise or clamp the said jaw, according as the said dog is in a depressed or elevated position, substantially as described.

3. The pipe-clamp described, adapted to be used as a pipe-wrench, consisting of the mortised bar A, serrated jaws B B', lever C, dog F, and eccentric D, all constructed, arranged, and adapted to operate substantially as set forth and shown.

HENRY M. BRADLEY.

Witnesses:

CHAS. J. HUNT,
H. S. SPRAGUE.