

J. H. HELM.
DIES FOR WELDING LINKS.

No. 193,607.

Patented July 31, 1877.

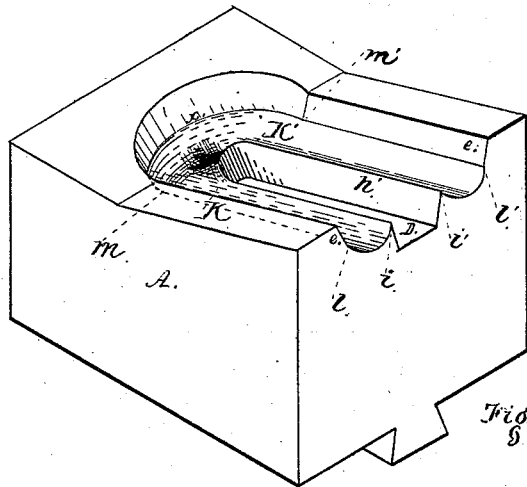

Fig. 1.

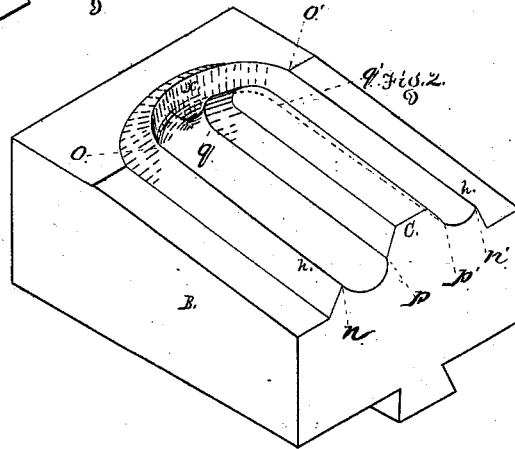

Fig. 2.

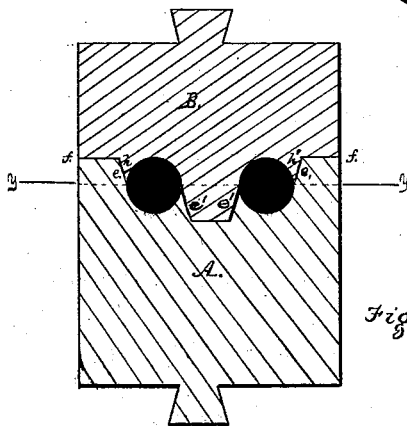

Fig. 3.

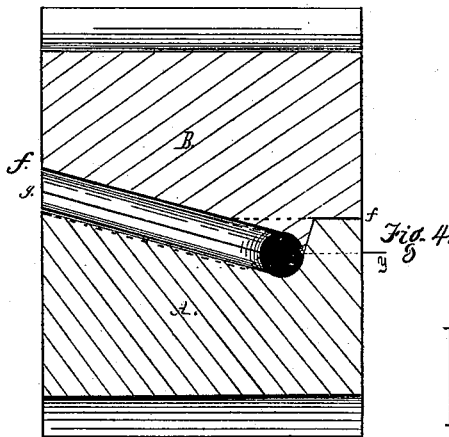

Fig. 4.

WITNESSES.
A. C. Johnston
J. Johnston

INVENTOR
J. Henry Helm

UNITED STATES PATENT OFFICE.

J. HENRY HELM, OF ALLEGHENY, PENNSYLVANIA.

IMPROVEMENT IN DIES FOR WELDING LINKS.

Specification forming part of Letters Patent No. 193,607, dated July 31, 1877; application filed September 8, 1876.

To all whom it may concern:

Be it known that I, J. HENRY HELM, of Allegheny, in the county of Allegheny and State of Pennsylvania, have invented a new and useful Improvement in Dies for Link-Welding Machines; and I do hereby declare that the following is a full and exact description thereof, reference being had to the accompanying drawings, and to the letters of reference marked thereon.

My invention relates to dies for welding chain and other links; and it consists in certain improvements in the construction of the die-blocks and dies hereinafter fully described.

In the accompanying drawings, forming part of this specification, Figure 1 is a perspective view of the stationary die-block. Fig. 2 is a perspective view of the movable die-block. Fig. 3 is a transverse section of the dies, and Fig. 4 is a longitudinal section of the same.

Similar letters of reference indicate corresponding parts in all the figures.

In welding the open ends of chain-links made of round iron by means of dies, one of which is stationary and the other movable, it is necessary that the line of parting of the die-blocks adjacent to the cavity for the reception of the unwelded link should be parallel to and in the same plane with the axis of the iron and the cavity, so that the iron will be easily entered into and removed from the cavity. If the line of parting be above the axis of the cavity, the mouth of the lower die will be contracted, and the same will be the case with the upper die, if the line of parting be below the axis of the cavity.

In either arrangement the iron will not enter the cavity which is contracted; and if the parting be made above or below the line named, and the walls cut away to admit the iron into the cavity, the welded end of the link will not be made into a true circle, but will be given an oval or elliptical form.

The object of my invention is to so construct the dies of a link-welding machine that the iron can be easily entered and removed therefrom, and by turning the link the flash or fin usually formed at the line of parting will be worked into the body of the link; fur-

ther, the construction is such that the force of the movable die is directed against the part of the link to be welded.

To accomplish this result the die-blocks A and B are parted, as indicated at *f* in Fig. 3, and as at *f g* in Fig. 4.

The cavities in the die-blocks A B for the reception of the link lie in an inclined plane parallel to the line *f*, and are bounded on the one side by the V-shaped projections *h h'*, and on the other by the inclines *e e*, respectively forming sloping guide-walls to the die-blocks; but said cavities, unlike those heretofore described, are not of equal and uniform depth throughout their containing-walls, but vary in height, for the purpose hereinafter described.

The inner line *i i'*, Fig. 1, is parallel to the line *f f*, except from the point *k* to the point *k'*, where it dips below the plane of its parallel portions, and the line *p p'*, Fig. 2, rises correspondingly between the points *q q'*, while the outer line *l l'*, Fig. 1, rises between the points *m m'* in like manner, and the line *n n'* dips correspondingly.

In consequence of this arrangement and construction the fin formed on the line of conjunction of the dies and die-blocks is above the plane of the parallel sides of the link or the outside thereof, and below the same plane on the inside thereof, so that when turned over in the die said fin is exposed to the action of the die, and may be struck into the link by repeated blows of the plunger.

It will be observed that the line of parting of the two die-blocks is broken up into different planes, none of which are coincident with the plane of the center of the die proper, and that thereby sloping guide-walls are provided to secure the proper conjunction of the die-blocks.

This feature I do not claim here, it having been made the subject of another application.

I claim—

The die-blocks A B, having inclined faces and cavities, constructed and arranged as described.

J. HENRY HELM.

Witnesses:

A. C. JOHNSTON,
A. J. DAVIS.