

R. G. ROWE & I. B. EDINGTON.
HUB-BORING MACHINE.

No. 193,618.

Patented July 31, 1877.

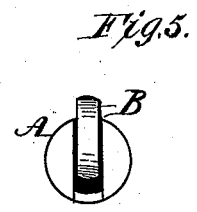
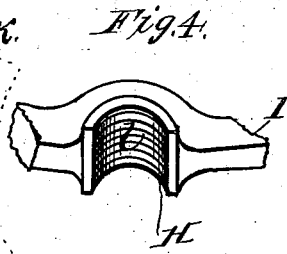
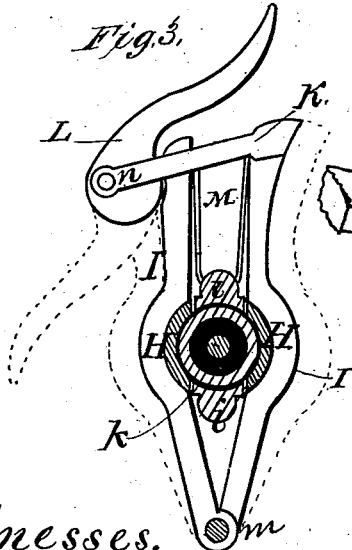
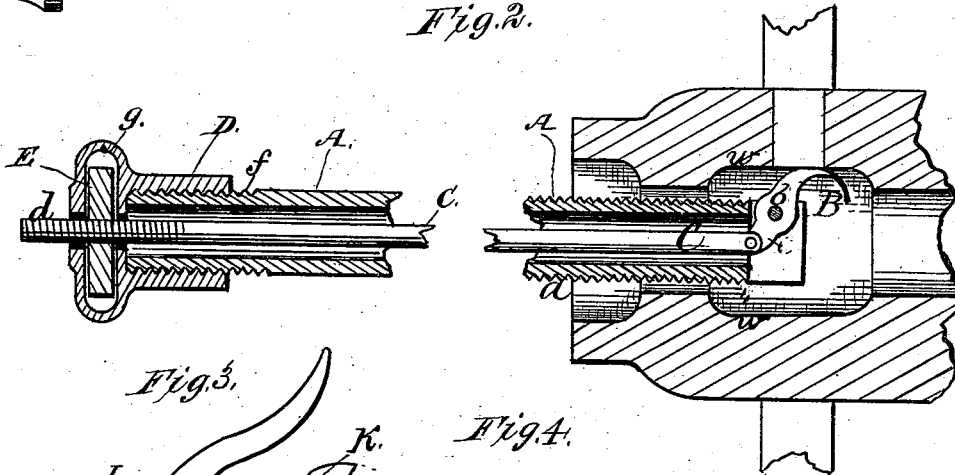
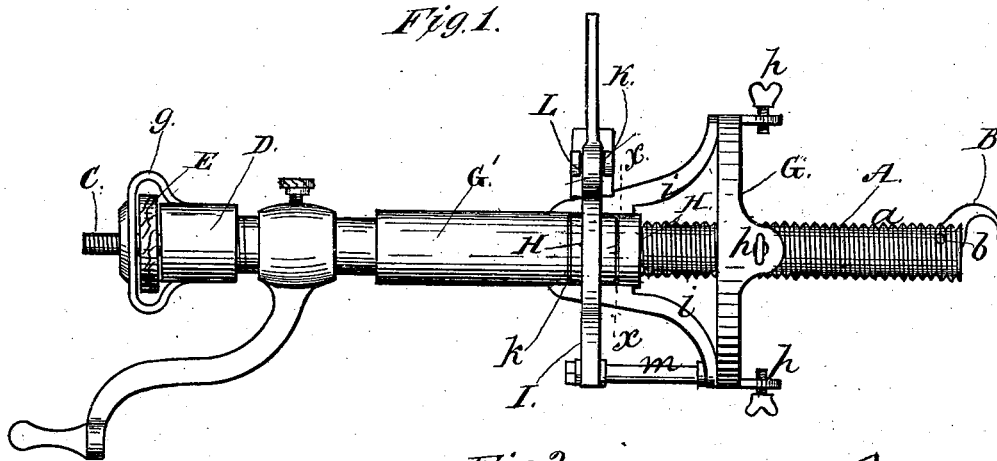

Witnesses.
Edwin Scott
Richard E. White

Inventors.
Rubeen G. Rowe,
Iouac B. Edington,
per R. F. Osgood,
Atty.

UNITED STATES PATENT OFFICE.

REUBEN G. ROWE AND ISAAC B. EDINGTON, OF WATERLOO, NEW YORK.

IMPROVEMENT IN HUB-BORING MACHINES.

Specification forming part of Letters Patent No. 193,618, dated July 31, 1877; application filed November 3, 1876.

To all whom it may concern:

Be it known that we, REUBEN G. ROWE and ISAAC B. EDINGTON, both of Waterloo, in the county of Seneca and State of New York, have invented a certain new and useful Improvement in Hub-Boring Machines; and we do hereby declare that the following is a full, clear, and exact description of the construction and operation of the same, reference being had to the accompanying drawings, in which—

Figure 1 is a plan of our improved apparatus. Fig. 2 is a longitudinal section, showing the central portion broken away and the cutter in the act of enlarging the bore of the hub. Fig. 3 is a cross-section in line *x x* of Fig. 1. Fig. 4 is a perspective view of one of the sectional nuts. Fig. 5 is an end view of the screw-shaft and its cutter.

Our improvement relates to that class of hub-borers in which the machine is clamped to the end of the hub, and a screw-shaft, with the cutter attached thereto, moves through the hub to enlarge the bore. Devices for this purpose are well known.

Our improvement consists of a hollow feeding-screw, a curved cutter pivoted at its extreme end and in advance of the shaft, a rod pivoted to the end of the cutter and extending through the hollow shaft, and a nut or other operating device at the rear for moving the rod.

A represents the feeding-screw, which is a shaft of sufficient length to feed through the hub, having threads *a a* on its outside, and made hollow on the inside to allow the passage of the rod which operates the cutter. B is the cutter. It is a curved blade made sharp on one edge to cut into the wood. It is pivoted at *b* in a slot at the extreme end of the feeding-shaft, so as to project beyond and stand in advance of the shaft, as shown. The curve of the blade is such as to allow the cutter to be turned round at full right angles to the shaft, and yet cut in the wood at any angle. The cutter has a shank, *c*, to which is pivoted the rod C. This rod passes entirely through the hollow feeding-shaft, and projects out at the rear end. A thread, *d*, is formed on the rear end of the rod C. A thread, *f*, is

also formed on the rear end of the shaft A. These two threads have the same pitch and number. D is a collar which screws upon the end of the shaft. E is a nut which screws upon the end of the rod C. This nut rests in a socket or loop, *g*, of the collar, which incloses it, as shown, but allows the nut a free rotation. The socket of the collar holds the nut in a fixed position, so that when the nut is turned, motion will be imparted to the rod in an endwise direction, thereby turning the cutter on its pivot out or in, as the case may be. The loop or socket *g* always retains the nut in place; but as the threads *d f* are of the same pitch and number, both collar and nut may be turned off or on without difficulty.

The rod C, for moving the cutter, might be operated by other means than the nut E—for instance, by an eccentric or wedge—and the effect would be the same; but it is necessary to connect such operating device to the rod at the rear, and outside of the hub, so as to adjust the cutter while within the hub.

G is a circular clamp, which is secured to the end of the hub by set-screws *h h h*. G' is a shank, which is connected with the clamp by curved arms *i i*. The interior of this shank is made larger than the shaft A, so as to slide freely over it.

H H are sectional or half nuts on each side, which rest in slots or openings *k k* of the shank G', and are cut with threads *l*, which engage with the threads *a* of the screw-shaft. The nuts are attached to levers I I, which are pivoted at *m*. When the levers are closed, as shown by full lines, Fig. 3, the nuts rest in engagement with the screw A; but when opened, as indicated in the dotted lines, the nuts are thrown out of engagement. When engaged, the screw will be fed forward. When disengaged the screw is free and can be drawn back at once for a new cut, or wholly withdrawn from the hub, saving the time and labor of turning it back, as is necessary where the screw passes through a solid nut.

K is an arm attached to the outer end of one of the levers, and extending across the end of the other lever. L is an eccentric, pivoted at *n* to the arm, and bearing inward against the lever. When the eccentric is

turned in, the levers will be closed; when turned out, they will be opened. M is a spring between the levers for throwing them open.

We design to connect with the clamp G rods or hooks which will catch around the spokes and hold the clamp against the end thrust in the act of cutting.

Machines of this class are known in which the cutter is made adjustable. The most common form has the cutter fitted crosswise in a slot of the shaft, a little distance back from the end, and held by a set-screw at the end of the shaft.

The special feature of our device is the hollow shaft, having the cutter pivoted in a slot at the extreme outer end, and in advance of the shaft, with a rod connected therewith passing longitudinally through the shaft, and operated by a nut or other device at the rear. By this arrangement a greater range is given to the cutter than usual, and the cutter stands so far in advance of the shaft that it forms its own opening from a bore which is only sufficient to admit the size of the shaft itself. Much space is also saved by running the rod inside instead of outside the shaft, and the same is protected from injury or contact with the wood, being, therefore, surer and more effective in its action. By this means, also, the cutter can be adjusted while in motion and without removing it from the hub.

This apparatus is specially adapted to cutting an enlargement, *w*, in the interior of the

hub, as shown in Fig. 2, so that the ends of the spokes will not touch the box when secured in place. This is readily done by inserting the cutter in the opening and then expanding it, making as many cuts as are necessary to produce the enlargement.

Having thus described our invention, we do not claim, broadly, a feeding-screw with an adjustable cutter attached for enlarging the bore of the hub; but

What we claim as new is—

1. In a machine for boring hubs, the hollow feeding-screw A, the curved cutter B, pivoted in a slot at the extreme end of the screw, and standing in advance of the same, and the rod C, attached to the shank of the cutter, extending through the hollow screw, and operated by a nut or other device at the rear, as shown and described, and for the purpose specified.

2. The machine for boring hubs herein described, consisting of the clamp G, hollow screw A, pivoted cutter B, interior rod C, and the sectional nuts H H, levers I I, and eccentric L, as shown and described, and for the purpose specified.

In witness whereof we have hereunto signed our names in the presence of two subscribing witnesses.

REUBEN G. ROWE.
ISAAC B. EDINGTON.

Witnesses:

FRED. L. MANNING,
GEORGE SALEMAN.