

C. A. WERDEN.
GRINDING-MACHINE.

2 Sheets—Sheet 1.

No. 193,627.

Patented July 31, 1877.

Fig. 1.

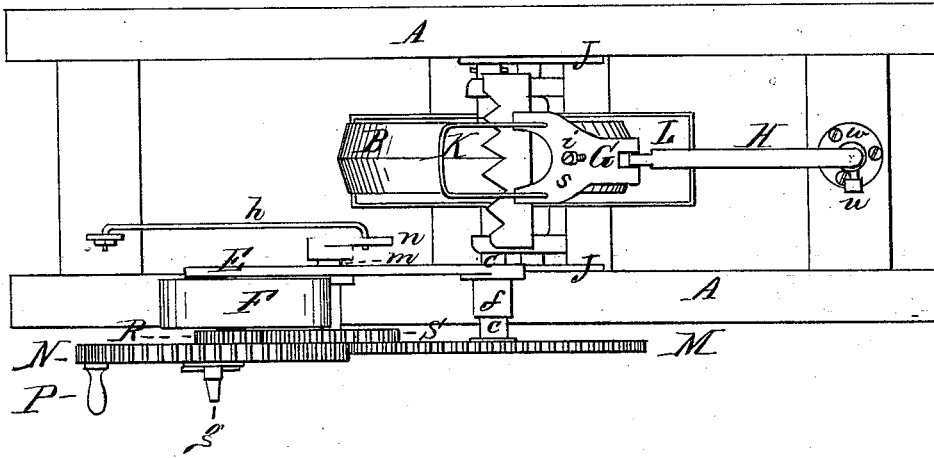
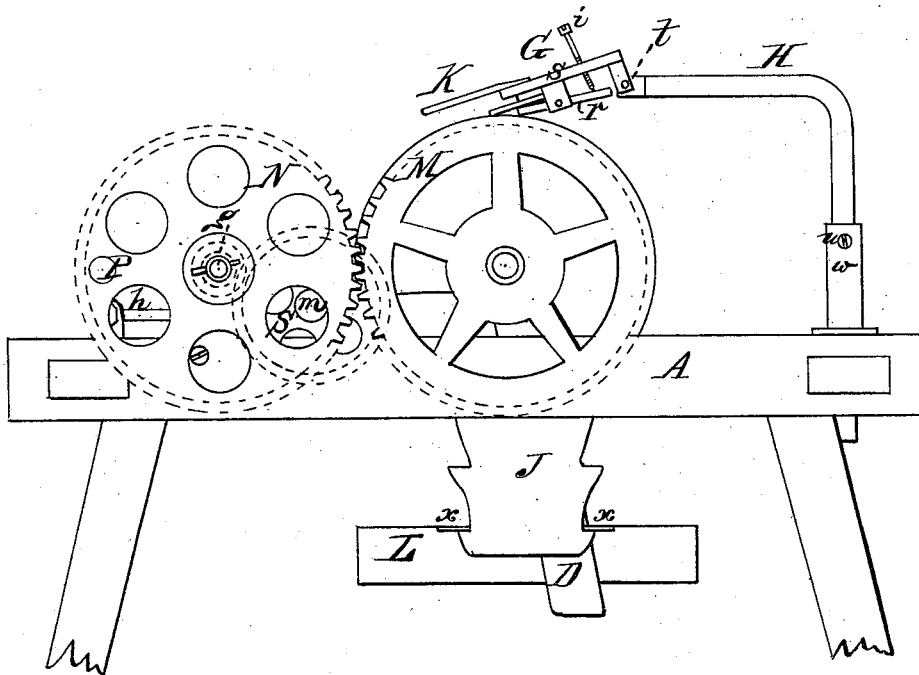

Fig. 2.



Witnesses
H. L. Remond.
W. H. Isaacs.

Inventor
C. A. Worden
by his atty.
C. S. Remwick

C. A. WERDEN.
GRINDING-MACHINE.

No. 193,627.

Patented July 31, 1877.

Fig. 3.

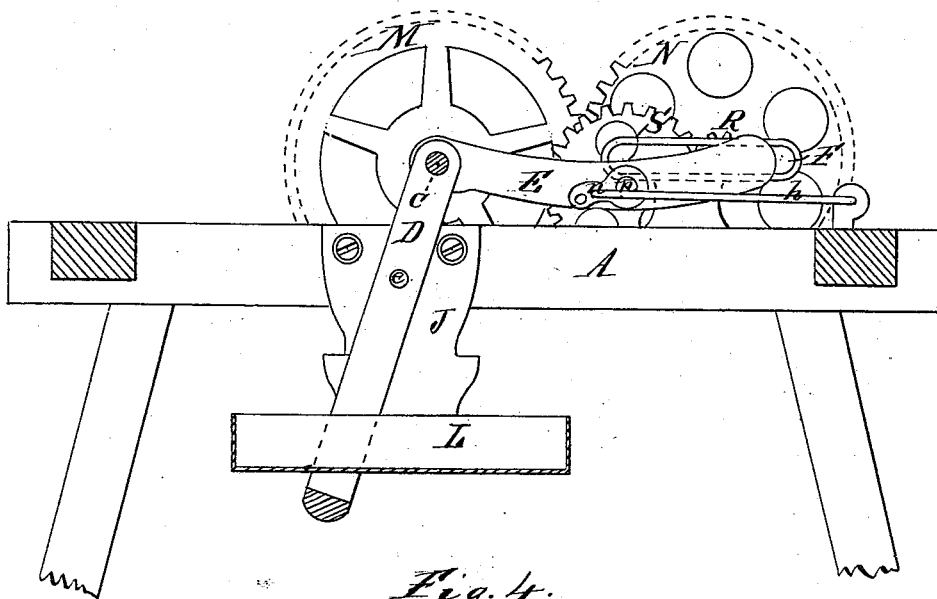

Fig. 4.

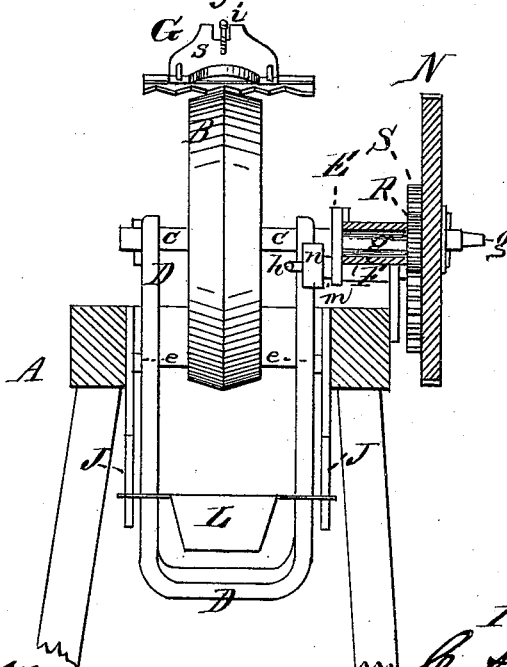

Fig. 5.

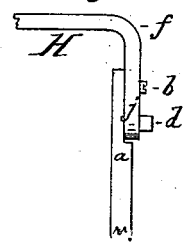
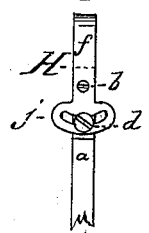

Fig. 6.



Witnesses
H. S. Bennett
W. H. Isaacs.

Inventor
C. A. Werden
by his atty
E. J. Kenwick

UNITED STATES PATENT OFFICE.

CYRUS ALBERT WERDEN, OF WAUKEGAN, ILLINOIS, ASSIGNOR TO HIMSELF
AND WILLIAM B. WERDEN, OF SAME PLACE.

IMPROVEMENT IN GRINDING-MACHINES.

Specification forming part of Letters Patent No. 193,627, dated July 31, 1877; application filed
April 19, 1877.

To all whom it may concern :

Be it known that I, CYRUS ALBERT WERDEN, of Waukegan, in the county of Lake and State of Illinois, have made an invention of certain new and useful Improvements in Grinding-Machines; and that the following is a full, clear, and exact description and specification of the same.

The main object of these improvements is to enable the cutter-blades of mowing-machines to be ground with facility and with rapidity; but the improvements may be employed for any other purpose to which they are applicable.

The improvements consist of certain combinations of mechanical devices, of which the following are the principal, viz: A revolving grinder, which may be constructed of stone or other grinding material, with its edge beveled in opposite directions from a central ridge; a holder or clamp for holding the cutter-bar, whose blades are to be ground; mechanism for causing a reciprocating movement between the revolving grinder and the holder, so that the grinder is caused to act in succession upon the blades from their points to their heels, or vice versa; an adjustable standard for supporting the holder, so that it may be adjusted to present the blades properly to the grinder; a hinge-connection between the holder and its adjustable standard, to enable the blades being ground to be pressed upon the grinder; a water-trough for the grinder; notched hangers for supporting the water-trough of the grinder.

The various combinations which constitute the improvements are specified in detail at the close of this specification. In order that their construction and operation may be fully understood, I have represented in the accompanying drawings, and will proceed to describe, a machine embodying them in the best form in which I have embodied them up to this date.

In the said drawings, Figure 1 represents a plan of the said machine; Fig. 2, a side view of the same; Fig. 3, a vertical longitudinal section of the same; Fig. 4, a vertical transverse section of the same; Figs. 5 and 6 represent modifications of parts of the mechanism.

The various moving parts of the machine are supported upon a strong frame, A. Near the center of this frame is the grinder B, which is fitted to a shaft, C, that is constructed to revolve in a swing-frame, D.

The rim of the grinder B is beveled in opposite directions from a central ridge, so that the form of the grinder is adapted to the bevel of the edges of the blades to be ground.

The swing-frame is fitted to vibrate upon pivots *e*, which connect it with the main frame A, so that the grinder may be reciprocated or moved to and fro bodily, as well as revolved upon its axis.

In order that the grinder may be revolved and reciprocated by the action of a single crank, the following mechanism is employed: The grinder-shaft C is fitted with a link, E, having at one end a tubular box, *f*, which fits upon the grinder-shaft C, and has at its opposite end a stud, *g*, which is parallel with the grinder-shaft, and is supported in a slotted standard, F, so that it may reciprocate therein. A cog-wheel, M, is secured to the shaft of the grinder, and a second or driving cog-wheel, N, is fitted to turn upon the stud *g*, with its teeth engaging with those of the cog-wheel M of the grinder. The driving-wheel N is fitted with a crank-handle, P, by the turning of which that wheel is caused to revolve upon its stud and to drive the grinder.

The interposition of the gearing M N between the grinder and the crank-handle by which it is operated enables the operator to stand in such manner that no part of his body is in the way of holding the harvester cutter-bar directly across the top of the grinder.

The driving-wheel N has a pinion, R, secured to it; and a third cog-wheel, S, of larger diameter than the pinion R, is fitted to a crank-shaft, *m*, which is supported in a box secured to the link E. The teeth of this third cog-wheel engage with those of the pinion R, and the crank *n* of the crank-shaft *m* is perforated with one or more holes, which form wrist-centers. One of these holes is connected with one end of an arm, *h*, whose opposite end is hinged to the main frame. Hence, when the pinion R is turned with the driving-wheel N, it compels the crank-shaft *m* to turn;

and, as the wrist-center of this crank-shaft is connected with the main frame by the hinged arm *h*, while the crank-shaft box is fixed to the link *E*, the said link, the cog-wheels which are connected with it, and the grinder, are all caused to reciprocate slowly while the grinder is revolved.

In order that the cutter-bar may be held to the grinder, the holder *G* is provided. This holder has a stock, *s*, which is connected by a pivot, *t*, or hinge-connection, with the end of a bent standard, *H*. The holder also has a forked clamp, *r*, which is connected with the stock *s* by pivots; and a clamp-screw, *i*, is provided to force the jaws of the clamp toward those of the stock, and thus secure the cutter-bar to the holder. The upright part of the bent standard *H* is fitted in a socket-piece, *w*, and a set-screw, *u*, is provided to clamp the standard fast in the socket. Hence, when the screw is slacked, the standard may be adjusted so as to set the holder at any desired height relatively to the grinder. The holder is provided with a handle, *K*, by means of which the operator can press the blades to the grinder with any desired force.

A water-trough, *L*, is provided to hold water for the grinder. In order that this water-trough may be readily adjusted to the diameter of the grinder, a pair of notched hangers, *J*, are provided to hold it, and the sides of the water-trough are fitted with arms *x x*, which may be engaged with the higher or lower notches of the hangers, so that the trough may be held nearer to or farther from the axis of the grinder, according to its size. This method of supporting the water-trough enables its position to be adjusted readily, and without the use of screws or other devices that might be affected by the dirt incident to grinding.

In using the machine the cutter is secured in the holder with the adjacent edges of two of its blades straddling the ridge of the grinder. The operator then turns the crank-handle with one hand, and presses the blades to the grinder by applying his other hand to the handle *K* of the holder. The revolution of the grinder and the reciprocating motion cause the grinding to be done from the heels to the points of the blades, or vice versa. The extent of the reciprocating movement may be adjusted by connecting the end of the vibrating arm *h* with one or other of a series of holes in the crank *n*.

In case there be any part of the edges of the blades which require extra grinding, (as, for example, a nicked part,) the vibrating arm *h* may be disconnected from the crank when the grinder is opposite the said part, whereupon the reciprocating movement will be intermittent, and the movement of the crank-handle *P* will cause the grinder to revolve only.

The construction of the reciprocating mechanism may be varied as found expedient; and when the vibrating arm is disconnected a clamp-screw with a wing-nut may be used to clamp the grinder fast in its position.

In some cases it is expedient to use a grinder whose rim is not beveled. In such cases the horizontal arm of the bent standard *H* is made separately from the upright part thereof, as represented at Figs. 5 and 6, and is connected with the upright part *a* through the intervention of a pivot, *b*, so that the horizontal part *f* may be rocked to the right or to the left to cause the holder *G* to apply the blade properly to the grinder. A clamp-screw, *d*, is provided to secure the arm in the desired position, and the shank *j* of the arm is slotted to form a bearing for the head of this screw.

What is claimed as the invention to be secured by Letters Patent, is—

1. The combination, substantially as before set forth, of the revolving grinder, the knife-holder, the hinge-connection between the holder and its support, the main frame, the swing-frame, the link carrying the crank-shaft of the reciprocating mechanism, and the arm which connects the crank of the crank-shaft with the main frame.

2. The combination, substantially as before set forth, of the main frame, the grinder, the swing-frame, the link carrying the crank-shaft, and the gearing which drives the grinder and the crank-shaft, and the arm connecting the crank of the crank-shaft with the main frame.

3. The combination, substantially as before set forth, of the revolving grinder, the notched hangers for the water-trough, and the water-trough fitted with arms to engage with said hangers.

Witness my hand this 1st day of December, A. D. 1876.

CYRUS ALBERT WERDEN.

Witnesses:

JAMES B. WELCH,
W. B. BESLEY.