

R. SCHRADER.
 PITMAN-ROD CONNECTIONS FOR STEAM-ENGINES.
 No. 193,730. Patented July 31, 1877.

Fig. 1.

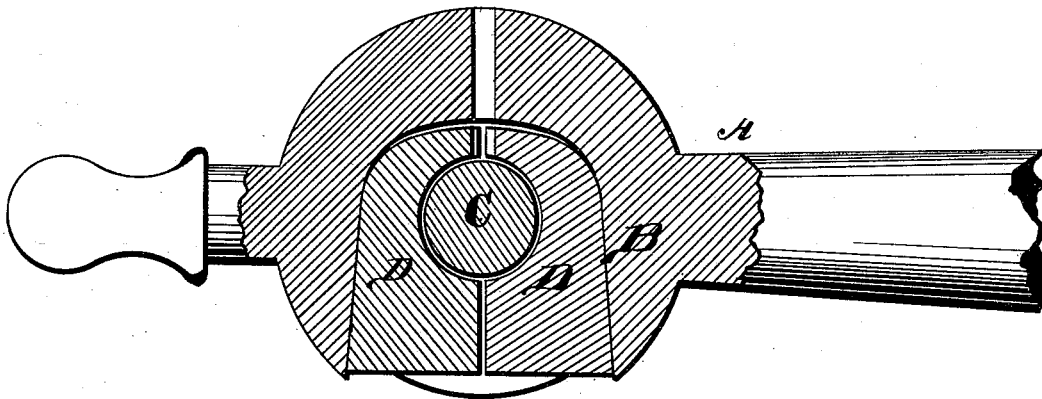

Fig. 2.

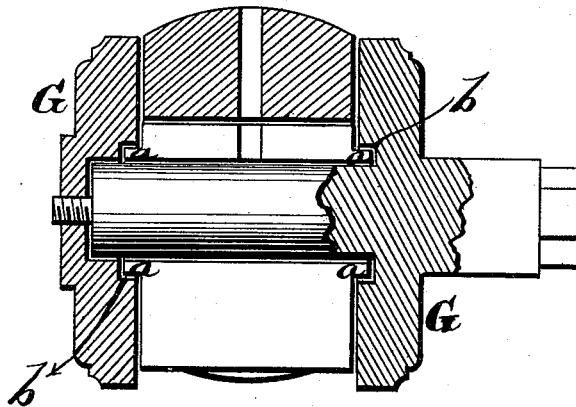
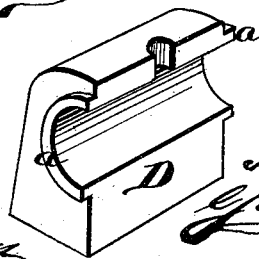

Fig. 3.



WITNESSES
Robert Consett
George C. Upham

INVENTOR.
Rudolph Schrader.
Gilmore, Smith & Co.

ATTORNEYS.

UNITED STATES PATENT OFFICE.

RUDOLPH SCHRADER, OF INDIANAPOLIS, INDIANA.

IMPROVEMENT IN PITMAN-ROD CONNECTIONS FOR STEAM-ENGINES.

Specification forming part of Letters Patent No. 193,730, dated July 31, 1877; application filed July 7, 1877.

To all whom it may concern:

Be it known that I, RUDOLPH SCHRADER, of Indianapolis, in the county of Marion and State of Indiana, have invented a new and valuable Improvement in Pitman-Rods; and I do hereby declare that the following is a full, clear, and exact description of the construction and operation of the same, reference being had to the annexed drawings, making a part of this specification, and to the letters and figures of reference marked thereon.

Figure 1 of the drawings is a representation of a horizontal sectional view of the joint of my pitman-rod. Fig. 2 is a transverse vertical sectional view; and Fig. 3 is a perspective detail, of the same.

The nature of my invention consists in the construction and arrangement of a pitman-connection for steam-engines, as will be hereinafter more fully set forth.

The annexed drawing, to which reference is made, fully illustrates my invention.

A represents the end of the pitman formed with a cam-hook, B, and C is the rest for said cam-hook. These parts are used on all engines which are made with rock-shafts; but heretofore the cam-hook was made with a common round rest, so that only the two outside corners would work, and this often brought on lock-motion, which could not be stopped. In my invention I use the same hook; but it is made slightly tapering, in such a manner that the mouth of the hook is wider than the inner or upper end thereof. On the rest C is placed a box, made in two equal parts, D D, constructed as shown—that is to say, when put

together, the top of the box is half-round and the sides made tapering or inclined to fit the taper of the cam-hook B. On the ends of the two parts of the box D D are formed circular tenons *a a*, which enter and fit into corresponding grooves *b b*, made in the inner faces of the heads or disks G G, which are secured to the rest C, and between which the cam-hook B is placed on said box.

With this invention the objection to the ordinary cam-hook and rest is entirely obviated, because the rest works all over even, and the box can easily be made to fit the hook properly by means of the taper, as described.

The bisected box D may be made of brass or any other suitable metal.

What I claim as new, and desire to secure by Letters Patent, is—

1. The combination of the cam-hook B, made tapering, as described, the rest C, and the longitudinal bisected box D D, having its sides made tapering, substantially as and for the purposes herein set forth.

2. The longitudinal bisected box D D, having tapering sides, and the ends provided with circular tenons *a a*, in combination with the rest C, heads G G, with grooves *b b*, and the cam-hook B, substantially as and for the purposes herein set forth.

In testimony that I claim the above I have hereunto subscribed my name in the presence of two witnesses.

RUDOLPH SCHRADER.

Witnesses:

CYRUS T. NIXON,
CYRUS LAUGHLIN.