

W. JONES.
HORSE-DETACHING APPARATUS.

No. 193,764.

Patented July 31, 1877.

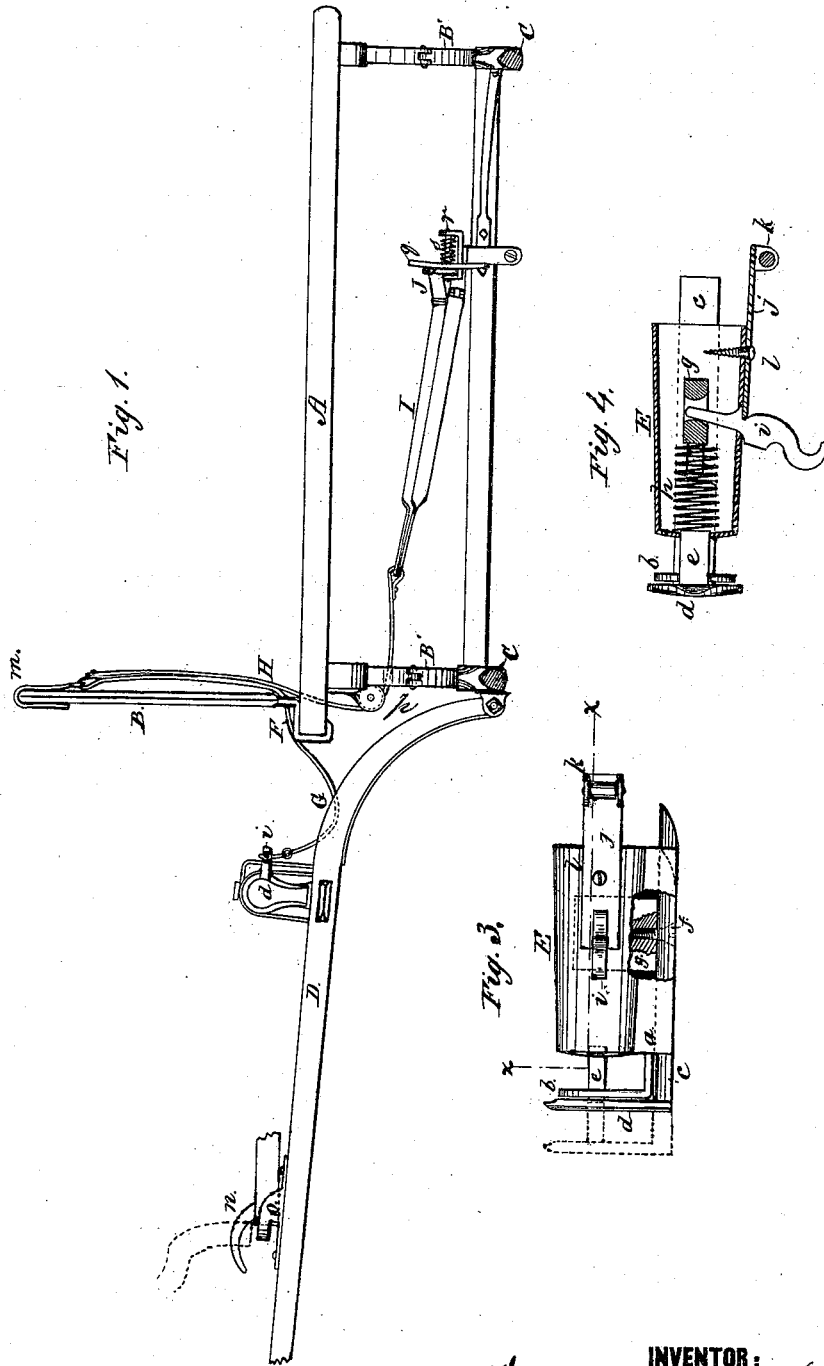

WITNESSES:

W. W. Hollingsworth
Geo. A. Kemmon

INVENTOR:

Warren Jones

BY

Russell B.

ATTORNEYS.

W. JONES.
HORSE-DETACHING APPARATUS.

No. 193,764.

Patented July 31, 1877.

Fig. 2.

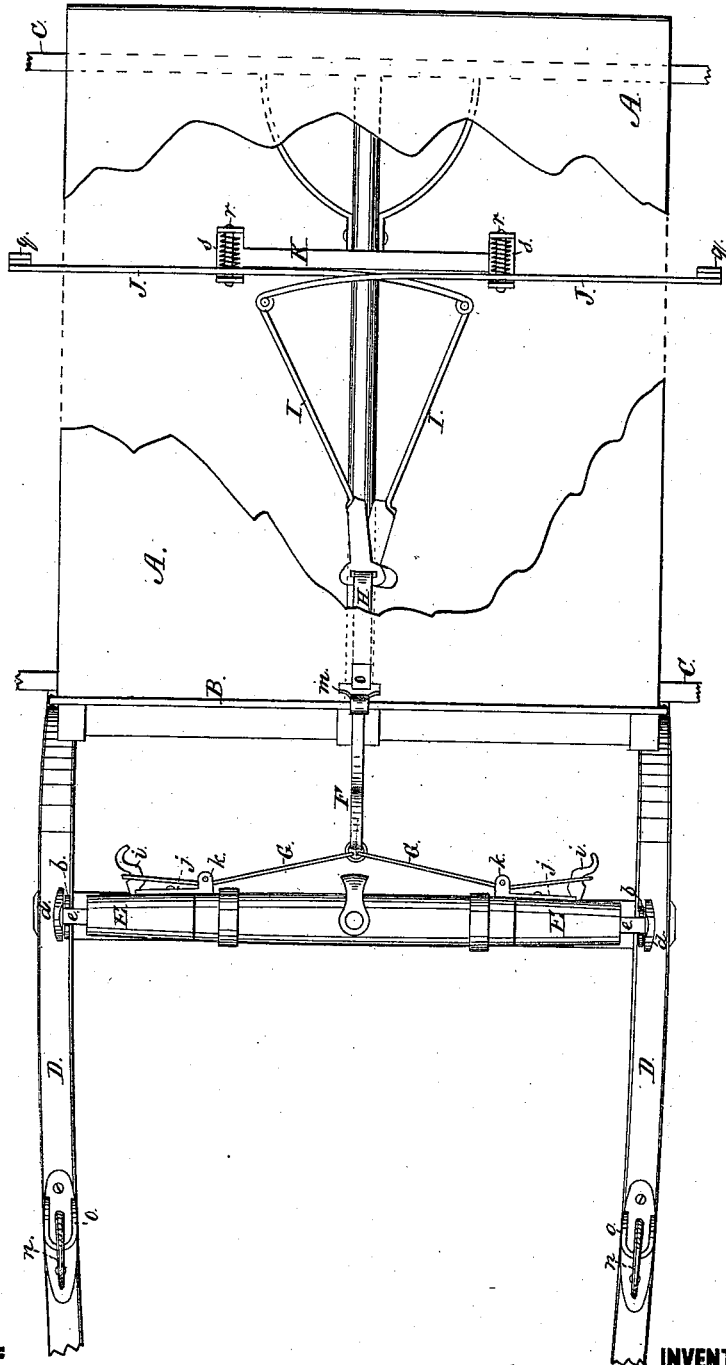

WITNESSES:

W. W. Hollingsworth
George Kenon

INVENTOR:

Warren Jones

BY

Allen T. C.

ATTORNEYS.

UNITED STATES PATENT OFFICE.

WARREN JONES, OF BERLIN, WISCONSIN.

IMPROVEMENT IN HORSE-DETACHING APPARATUS.

Specification forming part of Letters Patent No. 193,764, dated July 31, 1877; application filed July 21, 1877.

To all whom it may concern:

Be it known that I, WARREN JONES, of Berlin, in the county of Green Lake and State of Wisconsin, have invented a new and Improved Horse-Detaching Apparatus; and I do hereby declare that the following is a full, clear, and exact description of the same, reference being had to the accompanying drawing, forming part of this specification, in which—

Figure 1 is a side view of my devices applied to a part of the running-gear. Fig. 2 is a plan view, with a part of the body-platform broken away to show the brake; Fig. 3, a detail side view of the whiffletree-ferrule and its attachment; Fig. 4, a horizontal section of the same on the line *x x*, Fig. 3.

The object of my invention is to provide an improved horse-detaching apparatus for vehicles, designed to enable the driver to entirely disconnect the vehicle from the team without getting out of the vehicle, either for convenience in practical every-day use, or for special emergencies in the event of a runaway or fall of the horse.

To this end the improvement consists, mainly, in the particular construction and arrangement of a locking-stud for the trace, combined with the whiffletree, so as to be moved outwardly from the end thereof to release the trace; in the arrangement of a bent, slotted, or forked plate for pulling the trace off the stud, for guiding the latter, and for the purpose, also, of operating as a stop to the slide carrying the stud; and in the combination, with the said detaching devices, of a peculiar form of brake for simultaneous and joint operation therewith, as hereinafter more fully described.

In the drawing, A represents the platform, B the dash-board, C C the axles, B' B' the springs, and D D the shafts, of any ordinary carriage, buggy, or wagon, to which my improvements are shown applied. The detaching devices for the traces are shown at E E upon the extremities of the whiffletree, and they consist each of a ferrule, formed with dovetailed guideways *a* upon the lower side of the same, and a bent fork, *b*, at its outer end. In the guide *a* is arranged, longitudinally with the whiffletree, a dovetailed slide, *c*, which has, at its outer end, a right-angular vertical extension, *d*, that carries a horizontally-projecting stud, *e*, which latter rests in

the fork *b*, and is guided thereby in its movement with the slide, so as to register with an opening in the end of the ferrule. This stud *e* constitutes the part to which the trace is directly attached, and upon which the draft-strain comes, and in attaching and detaching the trace said stud is moved longitudinally with the whiffletree, to enter or be withdrawn from the eye of the trace placed between the fork *b* and the end of the ferrule. In securing this movement of the stud the slide *c*, to which it is attached, is connected with a follower-block, *g*, in the ferrule by means of a screw, *f*, which passes through a slot in the bottom of the ferrule, which slot is of sufficient length to permit the necessary movement. This block rests against a spiral spring, *h*, in the end of the ferrule, which, by reason of its tension, habitually keeps the block and slide back, and consequently holds the projection *d* against the fork, and the end of the stud *e* in the hole in the end of the ferrule, to secure the trace, whose eye encompasses said stud. To retract this stud, either for fastening on the trace or for detaching the same, a lever, *i*, is fulcrumed in the ferrule, so as to project laterally therefrom, and the inner end of said lever is loosely connected with the block *g* by means of a slot, so that when the said lever is deflected it presses the block against the spring and moves the slide and the attached locking-stud outwardly to the position indicated in dotted-lines in Fig. 3, either to adapt the device to receive the trace or to disengage the latter. The fork in this connection, it will be seen, serves not only to guide the stud and compel it to register with the hole in the end of the ferrule, but also acts as a stop to the slide, and serves, in disengaging the trace, to pull it off of the stud, or rather to prevent it from following the stud in its movement. The lever *i* is inserted laterally through a slot in the ferrule, and is secured in place by a plate, *j*, which closes the slot and forms a fulcrum, upon which a notched portion of the lever works. This plate is formed with an eye, or preferably with ears, carrying a friction-roller, *k*, as shown, and the same screw *l* secures both the plate to the ferrule and the ferrule to the end of the whiffletree.

Instead of using the lever *i* for operating the locking-stud *e*, I may arrange other de-

vices in the place of the same, to operate by a more direct action.

To facilitate the insertion of the traces, the ends of the levers *i* are formed with thumb-pieces. To operate, however, the two devices upon opposite ends of the whiffletree simultaneously and together for detaching the team, a strap, *F*, is arranged just inside the dash-board, and passing underneath the same. One end of the strap, for convenience, is provided with a flattened hook, *m*, which is hooked over the top of the dash-board to keep it within easy reach, while the other end is connected with two branch-straps, *G G*, which extend respectively through the eyes or around friction-roller *k k*, and are attached to the ends of the levers *i*, so that to disengage the traces all the driver has to do is to pull upon the strap *F*.

As, however, in the event of a runaway, the disengagement of the traces alone would not reach the desired end if the connection of the breeching with the shafts were still preserved, I have attached to the thills a hold-back or connection for the breeching, which, when the traces are released and the horse moves forward, is automatic in its disengagement. These holdbacks consist simply of forwardly-curved hooks or horns *n*, attached to base-plates screwed to the shafts, and surrounded in front and upon the sides by a guard, *o*, also affixed to the base-plate. This guard serves to prevent the breeching-strap from passing over the hook from loose play so long as the traces are fastened and the horse is partly behind the holdbacks; but when the horse is detached his movement forward brings the breeching-straps into the position shown in dotted lines in Fig. 1, in which the forward curve of the hook or horn permits the straps to rise over the guard and be automatically disengaged.

In many cases, in securing safety from a fractious or runaway team, the mere detaching of the same will be sufficient; but, to prevent the vehicle from being smashed against fences or buildings, and in traveling over hilly country, or over roads bounded by deep ditches, gullies, or precipices, it is very necessary that the independent motion of the vehicle should be checked after the team is detached, and held in check until the occupants have alighted. To secure this result I have combined with the detaching devices a brake, which is brought into simultaneous and joint operation with the same by the same movement which effects the disengagement of the team.

I attach to the same strap *F* that operates the detaching devices a second strap, *H*, which latter passes around a friction-roller, *p*, under the body of the vehicle, to the loops formed on the forward end of two draft-bars, *I I*, made of light strap-iron. The rear portion of these draft-bars is jointed to the ends of two light but stiff levers, *J J*, bearing upon their opposite ends brake-shoes *q q*, which

bear against the hind wheels, and furnish the desired friction, the middle parts of said levers being fulcrumed in the ends of a cross-bar, *K*, bolted in suitable position on the reach of the running-gear. In arranging the fulcrum of the levers *J J* the latter are perforated, and receive a bolt, *r*, fixed in upturned ears or lugs formed on the ends of the cross-bar *K*, and around said bolts are arranged spiral springs *s*, which hold the levers and their brake-shoes away from the wheels, but allow the same to be projected against the wheels by a draft on the strap *H* and the draft-bars *I*.

I am aware of the fact that it is not broadly new to employ a horse-detaching apparatus and a brake, in combination with each other, for simultaneous and joint operation; and I therefore claim only the combination of these two features when the latter are constructed as shown and described, which effects the desired result in a better manner.

Among the advantages of my improvement, in addition to those already set forth, are, facility of attaching as well as of detaching, the efficient co-operation of the several features of the invention, and the compactness and complete inclosure of the detaching devices, the latter being so completely shut in as to obviate the access of dirt to the same, and the obstruction which its presence would produce.

Having thus described my invention, what I claim as new is—

1. The spring-actuated slide *c*, carrying extension *d* and stud *e*, in combination with the ferrule, having longitudinal guideways for the slide, and means for operating the same, substantially as described.

2. The ferrule provided with a bent fork, *b*, and combined with the slide *c*, extension *d*, and locking-stud *e*, for the purpose of guiding the latter, pulling off the trace, and operating as a stop to the extension against the tension of the spring, substantially as described.

3. The detaching devices, consisting of a ferrule provided with guideways *a* and a bent fork, *b*, combined with the slide *c*, carrying extension *d* and stud *e*, the follower-block *g*, the spring *h*, lever *i*, and straps *F G G*, substantially as and for the purpose described.

4. The fulcrum-plate *j*, combined with the notched lever *i* and the slotted ferrule, for the purpose described.

5. The combination, with the detaching devices *E* upon the ends of the whiffletrees and the straps *F G G* connected therewith, and provided with a hook, *m*, of the brake *I J K*, having a strap, *H*, arranged in its draft-bars, and connected with the strap *F*, for the simultaneous and joint operation of the brake and the detaching devices, as described.

WARREN JONES.

Witnesses:

SOLON C. KEMON,
CHAS. A. PETTIT.