

W. M. KEPLER.  
IRONING-BOARD.

No. 193,765.

Patented July 31, 1877.

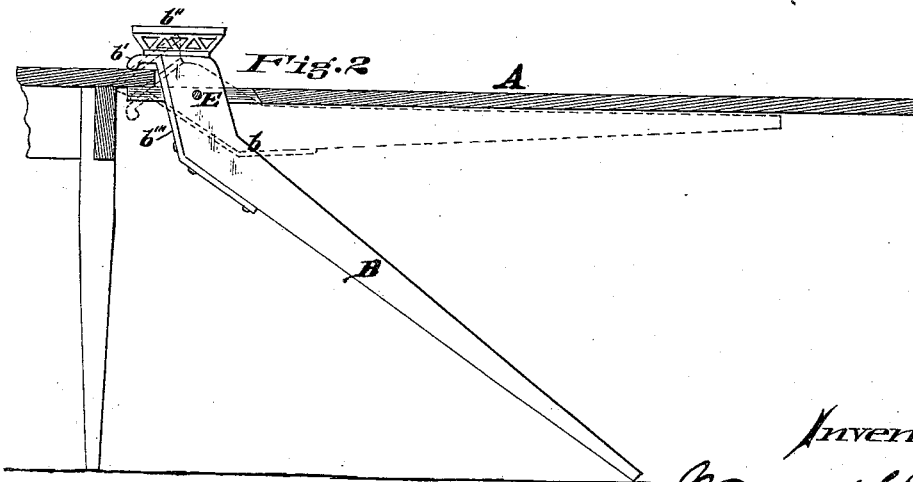
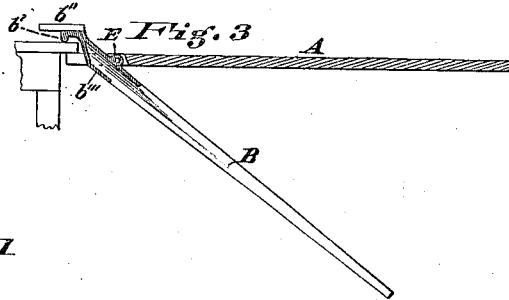
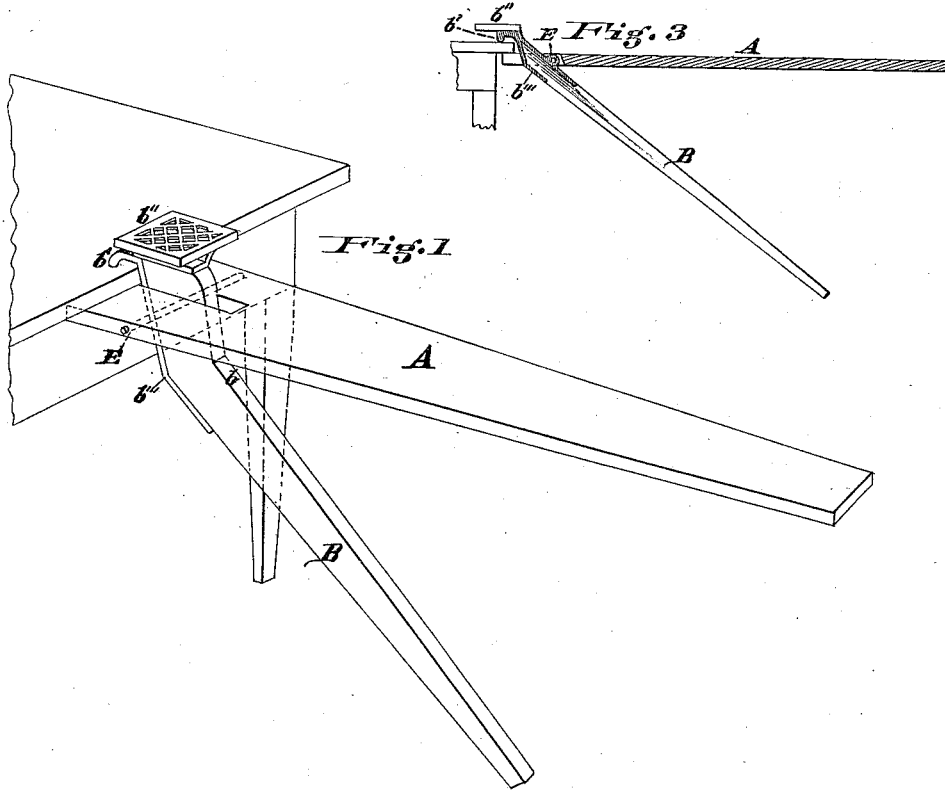

Attest  
*Edgar Cross*  
*John C. Jones.*

Inventor  
*Wm. M. Kepler*  
By *W. Millward*  
Attorney

# UNITED STATES PATENT OFFICE.

WILLIAM M. KEPLER, OF CINCINNATI, OHIO, ASSIGNOR TO HIMSELF AND EDWARD W. BISHOP, OF WINCHESTER, INDIANA.

## IMPROVEMENT IN IRONING-BOARDS.

Specification forming part of Letters Patent No. 193,765, dated July 31, 1877; application filed June 8, 1877.

*To all whom it may concern:*

Be it known that I, WILLIAM M. KEPLER, of Cincinnati, Hamilton county, State of Ohio, have invented an Improvement in Ironing-Boards, of which the following is a specification:

Ironing-boards have heretofore been made composed of two parts, each adapted to receive clothes for ironing, one a wide board for general work, and the other a narrow one for sleeve-work. These have been hinged together near one end, so as to gripe a table by the use of perforated ears attached to one side of the wide board, and the whole has been reversible, to permit either board to be used while the other acts as a floor-brace. This construction is open to serious objections, as the employment of the ears gives great weight to the article, and both parts, being ironing-boards, are necessarily arranged relatively in parallel planes, and consequently the one which acts as a brace is illy adapted to perform that office, its greatest width being in the wrong direction for a brace.

My invention is designed to remedy these defects.

It consists in providing the hinge in the body of the wide board, and constructing the other member so that it can act as a brace only, it being arranged with its greatest width in the line of the strain, and so that it can fold up close, although its hinge is in the middle of the wide board.

Figure 1 is a perspective view of an ironing-board embodying my invention. Fig. 2 is a vertical section of the same. Fig. 3 is also a vertical section of the same in a modified form.

A is the ironing-board, and B the brace.

They are arranged, with relation to each other, so that the direction of greatest width of board A is at right angles to the line of greatest width of the brace B. This being the case, the brace B can be very light in structure, although adapted to perform its office as a brace perfectly. The parts A B are hinged together by a pivot-pin passing, at E, through the body of the board A, midway in its thickness, and also through an eye of the brace B. In order to permit the brace to fold up close, I place the pivot-pin above the line of its face *b* a distance equal to half the thickness of board A, as shown, by either cutting the brace to the form shown in Fig. 2, or attaching a casting to form the projection, as in Fig. 3. The brace is provided with a projecting lip, *b'*, to rest on the table, and a stand, *b''*, for the support of the iron, and the lip is a part of a strengthening-strap, *b'''*, which runs down the edge of the brace, to which it is securely fastened. In Fig. 3 two straps project from the lip, in one of which the hinge is formed, as shown, the two straps straddling the brace, so as to make a firm connection therewith.

I claim—

The combination of board A, centrally perforated at E for the pivot-pin, with the brace B, pivoted thereto in a plane at right angles to the board A, and having its said pivot above the plane of its upper edge, so as to permit the folding close of the hinged members.

In testimony of which invention I hereunto set my hand.

WM. M. KEPLER.

Witnesses:

J. L. WARTMANN,  
W. H. BELLOWS.