

L. J. McCORMICK, W R. BAKER & L. ERPELDING.
HARVESTERS.

No. 193,770.

Patented July 31, 1877.

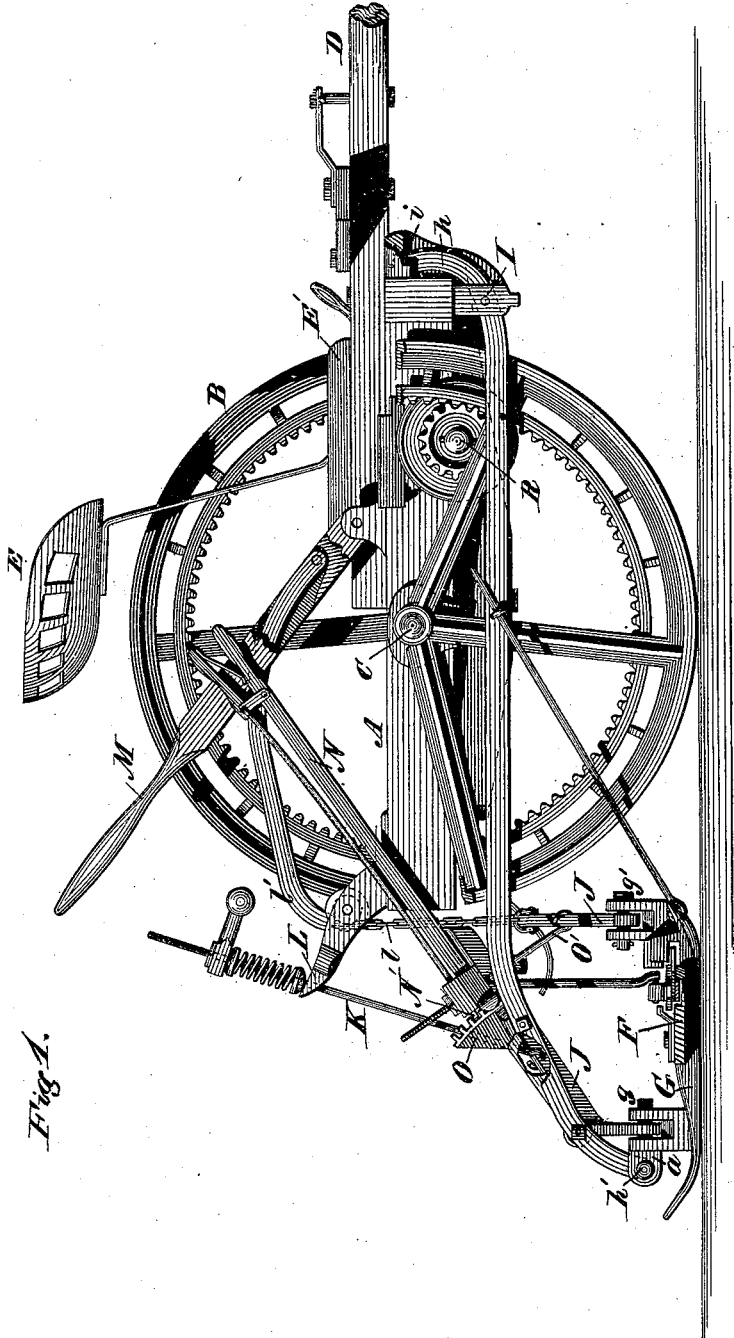

Fig. 1.

WITNESSES.

Harry King
Wm J. Peyton

B11

L. J. McCormick, W. R. Baker & L. Erpelding
 INVENTORS

Wm D. Baldwin *Attorney*

4 Sheets—Sheet 2.
 L. J. McCORMICK, W. R. BAKER & L. ERPELDING.
 HARVESTERS.

No. 193,770.

Patented July 31, 1877.

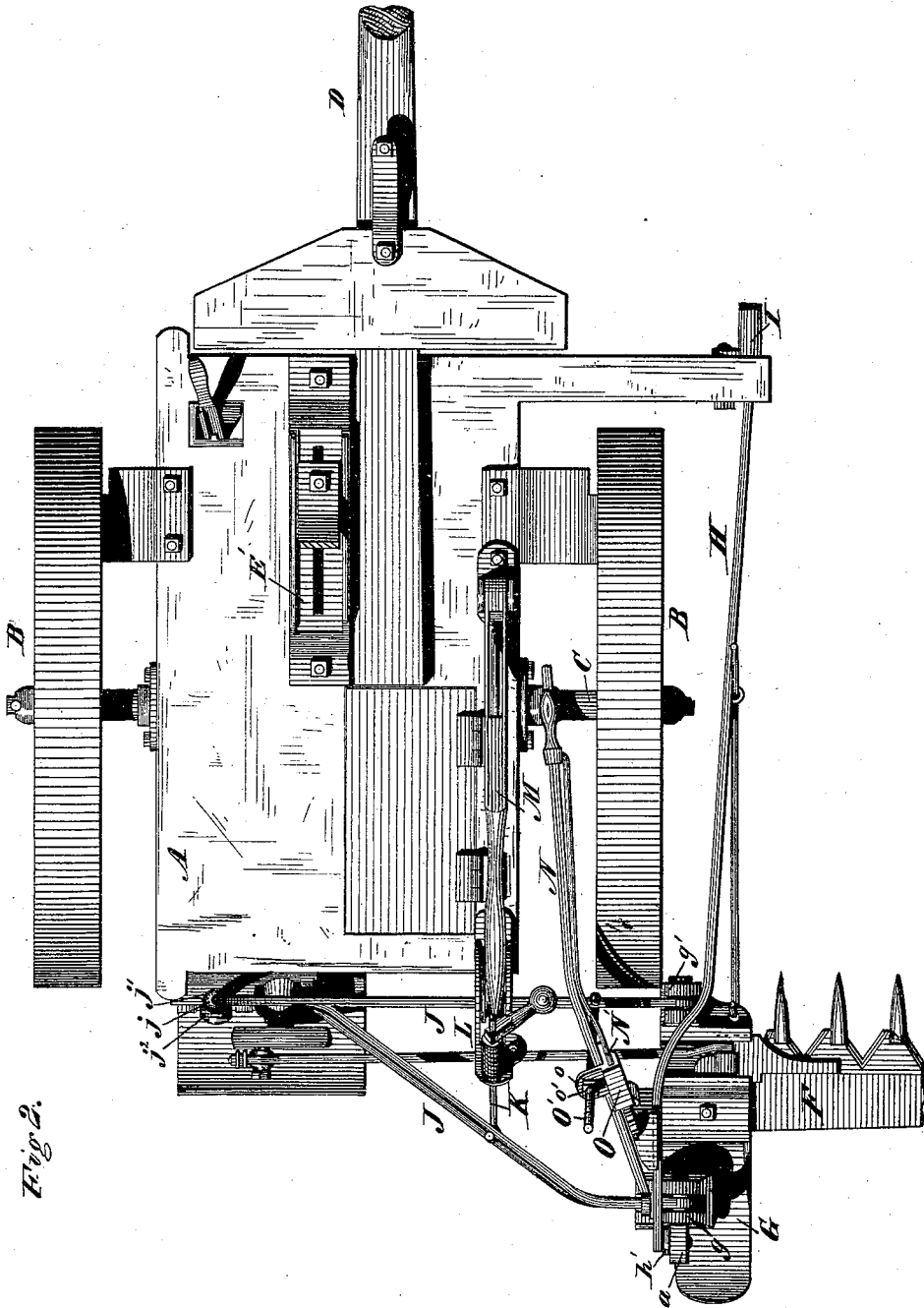

Fig. 2.

WITNESSES
Harry King
Wm J. Payton

INVENTOR
L. J. McCormick, W. R. Baker & L. Erpelding
 By their Attorney
Wm D. Baldwin

4 Sheets—Sheet 3.
 L. J. McCORMICK, W R. BAKER & L. ERPELDING.
 HARVESTERS.
 No. 193,770.
 Patented July 31, 1877.

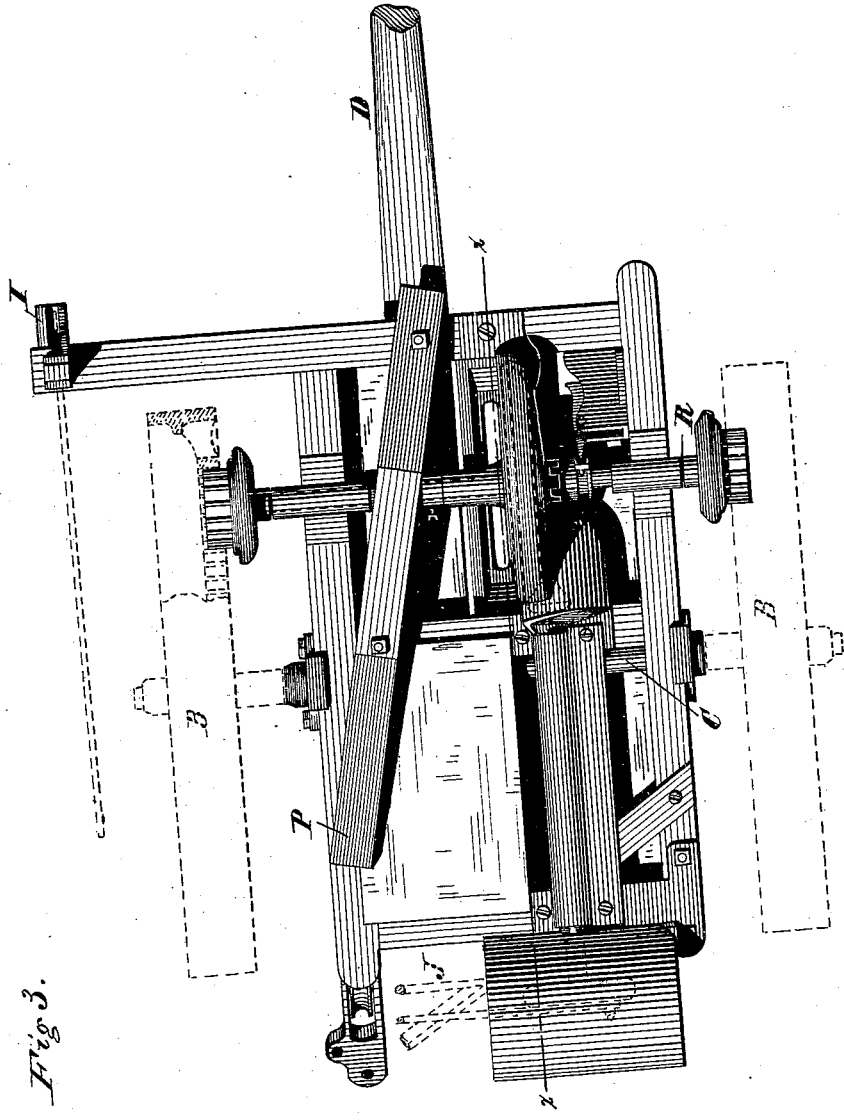

Fig 3.

WITNESSES

Harry King not.
Wm J. Peyton

INVENTOR

L. J. McCormick, W. R. Baker & L. Erpelding

By *their* Attorney

Wm D. Baldwin

L. J. McCORMICK, W R. BAKER & L. ERPELDING.
HARVESTERS.

No. 193,770.

Patented July 31, 1877.

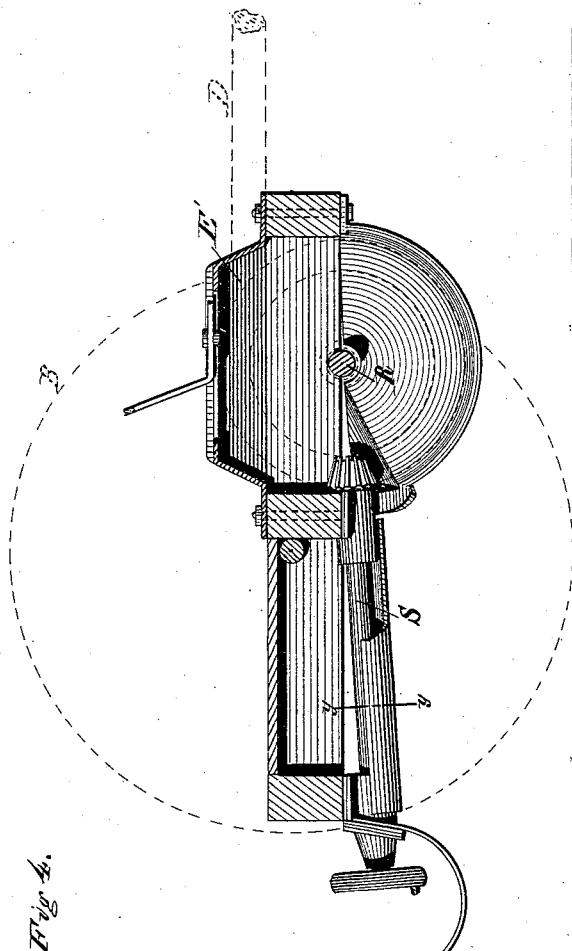

Fig. 4.

Fig. 5.



WITNESSES
Harry King
Wm. J. Taylor

L. J. McCormick, W. R. Baker & L. Erpelding
 INVENTOR
 By their Attorney

Wm. Baldwin

UNITED STATES PATENT OFFICE.

LEANDER J. McCORMICK, WILLIAM R. BAKER, AND LAMBERT ERPELDING,
OF CHICAGO, ILLINOIS, ASSIGNORS TO C. H. AND L. J. McCORMICK, OF
SAME PLACE.

IMPROVEMENT IN HARVESTERS.

Specification forming part of Letters Patent No. 193,770, dated July 31, 1877; application filed
July 17, 1875.

To all whom it may concern:

Be it known that we, LEANDER J. McCORMICK, WILLIAM R. BAKER, and LAMBERT ERPELDING, all of Chicago, in the county of Cook and State of Illinois, have invented certain new and useful Improvements in Harvesters, of which the following is a specification:

The subject-matter claimed will hereinafter specifically be designated.

In the accompanying drawings our improvements are shown as embodied in a two-wheel hinged-bar mowing-machine.

Figure 1 is a view from the grain side of the machine, the cutting apparatus and a portion of one wheel being broken away to more clearly show the parts claimed; Fig. 2, a plan or top view, the driver's seat being removed; Fig. 3, a bottom view, the cutting apparatus being removed; Fig. 4, a longitudinal sectional view of the support for the driver's seat, crank-shaft, protecting-plates, &c.; and Fig. 5, a view in cross-section of the crank-shaft and protecting-plate on the line *yy* of Fig. 4.

The main frame *A* is supported by driving-wheels *B B*, mounted and turning on an axle, *C*, held in suitable bearings on the frame. A tongue, *D*, projects from the top side and front of the main frame. A seat, *E*, for the driver, is mounted on a box-casting, *E'*, which forms a cover for the main bevel-gear wheel, and is adjustable backward and forward thereon by means of guide-ledges and a slot and set-screw.

It will be observed that the seat is mounted in advance of the main axle, the object of which is to enable the driver to see well in advance of the cutters, and to counterbalance the weight of the parts on the rear of the machine.

The finger-beam *F* is secured to the shoe *G* in the usual way. A drag-bar, *H*, lies parallel with the drive-wheels, and has its front end curved upward to form a hook, *h*, which passes through a slot in a down-hanger, *I*, located on the inner front corner of the main frame, in which it is pin-jointed, the extreme end of the hook entering a guide-slot or recess, *i*, on the upper portion of the down-

hanger, the object of which, while the drag-bar is free to move up and down around its pivot, is to prevent it from turning over sideways.

The rear end of the drag-bar is bent inward and downward, Figs. 1 and 2, a sufficient space being preserved beneath it to allow the shoe and its joints to play freely, and terminates in a laterally-projecting pin, *h'*, which enters a socket in a swiveling eyebolt, *a*, on the rear end of the shoe, and forms the pivot on which the shoe, and consequently the finger-beam, rocks.

The shoe *G* is also provided in front and rear with lugs *g g'*, to which are respectively pin-jointed the front and rear members of a forked coupling-arm, *J*, the swiveling eyebolt *a* forming the pivot of the rear member. The end of this coupling-arm is bent or curved, like a "goose-neck," to pass over the crank-shaft, and terminates in a ball, *j*, working in a socket, *j'*, in the crank-box casting, the socket being covered by a cap, *j''*, thus forming a ball-and-socket joint, which allows the finger-beam to rise and fall, and to rock freely without cramping.

The pressure of the cutting apparatus upon the ground is regulated by means of a link, *K*, hooked at one end to the rear fork or member of the coupling arm, and passing through an overhanging bracket, *L*, mounted on the inner rear corner of the main frame, the link above the bracket being surrounded by a spring, the tension of which may be regulated by a screw-nut working on the link.

The cutting apparatus is raised and lowered by a chain, *l*, hooked to the front fork of the coupling-arm, passing over a pulley journaled in the overhanging bracket *L*, and connected by an arched link, *l'*, with a slotted lifting-lever, *M*, pivoted on the main frame within convenient reach of the driver. It is obvious the range of lift of the cutting apparatus by this lever can be varied by attaching the link *l'* to the lever nearer to or farther from its fulcrum, and that, owing to its construction and manner of connection with the link, the link acts as a stop to limit the backward motion of the lever by abutting against the

of the slot in which it is pivoted. The lifting apparatus may be rocked on its pivoting pivot-joint, and held in any desired position to adapt it to rough as well as smooth land, by means of a rocking lever, N, pivoted to the drag-bar and extending to the convenient reach of the driver, the lever being provided with a spring-detent, N', taking into a curved rack, O, also mounted upon the drag-bar, a lifting-link, O', hooked to the front member of the forked coupling-arm, passing loosely through an opening in the extended portion of a bracket, o, mounted on the rocking lever, through which the detent works, to engage the curved rack, the lifting-link above this bracket being provided with an adjustable screw-nut, o', whereby it will be seen that when the cutting apparatus is adjusted the screw-nut will prevent its descent beyond its adjusted point, until the detent is withdrawn from the rack, while allowing it to rise to pass over obstructions.

Instead of this lifting-link O', a chain might be used, and by the employment of a rigid strap the cutting apparatus, when adjusted by means of the rack, would be held in a fixed position.

We have found that the weight of the cutting apparatus on the inner rear corner of the main frame has the effect of springing and twisting the frame, by which the boxes are tightened and the machine made heavy to move. This tendency is overcome by a diagonal brace, P, extending the entire length of the frame, its front end being bolted to the under side of the frame, preferably by the same bolt that passes through the tongue and front cross-piece, another bolt passing through the brace and center cross-piece close to the main axle, a bolt at the rear end not being essential.

On the inner surfaces of the drive-wheels are cast spur-wheels, which mesh with and drive corresponding pinions mounted on a counter-shaft, R, turning in bearings on the frame in front of the main axle. This counter-shaft carries a beveled-gear wheel, which drives a corresponding pinion on the crank-shaft S, the crank-shaft being supported in suitable bearings and driving the cutters by a crank and pitman, as usual.

Suitable plates or casings surround the crank-shaft and bevel-gear wheels to protect them.

We have described our improvements as organized for operation as a two-wheel hinged-bar mowing-machine, but they are also adapted for the reception of parts necessary to constitute a hand-raking or self-raking reaper.

We claim as our invention—

1. The combination, substantially as hereinbefore set forth, of the slotted and grooved down-hanger, and the hooked front end of the drag-bar pivoted therein, and guided and braced thereby.

2. The combination, substantially as hereinbefore set forth, of the shoe and the drag-

bar, extending over and in rear of the shoe, and its swivel-pin connecting it with the rear end of the shoe, whereby the drag-bar sustains the thrust of the shoe while leaving it free to rock on its hinges.

3. The combination, substantially as hereinbefore set forth, of the shoe, the drag-bar extending over and in rear of the shoe, the swivel-pin connecting the two, and the forked coupling-arm, the front member of which is pivoted to the front of the shoe, while its rear member is pivoted to the swivel-pin of the drag-bar, whereby great flexibility of movement and a firm bracing of the shoe is secured.

4. The combination, substantially as hereinbefore set forth, of the lateral brace or coupling-arm attached to the front of the shoe, the drag-bar hinged to the rear of the shoe, and the lifting-lever pivoted upon the drag-bar and linked to the lateral brace to tip the cutters.

5. The combination, substantially as hereinbefore set forth, of the shoe, the forked coupling-arm, the drag-bar extending over and in rear of the shoe, the swivel-pin connecting the two, the rocking lever and detent mounted on the drag-bar, and the adjustable-link connection between the lever and the coupling-arm, whereby the shoe readily may be rocked or adjusted.

6. The combination, substantially as hereinbefore set forth, of the shoe, the drag-bar extending over and in rear of the shoe, the swivel-pin connecting the two, the forked coupling-arm, the overhanging bracket on the frame, and the adjustable spring-tension link connecting the bracket and the rear member of the forked coupling-arm, whereby the pressure of the shoe upon the ground may be regulated.

7. The combination, substantially as hereinbefore set forth, of the shoe, the drag-bar, the forked coupling-arm, the overhanging bracket on the frame, the adjustable spring-tension link connecting the bracket and the rear member of the forked coupling-arm, and the chain, link, and lifting-lever acting on the front member of the coupling-arm, whereby the shoe is first rocked and then lifted by one continuous movement of the lever.

8. The combination, substantially as set forth, of the coupling-arm, the chain attached thereto, the link attached to the chain, and the pivoted slotted lever in which the link is pivoted, whereby the link acts as a stop to the backward movement of the lever while allowing it to move forward freely to lift the coupling-arm.

In testimony whereof we have hereunto subscribed our names.

LEANDER J. McCORMICK.
WM. R. BAKER.
LAMBERT ERPELDING.

Witnesses:

R. NEWTON,
D. McINTYRE.

L. M. J. Baker