

R. A. COWELL.

YIELDING CAR-PLATFORMS.

No. 193,851.

Patented Aug. 7, 1877.

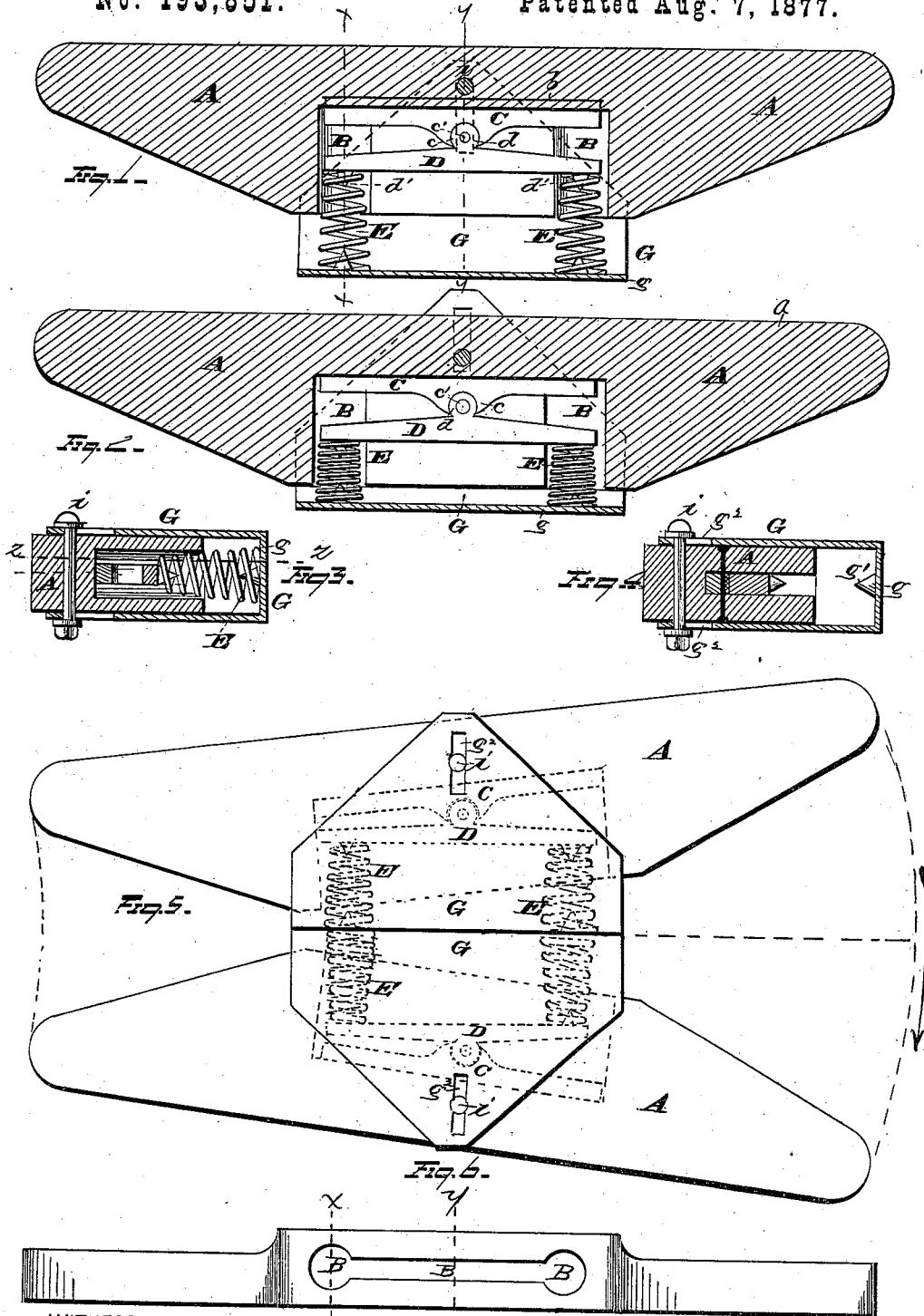

WITNESSES  
*Ed. J. Nottingham*  
*A. M. Wright*

INVENTOR  
*R. A. Cowell,*  
*By Leggett and Leggett,*  
ATTORNEYS

# UNITED STATES PATENT OFFICE.

RENSELAER A. COWELL, OF CLEVELAND, OHIO.

## IMPROVEMENT IN YIELDING CAR-PLATFORMS.

Specification forming part of Letters Patent No. 193,851, dated August 7, 1877; application filed May 18, 1877.

*To all whom it may concern :*

Be it known that I, RENSELAER A. COWELL, of Cleveland, in the county of Cuyahoga and State of Ohio, have invented certain new and useful Improvements in Supplemental Yielding Platforms for Cars; and I do hereby declare the following to be a full, clear, and exact description of the invention, such as will enable others skilled in the art to which it pertains to make and use it, reference being had to the accompanying drawings, which form part of this specification.

My invention relates to railway-car platforms, and is an improvement on the device for which Letters Patent No. 110,901, dated January 10, 1871, were granted to me; reissue No. 4,846, dated April 2, 1872. It consists of a supplemental yielding platform, as will be hereinafter fully described and claimed.

In the drawing, Figure 1 represents a horizontal cross-section of my device taken on the line *z z* of Fig. 3. Fig. 2 is a similar view, showing the supplemental platform in a different position relative to the cross-head, and the springs compressed. Fig. 3 is a vertical cross-section taken on line *x x*, Figs. 1 and 6. Fig. 4 is a similar view taken on line *y y*, Figs. 1 and 6. Fig. 5 represents the relative position of two contiguous cars while passing a curve. Fig. 6 is a longitudinal side view of the cross-head, with supplemental platform removed.

The cross-head A or front sill of the platform is secured to the body of the car in the same manner as described in the patent above referred to, or in any other suitable and effective way. Said cross-head is recessed for the purpose of receiving part of the mechanism which operates in connection with the supplemental yielding platform. The recess is, preferably, made deep, so as to accommodate a spring of considerable length. *b* is a metal bar secured in the bottom of said recess B, and serves the purpose of a bearing-plate. Its employment is not an essential feature of my invention, and it may be dispensed with, if desired. C is the bearing-plate, the under or flat side of which rests on the bar or plate *b*, or on the bottom of the said recess. It is provided with a slot, socket, or other suitable aperture, *c*, as shown, in which fits a similar-

shaped projection, *d*, of the spring-carrying lever or arm D. When the projection of the arm D is inserted in the curved opening *c* the arm D can then swing from side to side, and can be said to be pivoted to the bearing-plate C. If desired, an opening, *c'*, may be made in the projection *d*, and a bolt passed through it and the cross-head to strengthen and to assist in holding the parts in place; but that is not essential to the successful operation of the device, or the bolt *i* may pass through the opening *c'*. The projection *d* is curved on the line of a circle to correspond with the aperture *c*, the former fitting closely, but moving freely in the latter. D is the spring-carrying lever or arm, provided at each end with a projection, *d'*, around which the end of a spring is secured. E E are spiral springs of suitable size, shape, and strength, fastened in any suitable manner to the arm D, or merely placed over the projections, so as to abut against said arm. To the vertical side *g* of the supplemental platform G are fixed the projections *g'*, by which the opposite ends of the springs E are held in position against the inside face of said vertical side of the yielding platform. G is the supplemental yielding platform proper, formed of one or more pieces of metal, and shaped so as to embrace the cross-head A, as shown in Figs. 3 and 4. The upper and lower sides of this platform, near the inner edge, are provided with slots, *g''*, to accommodate a bolt, *i*, which passes through them and the cross-head A. These slots *g''* permit the yielding platform to slide over the draw-head when pressure is exerted on the supplemental platform, which pressure compresses the springs, as shown in Fig. 2. When no pressure is exerted against the platform it will extend beyond the cross-head, as shown in Fig. 1, by reason of the action of the springs E. When the pressure is perpendicular to the vertical side *g* of the platform it will then compress the springs, as shown in Fig. 2, and the arm D will remain parallel with the rear side *a* of the cross-head, both springs being equally compressed. The pressure brought to bear on the arm D from the springs is transmitted to the bearing-plate C by means of the projection *d*, and distributed through the same. Thus a greater force can be successfully re-

sisted than if the arm D were pivoted on a bolt.

When two cars provided with my device are coupled together, the ends of the supplemental platforms abut against each other, as shown in Fig. 5.

The advantage of the pivoted arm D is evident when the cars are passing along a curve. In that case the tendency is to compress the spring nearer the inner curve of the track more than the spring nearer the outer curve; but that tendency is immediately overcome by the pivoted arm D, which is caused by the springs always to assume a position parallel to the vertical side *g* of the yielding platform, so that the springs are always equally compressed, and consequently the supplemental platforms always press firmly against each other, whether or not the cars are passing a curve. Without the use of the pivoted arm D one spring would be more compressed than the other when the train is running on a curve. It would also have a tendency to twist it out of its position, and the supplemental platforms could not, with the same degree of certainty, be kept in contact. It is evident that in place of spiral springs rubber springs could be employed with the same result. It is also evident that more than two springs may be employed, placed at suitable distances apart.

Instead of forming the arm D with a projection, and the plate C with a recess, the construction may be the reverse—that is, the arm D may be provided with a recess, and the plate C with a projection.

I do not confine myself to the particular construction of joint here shown, as any device by which a rocking motion is permitted to the arm D is within the spirit of my invention.

What I claim is—

1. The combination, with the spring-controlling arm centrally pivoted to a cross-head, and the supplemental platform of the springs directly connecting the extremities of the said arm with the respective end portions of the platform, substantially as described.

2. The combination, with a spring-controlling arm pivoted within a recessed cross-head, of the supplemental platform directly bearing against pressure-springs, the said platform fitting about the cross-head and having its tread-board sliding freely over the same, substantially as described.

3. The combination, with the spring-controlling arm, pivoted to a cross-head and formed with front stud projections, of the supplemental platform formed with counter projections, and the intermediate springs fitting over the said projections, substantially as described.

4. The combination, with the recessed cross-head A, of a bearing-plate, C, and spring-controlling arm D, pivoted in said bearing-plate, substantially as and for the purpose described.

5. The combination, with the recessed cross-head A, of a bearing-plate, C, spring-controlling arm D, springs E, and supplemental yielding platform G, the latter provided with slots *g*<sup>2</sup>, and secured to the cross-head through the medium of a bolt, substantially as and for the purpose described.

In testimony whereof I have signed my name to this specification in the presence of two subscribing witnesses.

RENSELAER A. COWELL.

Witnesses:

WM. BEHRENS,

W. E. DONNELLY.