

J. FRICKER, Jr., & A. SEINECKE.

BALLOT-BOXES.

No. 193,862.

Patented Aug. 7, 1877.

FIG. 1.

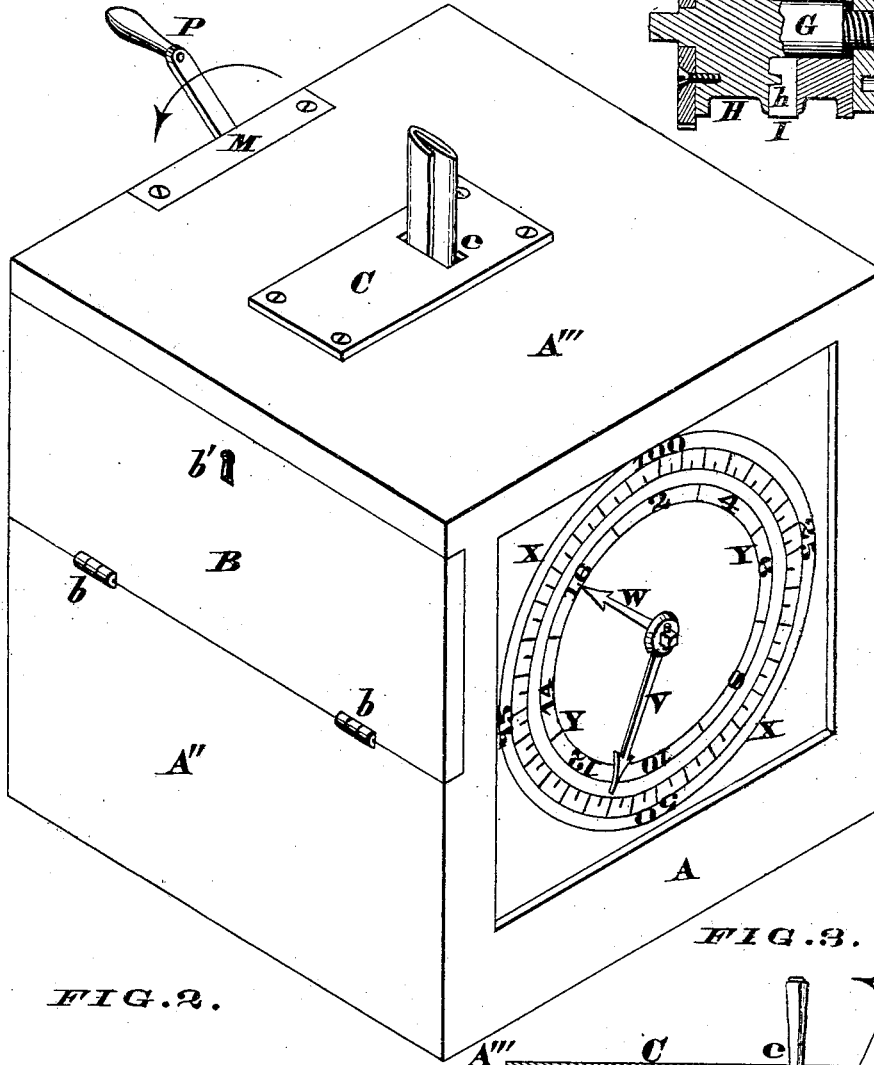

FIG. 4.

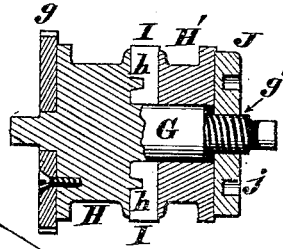
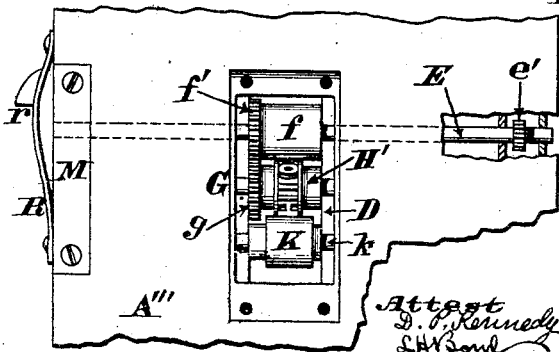
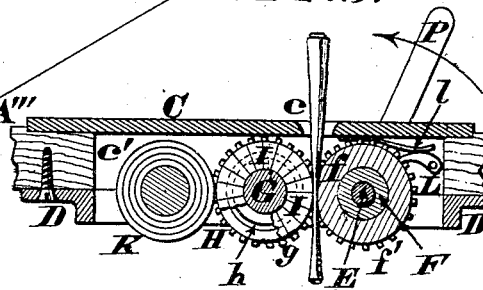

FIG. 2.



Attest
 D. P. Kennedy,
 S. H. Bond

FIG. 3.



Inventor -

Jacob Fricker Jr.
 Adolph Seinecke
 by James H. Seayman
 Attorney

J. FRICKER, Jr., & A. SEINECKE.

BALLOT-BOXES.

No. 193,862.

Patented Aug. 7, 1877.

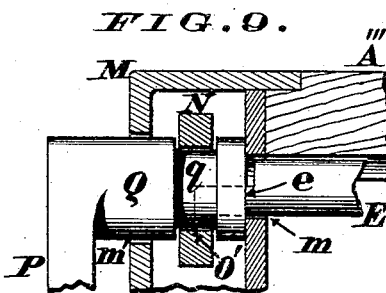
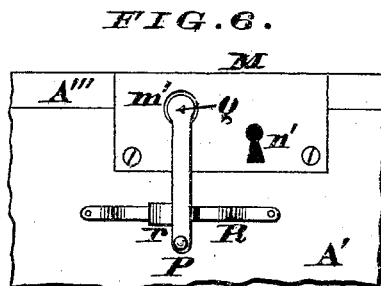
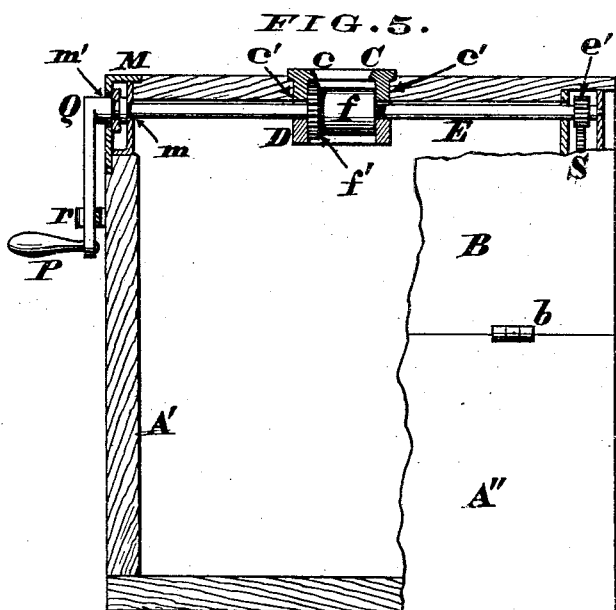

FIG. 4.

FIG. 8.

FIG. 10.

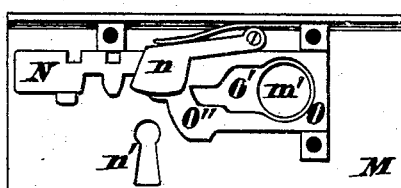
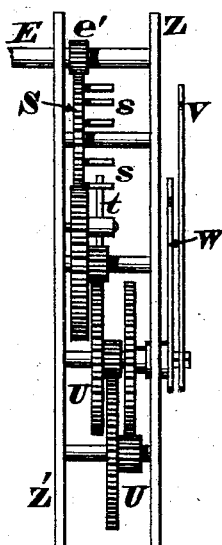
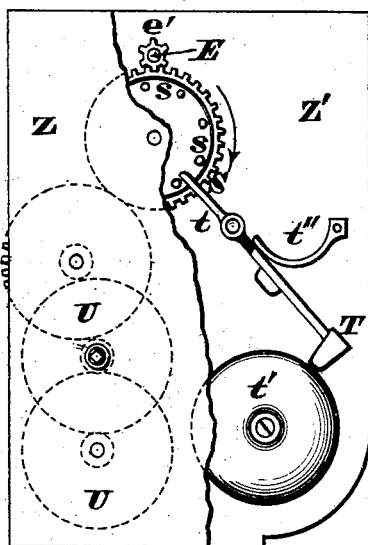

FIG. 11.

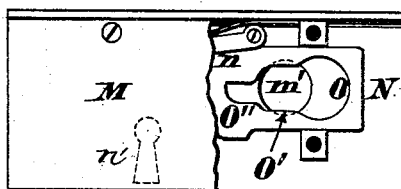
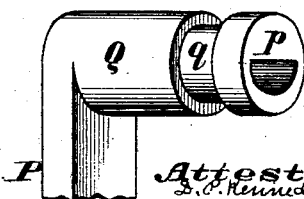
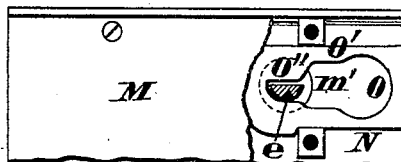

FIG. 12.



Attest.
S. O. Kennedy,
Notary Public

Inventor
Jacob Fricker Jr. Adolph Seinecke
by James H. Loayman
Attorney.

UNITED STATES PATENT OFFICE.

JACOB FRICKER, JR., AND ADOLPH SEINECKE, OF CINCINNATI, OHIO.

IMPROVEMENT IN BALLOT-BOXES.

Specification forming part of Letters Patent No. **193,862**, dated August 7, 1877; application filed March 29, 1877.

To all whom it may concern:

Be it known that we, JACOB FRICKER, Jr., and ADOLPH SEINECKE, both of Cincinnati, Hamilton county, Ohio, have invented certain new and useful Improvements in Ballot-Boxes, of which the following is a specification:

Our invention consists in constructing ballot-boxes in such a manner as to afford a three-fold security against the casting of fraudulent votes, which result we accomplish as follows: The ticket, after being folded in the usual way, is inserted in a slot in the top of the box, at which moment the custodian of the apparatus turns a crank so as to force the ticket completely down through said slot and deposit it in the box. This positive descent of the ticket is effected by means of two oppositely-revolving rollers, one of which is armed with types or other devices that print upon the descending ticket the name of the city or ward, or the locality of the polls. Or the ticket may be canceled by printing upon it any suitable combination of characters or symbols, &c.

The moment the ballot is deposited a gong or bell is struck one blow, thereby giving audible notice to all bystanders of a vote having been cast, and simultaneously with this sounding of the bell a pointer or hand, or a pair of such devices, indicates the vote upon an exposed dial or face at one end of the box. Furthermore, the box is constructed in such a manner as to prevent these indicating-hands being tampered with or set in any way until the box has been opened by the proper officers and the votes duly counted.

In the accompanying drawing, Figure 1 is a perspective view of our ballot-box, a ticket being shown as in the act of being deposited in the same. Fig. 2 is a plan of a portion of the top of the box, the slotted plate through which the ballots are deposited being removed. Fig. 3 is a transverse section through the devices that cancel the tickets and force them into the box. Fig. 4 is a longitudinal section through the type-roller. Fig. 5 is a vertical section of the box in the plane of the driving-shaft. Fig. 6 represents the normal position of the operating-crank of said shaft. Fig. 7 is a front elevation of the bell-striking apparatus.

Fig. 8 is a side elevation of the same. Fig. 9 is a vertical section through the lock of the box, the crank being coupled to the driving-shaft. Figs. 10, 11, and 12 represent three different positions of the two-throw bolt of said lock; and Fig. 13 is a perspective view, showing the operating-crank detached from the driving-shaft.

A represents the front end, A' the rear end, A'' one side, and A''' the top, of our box, which receptacle may be composed of any suitable material, and of such capacity as to contain as many tickets as are generally polled in a single ward or precinct. Access is had to this box by means of a door, B, hinged to the side A'' at *b*, and provided with a secure-lock, *b'*. Firmly fastened to the top of the box is a plate, C, slotted at *c*, and provided with two downwardly-projecting flanges, *c'*, which latter serve as a cap for the box D. This box is secured to the under side of top A''', as seen in Figs. 3 and 5. Journaled in this box D, and extending from the front to the rear end of cover A''', is a driving-shaft, E, having at one end a segmental or non-circular arbor, *e*, and at the other end a pinion, *e'*. Mounted upon this shaft, so as to rotate therewith, and located within box D, is a roller or cylinder, F, covered with a cushion or pad, *f*, of india-rubber or leather, or any other yielding material. (See Fig. 3.)

Cylinder F carries a gear-wheel, *f'*, that meshes with wheel *g* of the type-roller. This roller consists of a shaft, G, and two heads, H H', between which latter are clamped the radial types I, as seen in Figs. 3 and 4. Head H has an annular tongue or rib, *h*, that enters suitable grooves in the sides of these removable types.

These types may be arranged so as to print upon each and every ticket either the number of the ward or the name of the precinct, or any other appropriate inscription; or they may cancel the tickets by printing upon them any desired combination of characters or symbols. Head H' is forced against the types by means of a nut, J, that engages with the threaded portion *g'* of shaft G. This nut is rotated by the insertion of a suitable implement in either one of a series of sockets, *j*, formed in the exposed side of said nut.

Adapted to be driven by contact with roller H H' I is an inking-roller, K, whose shaft *k* is journaled in box D. This roller may be wrapped with cloth, or any other material that will retain a sufficient quantity of moderately-fluid ink or other canceling medium.

Secured to cap *e'* is a pawl or detent, L, that prevents retrograde rotation of driving-shaft E. This pawl or click is maintained in contact with gear-wheel *f'* by a spring, *l*, as seen in Fig. 3.

The segmental arbor *e* of the driving-shaft is housed within a lock-case, M, whose inner plate is pierced with an opening, *m*, of relatively-less diameter than the opening *m'* of the outer plate of said lock-case, and one end of driving-shaft E is journaled in the aperture *m*, as seen in Fig. 9. Fitted in this lock-case is a two-throw bolt, N, which is maintained in either one of its various positions by a tumbler, *n*, said tumbler being lifted, and the bolt thrown, by the insertion of a suitable key in the hole *n'*. This bolt is pierced with an opening, O, that is fully as large in diameter as opening *m'* of the lock-case. Communicating with this opening O is a slot, O', whose width is slightly less than the diameter of aperture *m'*. Slot O' terminates with a socket, O'', of such shape as to slip readily over the segmental arbor *e* of driving-shaft E, and thus prevent rotation of the latter. (See Fig. 12.) Rotation of this shaft is effected when a ballot is deposited by means of a crank, P, having a barrel, Q, of such diameter as to readily enter both of the openings *m'* and O. Said barrel is grooved circumferentially, thereby producing a neck, *q*, with which neck the slot O' of bolt N engages, as seen in Figs. 5 and 9. Furthermore, barrel Q is provided with a socket, *p*, of such shape as to receive the segmental arbor *e* of shaft E. R is a spring provided with stop *r* to maintain crank P in its proper normal position.

Pinion *e'* of driving-shaft E engages with a striking-wheel, S, having studs or pins *s* to operate the helve *t* of hammer T, which hammer is projected against bell or gong *t'* by means of a spring, *t''*.

Studs *s* are arranged on the wheel S so as to insure but a single blow of the hammer T upon bell *t'* at every complete revolution of pinion *e'*.

Striking-wheel S communicates motion to a train of clock-work, U, in such a manner as to cause a long hand, V, and a short hand, W, to rotate in front of their respective fixed dials or faces X Y, as seen in Fig. 1. These dials are located at the front end of the box, and may be housed within a glass case, so as to be visible to the bystanders, and yet not capable of being tampered with. The inner dial Y may be provided with but a comparatively limited set of consecutive numerals on its face—say from 1 to 25—while the outer concentric dial X may be numbered consecutively from 1 to 100.

The object of short hand W is to indicate

how many times the long hand V has traveled around its face X, and thus show at a glance how many hundred tickets have been deposited in the box. It is evident, however, that the clock-work U may be arranged so as to impart any desired ratio of rotation between the pointers V W.

Z Z' represent pillar-plates, within which are journaled the various shafts of the clock-work.

Our ballot-box is operated in the following manner: Hands V W are first set at the zero-mark of their respective dials X Y, and the door B is securely locked. Barrel Q of crank P is then passed through opening *m'* of the lock-case, and also through the aperture O of bolt N, thereby engaging the segmental arbor *e* of driving-shaft E with socket *p* of said crank-barrel. Now, by referring to Fig. 13, it will be seen that the peculiar shape of said arbor and socket causes crank P to assume a vertical position, thus bringing its left edge in contact with stop *r*, as seen in Fig. 6. A proper key is then inserted in key-hole *n'*, and the bolt N is thrown far enough to cause the slot O' to embrace the neck *q* of crank-barrel, after which act said key is withdrawn from lock-case M. Roller K is then charged with ink of any suitable kind or color, and the apparatus is at once ready to receive the ballots.

When the first ticket is inserted in the receiving-slot *c* the advancing end of the ballot passes directly into the cavity between the two rollers F H, and the custodian of the box then presses spring R back far enough to disengage crank P from stop *r*. This crank is then caused to make an entire revolution in the direction indicated by the arrows in Figs. 1 and 3, and, after completing the circuit, said crank is again arrested by the stop *r*. During this revolution of the crank the following movements take place in the box: Roller F, by its rotation with shaft E, draws the ticket into box A, and, as said roller imparts an opposite revolution to roller H, the result is that the types I print upon the ballot the previously-described inscription.

As soon as these oppositely-rotating rollers have made one complete revolution the ballot is securely deposited in the box, and this deposit is audibly announced to the bystanders by the hammer T striking one blow upon bell *t'*. This single blow upon the bell is caused by pinion *e'* rotating wheel S so far as to bring one of its pins *s* in contact with helve *t*, which act withdraws hammer T from the gong. As soon, however, as the helve escapes from said pin, the stress of spring *t''* throws the hammer back against the bell, and thus produces the single signal.

Simultaneously with this audible notice of a ballot having been cast the long hand V moves from the zero-mark or dial X to number 1 on said dial, thus affording an additional and visible proof of the vote having been deposited in the box. The deposit of the second

ballot is proceeded with in a precisely similar manner, the ticket being first canceled, the bell struck, and the hand V then moved from 1 to 2 on the dial X, and the above-described operations are repeated for every ticket that enters the box, with this exception, that said hand is advanced one numeral with each and every vote cast. As soon as this long hand has made one complete revolution around its dial X, thereby indicating the deposit of one hundred ballots, the short hand W moves from the zero-mark on its dial Y to 1, and this movement of the short hand is repeated at every revolution of the long hand. It is therefore evident that by having a sufficient number of numerals on these two dials the box will accurately register as many tickets as can be conveniently polled in a single day. While the ballots are being fed into the box the engagement of slot O' with barrel-neck q allows free rotation of driving-shaft E, but prevents crank P Q being detached from the box, and the detent L l prevents any retrograde rotation of said shaft E.

When the polls are closed the appropriate key is again applied to hole *n'*, and bolt N retracted so as to bring opening O in line with aperture *m'*, and thereby permit disengagement of crank P Q from arbor *e*. Bolt N is now thrown twice, so as to engage its socket O'' with the segmental arbor *e* of driving-shaft E, thereby locking the latter so as to prevent it being tampered with in any manner. (See Fig. 12.)

The key is now withdrawn from hole *n'*, and at the proper time door B is opened and the count proceeded with.

As it is impossible for a single genuine ticket to be inserted in the box without first being canceled with the printing devices and then announced both with the bell and pointers V W, it is apparent the number of canceled ballots in the box must agree exactly with the reading of dials X and Y. The only way to stuff this ballot-box would be to fold two or more tickets together and then insert them all at once in the slot *c*; but this artifice would prove of no avail, because but one of the tickets could be canceled, and, consequently, the uncanceled ones would be thrown out as spurious.

The same result would ensue in case a voter

should unintentionally fold up two or more tickets together, as the outer one only would be canceled.

It will thus be seen that our box insures a fair count at all times, and effectually prevents the casting of illegal ballots, either intentionally or by accident.

An inferior modification of the box may be made by omitting the indicating devices V W, X Y; but we prefer using them, because they furnish an additional safeguard against fraud.

We are aware that it is not new to apply a gong or bell to ballot-boxes for the purpose of giving audible notice of the deposit of tickets; and, therefore, our claim to the bell is limited to the combination of devices herein described, whereby the gong is operated through the instrumentality of a driving-shaft whose roller feeds the tickets into the box with a positive movement.

We claim as our invention—

1. The combination, with a ballot-box, of a gong or bell for giving audible notice of the deposit of each ticket, said gong or bell being operated by means of the driving-shaft that forces the ticket into the box with a positive movement, substantially as herein described and for the purpose set forth.

2. A ballot-box having combined with it suitable devices for canceling each ticket and announcing each deposit audibly with a bell, and visibly with indicators and dials, substantially as herein described, and for the purpose set forth.

3. In combination with pinion *e'* of driving-shaft E of a ballot-box, the striking-wheel S s, for operating the annunciator T t t' t'' at the deposit of each ticket in the box, substantially as herein described, and for the purpose set forth.

4. In combination with driving-shaft E *e*, lock M *m m'*, and socketed crank P *p, Q q*, the two-throw bolt N O O' O'', for locking said shaft and crank, substantially as herein described, and for the purpose set forth.

In testimony of which invention we hereunto set our hands.

JACOB FRICKER, JR.
ADOLPH SEINECKE.

Witnesses:

JAMES LAYMAN,
D. O. KENNEDY.