

S. & W. KATZ.

CAPS.

No. 193,875.

Patented Aug. 7, 1877.

Fig. 1

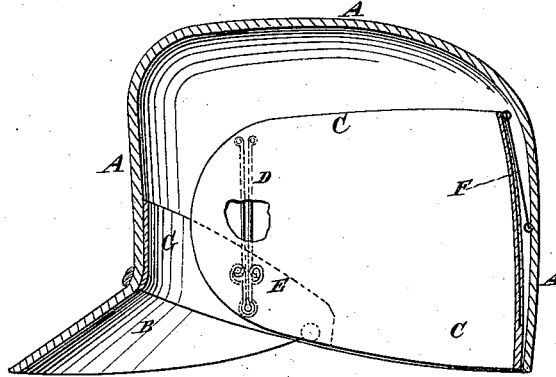

Fig. 2

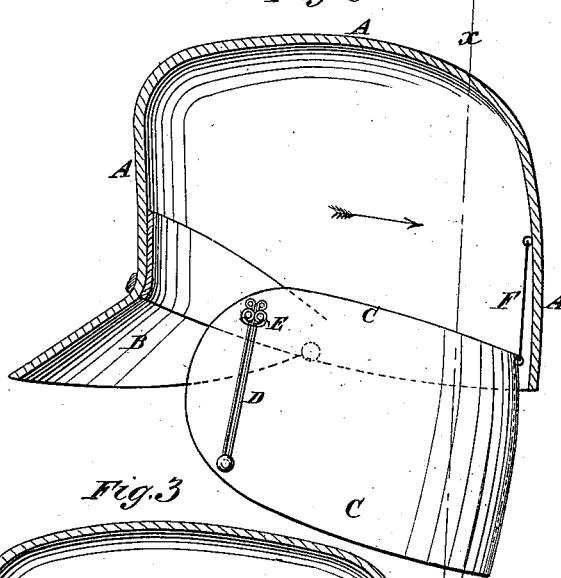
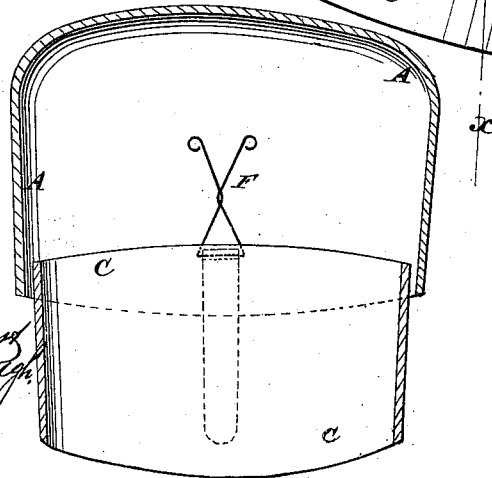

Fig. 3



WITNESSES:

*A. W. Monquist*  
*J. H. Scarborough*

INVENTOR, S.

*S. Katz*  
BY *W. Katz*  
*Mumford Co*

ATTORNEYS.

# UNITED STATES PATENT OFFICE.

SOLOMON KATZ AND WILLIAM KATZ, OF NEW YORK, N. Y.

## IMPROVEMENT IN CAPS.

Specification forming part of Letters Patent No. 193,875, dated August 7, 1877; application filed July 9, 1877.

*To all whom it may concern:*

Be it known that we, SOLOMON KATZ and WILLIAM KATZ, of the city, county, and State of New York, have invented a new and useful Improvement in Caps, of which the following is a specification:

Figure 1 is a vertical longitudinal section of our improved cap. Fig. 2 is a vertical longitudinal section of the outer part, the inner part being shown in side view. Fig. 3 is a vertical section of the same taken through the line *x x*, Fig. 2.

Similar letters of reference indicate corresponding parts.

The object of this invention is to furnish caps provided with inner sliding bands, which shall be so constructed that they may be lowered to cover and protect the back part of the head and neck, and may be raised within the cap, when not required for use, so as to be entirely out of sight and out of the way, and which shall not increase the thickness of the cap materially, or make it appear heavy or clumsy.

The invention will first be described in connection with the drawing, and then pointed out in the claim.

In the drawing, A is the body and B is the front piece of the cap, which are made of the usual materials, and in the usual way. C is an open band, of such a length that its end parts may cover the ears of the wearer, and of such a width as to cover and protect the back of the head and neck. To the upper and lower edges of the outer sides of the ends of the band C are attached the ends of a slide,

D, made of wire or other suitable material, and which passes through a guide, E, attached to the inner part of the cap-body A, a little above its lower edge. To the upper edge of the rear part of the band C is hinged one end of a wire frame, F, the other end of which is hinged to the inner surface of the cap-body A, at a distance from its lower edge a little more than the length of the said frame F.

The open band C is lowered by sliding its ends downward, and, at the same time, moving the upper edge of its middle part inward and downward, so that the frame, bar, or rod F may turn upon its hinges.

The open band C is made of chamois leather, so as to be soft, light, thin, and warm, and its outer side may be faced with cloth or some other suitable material.

The forward part of the cap-body A is provided with a chamois sweat-leather, G, which is made of such a length that its ends may be overlapped by the ends of the band C.

Having thus fully described our invention, we claim as new and desire to secure by Letters Patent—

The combination, with body A, of the band C, the slide D, the guide-eye E, and the frame F, all constructed and arranged as and for the purpose specified.

SOLOMON KATZ.  
WILLIAM KATZ.

Witnesses:

JAMES T. GRAHAM,  
C. SEDGWICK.