

2 Sheets—Sheet 1.  
M. BROWN, F. J. McFARLAND & J. BROWN.  
CHURNS MADE OF BENT WOOD.

No. 193,918.

Patented Aug. 7, 1877.

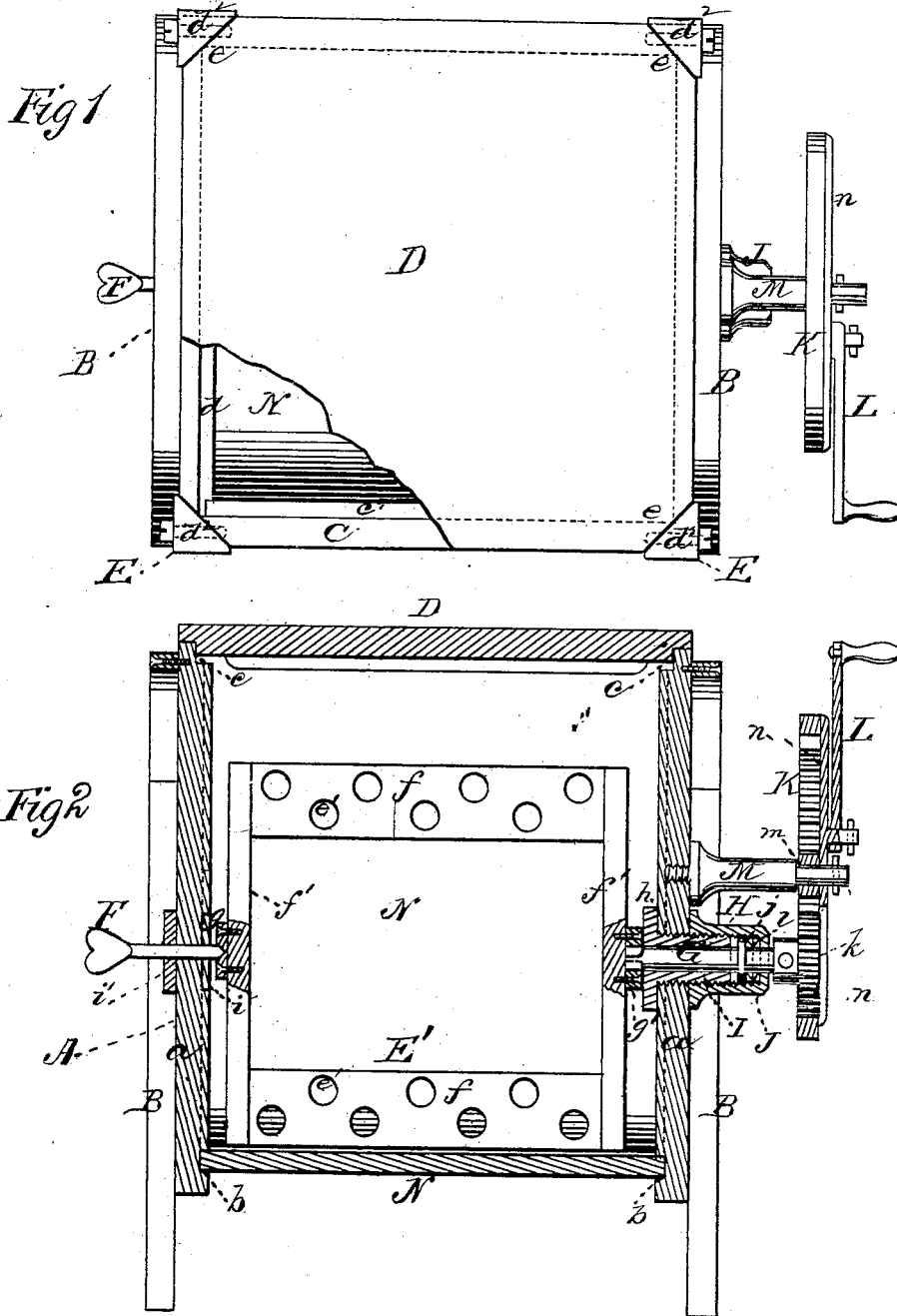

WITNESSES  
*Villette Anderson*  
*A. J. Davis*

INVENTORS  
Michael Brown  
F. J. McFarland  
Joseph Brown  
by *Edw. Anderson*  
ATTORNEY

M. BROWN, F. J. McFARLAND & J. BROWN.

CHURNS MADE OF BENT WOOD.

No. 193,918

Patented Aug. 7, 1877.

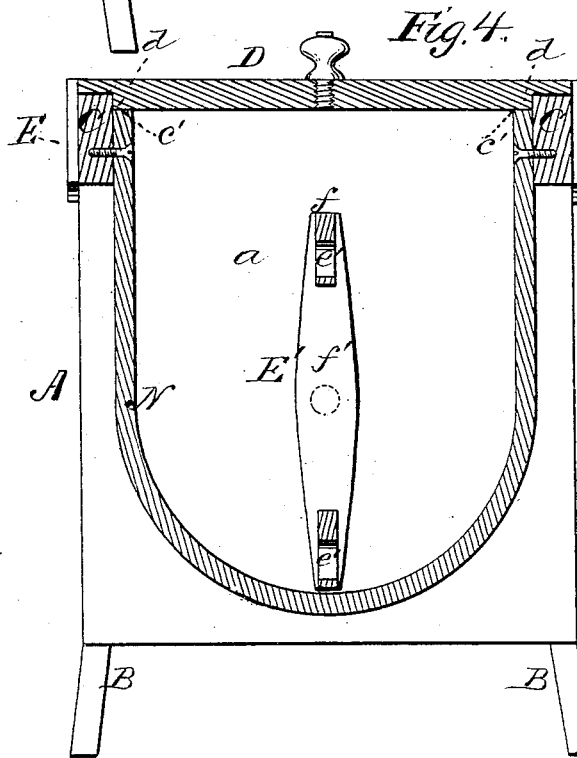
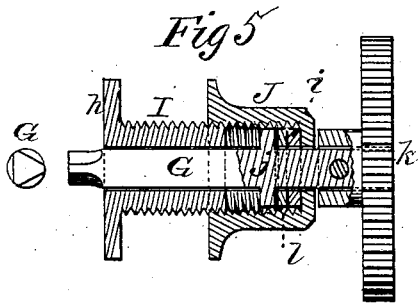
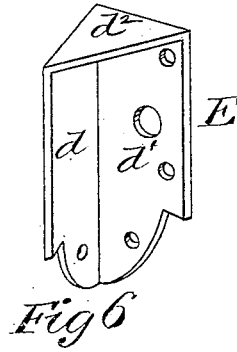
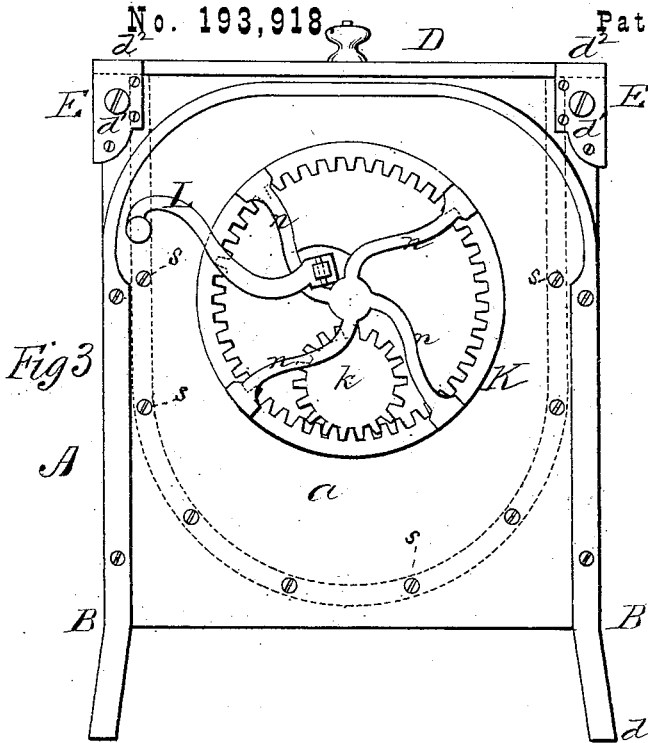

WITNESSES  
*Villette Anderson*  
*F. J. Masi*

INVENTORS  
 Michael Brown,  
 F. J. McFarland,  
 Joseph Brown,  
 by *E. W. Anderson,*  
 ATTORNEY

# UNITED STATES PATENT OFFICE.

MICHAEL BROWN, FRANCIS J. McFARLAND, AND JOSEPH BROWN, OF  
WAPAKONETTA, OHIO.

## IMPROVEMENT IN CHURNS MADE OF BENT WOOD.

Specification forming part of Letters Patent No. **193,918**, dated August 7, 1877; application filed  
June 30, 1877.

*To all whom it may concern:*

Be it known that we, MICHAEL BROWN, FRANCIS J. McFARLAND, and JOSEPH BROWN, of Wapakonetta, in the State of Ohio, have invented a new and valuable Improvement in Bent-Wood Churns; and do hereby declare that the following is a full, clear, and exact description of the construction and operation of the same, reference being had to the annexed drawings, making a part of this specification, and to the letters and figures of reference marked thereon.

Figure 1 of the drawings is a representation of a top view of our improved churn. Fig. 2 is a longitudinal central vertical section thereof. Fig. 3 is an end view of the same. Fig. 4 is a vertical section, and Figs. 5 and 6 are details.

This invention has for its object the improvement of churns having rotary dashers.

The nature of the invention consists in certain novel means of forming the box, whereby the latter is made of three pieces only; in the novel construction of an improved packing, whereby the leaking of cream through the joint of the dasher-spindle and box is effectually prevented; in the employment of angular metallic corner-plates for holding the end pieces and the sides and bottom piece in proper juxtaposition; and in the novel arrangement and construction of the various devices employed, as will be hereinafter more fully set forth.

In the annexed drawings, the letter A designates the box of our improved churn, and B the legs upon which it is supported. The former is composed of two end pieces, *a*, of suitable material, preferably ash wood, and the latter of a single piece of board of sufficient width, bent into the form of the letter U, and let into grooves *b*, of corresponding shape, formed in the said end pieces. The bottom and side piece and the ends are then rigidly secured together by means of screws *s* passing through the latter into the edges of the former. The end pieces at their upper edges are rabbeted, as shown at *c*, and a corresponding rabbet is formed at *c'* on the corresponding edges of the sides by means of a bracing-strip, C, which is bolted to the outside thereof, as shown in Fig. 4. The rabbets *c c'* form a seat for

the lid D, which is correspondingly rabbeted, as shown at *d*. In order to prevent all tendency to springing which the natural elasticity of the bent sides and bottom piece might cause, we employ strong metallic angle-plates E, rigidly secured by means of bolts and screws to each upper corner of the box. These plates, as shown in perspective, Fig. 6, are composed of two side wings, *d d'*, and of a top plate, *d''*, connecting the former. When in position the wings *d d'* embrace the side and end pieces, and the plate *d''* lies snugly upon the upper edge of the box and bracing strip; consequently the corners of the lid are cut off, as shown at *e*, in order that it may be applied. The angle-plate wing *d''* is thus converted into a stop which effectually prevents the lid from being removed or displaced except by an upward movement; in other words, it cannot be tilted off. The legs B, before alluded to, are also formed by bending a strip of wood in U form, and bolting or screwing the said strip to the extensions of the ends *a* in an inverted position. The dasher E' is composed of a rectangular frame, having spaced perforations *e'* in its paddles *f*. Its end arms *f'* are provided the one with a metallic plate, *g*, having a conical recess, and a like plate, *g'*, provided with a prismatic recess, adapted, respectively, to receive a conical-ended adjusting spindle-screw, F, and a spindle, G, having a prismatic end. The screw passes through an inside and an outside screw-threaded plate, *i i'*, and the spindle through a packing device, H, of the following description: It consists primarily of a tubular bearing, I, having a prismatic head, *h*, and screw-threaded upon its exterior surface. This bearing is screwed from within into the end wall of the box, and projects sufficiently to allow of the application thereto of an exterior screw-cap, J. The spindle G projects through this cap, and is provided with an inside collar, *j*, and an exterior gear-wheel, *k*, and upon this spindle outside of the said collar are applied one or more packing-rings, *l*, which, the cap being properly screwed up, will be forced by the collar against the inside of the end wall of the cap, and cause the spindle to form an absolutely tight joint with the spindle. By un-

screwing the adjusting-screw F the dasher may be removed from the box, even though the latter be half full. In practice we may use a suitable locking device for the purpose of preventing the spindle-screw from rotating backward and allowing the dasher to become unshipped. Rotary motion is imparted to the dasher through an annular master-gear, K, meshing with gear *k* upon the projecting end of the spindle G, and a suitable crank, L, rigidly but removably secured to the said master-gear near its hub. This wheel is connected with a hub, *m*, by means of radial arms or spokes *n*, that unite with the perimeter of said wheel outside of and clear from its inside cogged surface, and is journaled on an independent axis or spindle, M, projecting from the box. To get at the packing for renewal, take off the master and gear wheels, remove the dasher, and unscrew the cap. The spindle G may then be taken out of its bearing and the packing removed and others substituted.

What we claim as new, and desire to secure by Letters Patent, is—

1. The combination, with the end pieces *a*

and the side and bottom pieces N, formed as described, of the corner angle-plates E, having the upper wing  $d^2$  raised above the sides and ends of said box, and serving as stops for its lid, substantially as specified

2. The combination, with churn-body A, of the packing device consisting of the tubular bearing I, having prismatic collar *h*, and exteriorly screw-threaded, the screw-cap J, the spindle G, provided with collar *j*, and the packing-rings *l*, substantially as specified.

3. The combination, with the journal G of a churn-dasher having collar *j* and the tubular outside-threaded bearing I, of the compression screw-cap J and the packing-rings *l*, substantially as specified.

In testimony that we claim the above we have hereunto subscribed our names in the presence of two witnesses.

MICHAEL BROWN.  
FRANCIS J. MCFARLAND.  
JOSEPH BROWN.

Witnesses:

F. C. LAYTON,  
C. P. DAVIS.