

J. MEGAW.
 ROLL-GRINDING MACHINES.

No. 193,984.

Patented Aug. 7, 1877.

Fig. 2.

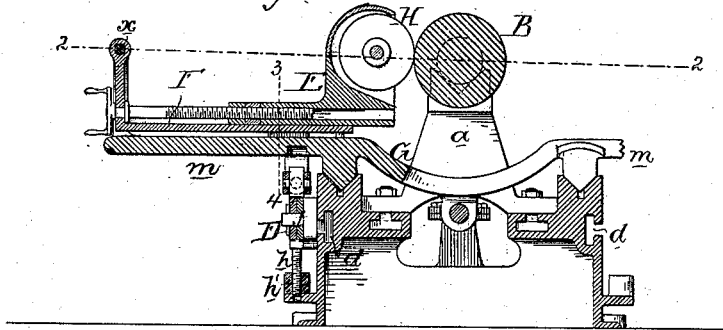

Fig. 1.

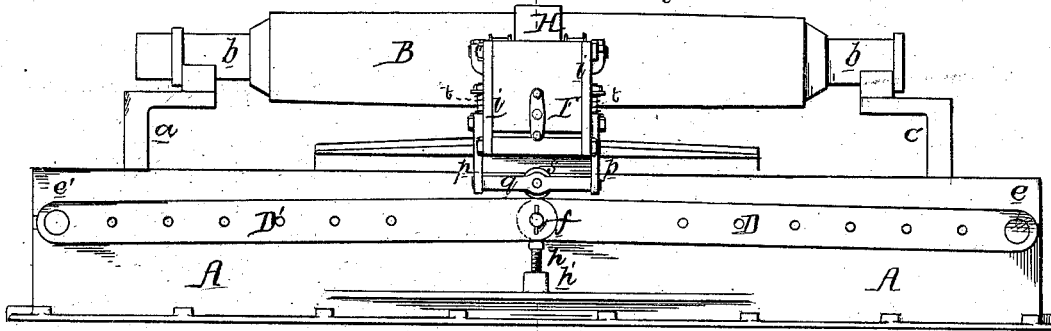

Fig. 3.

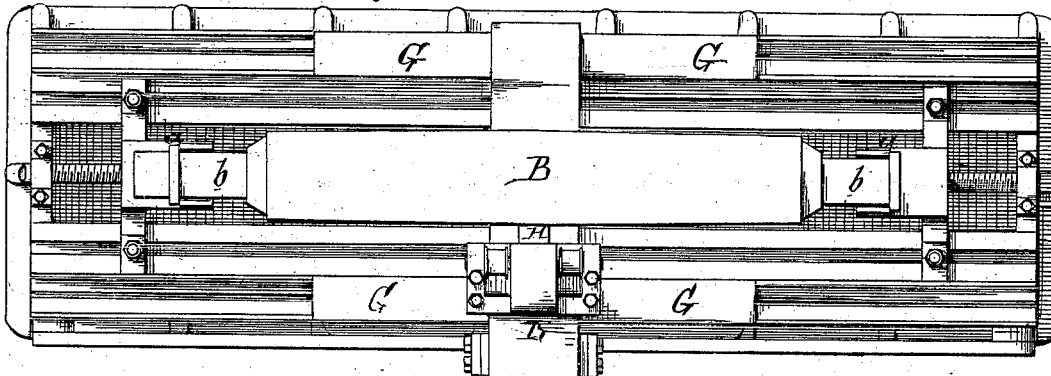

Fig. 4.

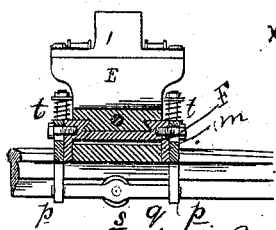

Fig. 5.

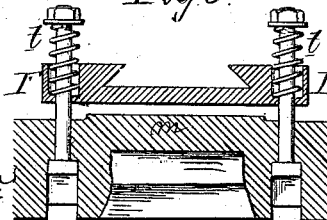
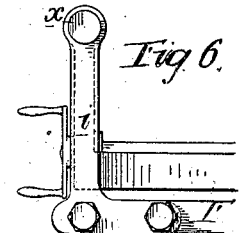

Fig. 6.



Witnesses

John M. Deegan
 Harry Smith

Inventor
 Jamett Megaw
 by his Attorneys
 Howson and Co.

UNITED STATES PATENT OFFICE.

JARRETT MEGAW, OF PHILADELPHIA, PA., ASSIGNOR OF ONE-HALF HIS
RIGHT TO LOBDELL CAR WHEEL COMPANY, OF WILMINGTON, DEL.

IMPROVEMENT IN ROLL-GRINDING MACHINES.

Specification forming part of Letters Patent No. 193,984, dated August 7, 1877; application filed
February 26, 1877.

To all whom it may concern:

Be it known that I, JARRETT MEGAW, of Philadelphia, Pennsylvania, have invented a new and useful Improvement in Machines for Grinding Rolls, of which the following is a specification:

My invention relates to machinery for grinding and polishing chilled rolls; and the object of my invention is to provide a machine of this class with appliances whereby a roll may be reduced to a greater degree in the middle than at the ends, or vice versa, and whereby different degrees of taper from the middle to the ends may be imparted to different rolls.

In the accompanying drawing, Figure 1 is a front view of the roll-grinding machine; Fig. 2, a vertical section on the line 1 2; Fig. 3, a plan view; Fig. 4, a vertical section on the line 3 4; Fig. 5, an enlarged view of part of Fig. 4; and Fig. 6, an enlarged view of part of the machine.

A is the base of the machine, having bearings *a a*, to which are adapted the journals *b b* of the chilled roller B. A T or V shaped groove, *d*, in the base-plate extends from end to end of the same, and to this groove are adapted two sliding studs, *e e'*, Fig. 1, and to the stud *e* is hinged a bar, D, a similar bar, D', being hinged to the stud *e'*, and the two bars being hinged together by a rule-joint, *f*, immediately beneath which is a set-screw, *h*, adapted to a stud, *h'*, which can slide along a projection on the frame. By means of this screw the bars D and D' can be adjusted to different inclinations, and it is these bars which control the position of the grinding-wheel H in respect to the axis of the roll, in a manner which I will now proceed to describe. This wheel has its bearings in a slide, E, adapted to guides on a plate, F, on which the slide can be traversed to and fro by a screw or other device. This plate F is hinged at *x* to two standards, *i i*, secured to opposite edges of a projection, *m*, on the main slide or carriage G, on the under side of which are two V-shaped ribs, adapted to similarly-shaped guides on the base A, a screw or other mechanism being used as a means of traversing the carriage to and fro on the base.

The plate F, which carries the slide E and

its grinding-wheel, is supported partly by the pin of the hinge *x*, and partly by the rods D D', which control the movement of the said plate on its hinge, and therefore control the position of the grinding-wheel as the carriage G is traversed along the base of the machine.

The support of the hinged plate by the bars D D' is, in the present instance, effected through the medium of hangers *p p*, secured to opposite edges of the plate, and a carrier, *q*, and a roller, *s*, which bears on the upper edges of the bars, and which is arranged to turn freely in the carrier, the latter being free to vibrate in the hangers, so that the roller will accommodate itself to the edges of the bars, no matter what may be their position.

The hangers *p p* are preferably made vertically adjustable on the plate F, for obvious reasons.

The hinged plate F should be combined with appliances which always tend to depress that end which carries the wheel, and to cause the roller *s* to bear on the edges of the bars D D' under all circumstances, thereby insuring the steady maintenance of the grinding-wheel in the vertical position determined by the bars. In order to effect this, I prefer to use coiled springs *t*, surrounding bolts which pass through the projection *m* of the carriage, and through the plate F, which is depressed by the springs, the latter being confined between the plate and the heads of the bolts.

In the present instance the controlling-bars D D' have been raised in the middle by the adjusting-screw *h*, and the rapidly-revolving grinding-wheel H is acting on the slowly-revolving chilled roll, at a point midway, or thereabout, between its opposite ends.

The center of the grinding-wheel is above a line, 2 2, Fig. 2, drawn through the center of the hinge *x*, and through that of the chilled roll; but, as the grinding-wheel is traversed with the carriage G in either direction, the center of the grinding-wheel must, owing to the inclination of the controlling-bars, gradually move downward in the arc of a circle, of which the hinge *x* is the center, and the periphery of the wheel must at the same time move toward the axis of the chilled roll, and the latter must, consequently, be reduced in diameter as the

wheel is moved longitudinally toward either end of the roll; hence, when the roll is finished from end to end, it must have the largest diameter in the middle, and have the proper taper from the middle to the opposite ends.

If the bars D and D' are so adjusted that they are lowest at the hinge *f*, the grinding-wheel would so reduce the roll that it would be of smaller diameter in the middle than at the ends. In both cases the degree of difference between the diameter of the roll at the middle and the ends of the same will depend upon the degree of inclination of the controlling-bars.

A controlling-bar in one piece, and having two inclined planes, may be used when a number of rolls of precisely similar character are required; but, for general use I prefer the two bars hinged together. The location of the pivots *e e'* and the situation of the hinge *f* longitudinally, however, may be varied, as the length and position of the rolls may suggest.

It may be remarked that the position of the hinge *x* and that of the upper edges of the controlling-bars should be such in respect to each other and to the grinding-wheel that in finishing the roll the center of the grinding-wheel should never be below the line 2 2', drawn through the center of the said hinge and that of the roll.

Although I have shown but one grinding-wheel, I prefer to use two, operating on opposite sides of the roll simultaneously, both wheels being on the same carriage G, and combined with appliances described above.

I claim as my invention—

1. The combination, in a roll-grinding machine, of a carriage, to be traversed on the base of the machine, a plate pivoted to the said carriage, and carrying the grinding-wheel, two inclined planes on the base and mechanism, substantially as described, whereby the planes are made to control the said pivoted plate and grinding-wheel, all substantially as set forth.
2. The combination, in a roll-grinding machine, of adjustable bars D D', hinged together at *f*, with the hinged plate F carrying the grinding-wheel and the carriage G.
3. The combination of the hinged plate F and bars D D', and the roller *s*, made self-accommodating to the edges of the said bars, substantially as described.

In testimony whereof I have signed my name to this specification in the presence of two subscribing witnesses.

JARRETT MEGAW.

Witnesses:

HERMANN MOESSNER,
HARRY SMITH.