

T. H. SAVERY.
 ROLL-GROUNDING AND FINISHING-MACHINE.
 No. 194,001. Patented Aug. 7, 1877.

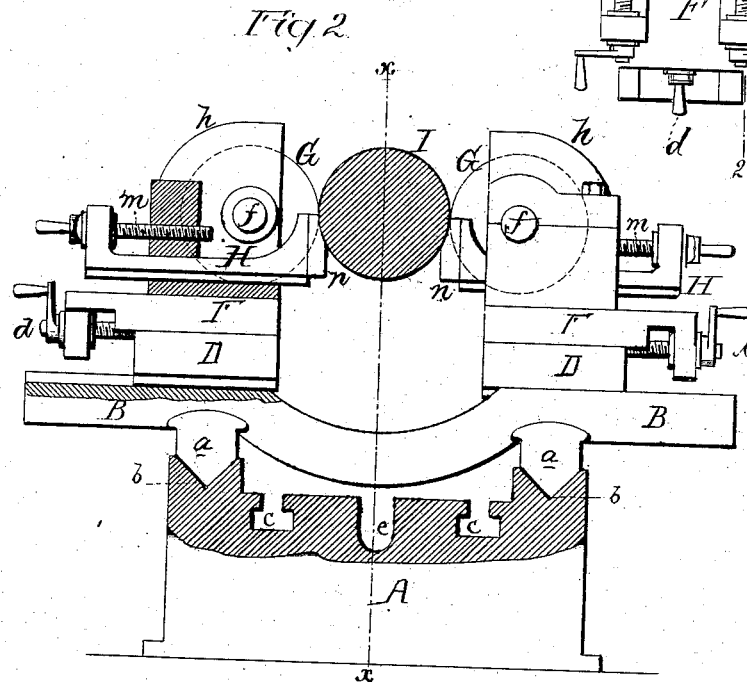

Witnesses
 Harry A. Crawford
 Harry Smith

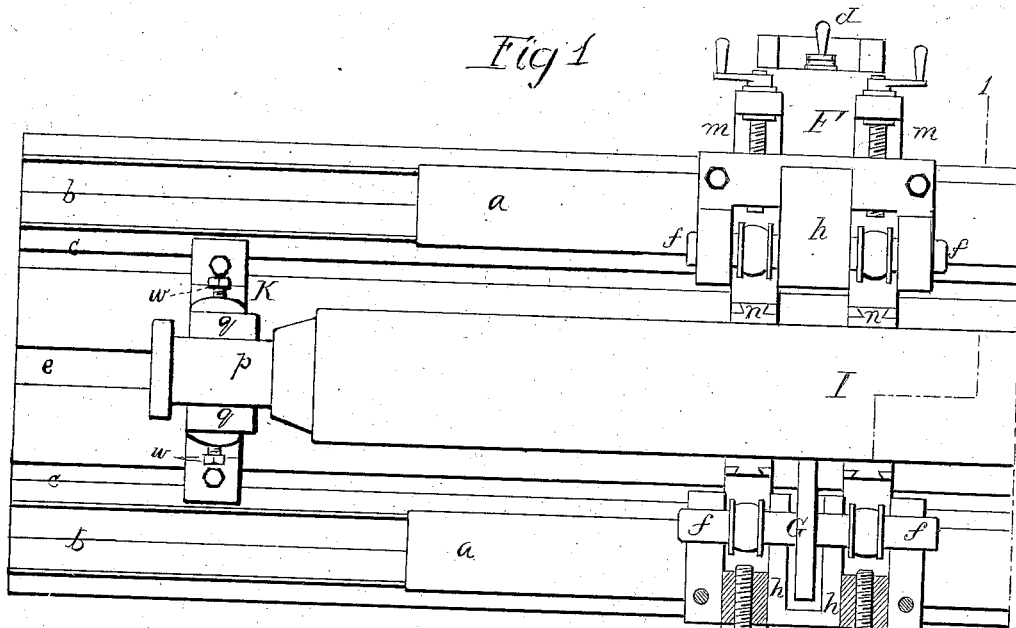
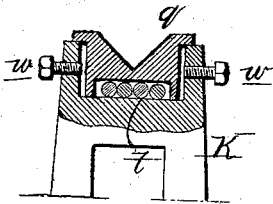

Inventor
 Thomas H. Savery
 by his Attorneys
 Howson & Co.

UNITED STATES PATENT OFFICE.

THOMAS H. SAVERY, OF WILMINGTON, DELAWARE, ASSIGNOR TO HIMSELF,
J. L. PUSEY, AND W. G. GIBBONS, AND THE LOBDELL CAR WHEEL
COMPANY, OF SAME PLACE.

IMPROVEMENT IN ROLL GRINDING AND FINISHING MACHINES.

Specification forming part of Letters Patent No. 194,001, dated August 7, 1877; application filed
June 12, 1877.

To all whom it may concern:

Be it known that I, THOMAS H. SAVERY, of Wilmington, Delaware, have invented a new and useful Improvement in Roll Grinding and Finishing Machines, of which the following is a specification:

My invention consists of mechanism, too fully described hereinafter to need preliminary explanation, for truly grinding or finishing chilled rolls and other like objects.

In the accompanying drawing, Figure 1 is a plan view, partly in section, of my improved roll grinding and finishing machine; Fig. 2, a transverse section on the line 1 2, and Fig. 3 a sectional view of one of the bearings of the roll to be ground.

A is the base of the machine, to V-shaped grooves *b* on which are adapted corresponding ribs *a* on the carriage B, which can be traversed to and fro on the bed by a screw or any of the mechanical appliances used for actuating the traversing slide-rest of a lathe or the table of a planing-machine.

To guides on the opposite ends of the carriage are adapted the bases D D, one on each side of the central line *x*, Fig. 2, the bases being adjustable from and toward the said central line, and being combined with appliances by which they may be secured after adjustment.

Each base D carries a slide, F, controlled by a screw, *d*, by manipulating which the said slide can be moved from or toward the aforesaid line *x*. Each slide has bearings for the spindle *f* of a grinding or polishing wheel, G, to which a rotating motion is imparted from any adjacent shaft, and which is partly inclosed by a hood, *h*, secured to the slide.

Two bars, H H, pass through and are guided by each slide F, one on each side of the wheel G, each bar being controlled by an adjusting-screw, *m*. The inner end of each bar is provided with a bearing-block, *n*, of any suitable material.

To the journals *p* of the roll are adapted bearing-blocks *q*, each block being contained within a recess in the top of the standard K, secured to the bed A, after adjustment thereon to a proper position, determined by the said journals of the roll.

Each bearing-block *q* is capable of moving in the recess of the standard to an extent determined by the set-screws *w w*.

In order to allow each bearing-block to move freely, I prefer to interpose between it and the bottom of the recess rollers *t*, as shown.

It should be understood that the above machine is for grinding and finishing rolls or other objects which have been previously turned.

After the roll I has been placed in its bearing, the slides F are so adjusted that the opposite grinding-wheels shall have the desired bearing against the said roll, after which two or more of the sliding bars are so adjusted that their bearing-blocks *n* shall be in contact with the roll, the latter being then slowly rotated, and the carriage B traversed along the bed of the machine, while a rapid and rotary motion is imparted to the grinding-wheels.

Being confined between the bearing-blocks, the roll must yield laterally, should there be any untruth in the course of the carriage; in other words, if the carriage pursues a course out of parallel with the roll, the latter must obey the carriage, and must yield accordingly, which it is at liberty to do owing to its free bearings; hence the amount of metal removed by the grinding-wheels from the roll is not determined by the course of the carriage B, but by the roll itself, which, in obedience to the bearings *n n*, will not permit the removal of any metal from its surface which is not in accordance with the truth of the roll.

It will be seen that the lateral yielding of the roll is accomplished through the medium of the bearings *n n*, and that neither of the grinding-wheels has more duty to perform when the yielding of the roll takes place than when the bearings of the roll are stationary.

The importance of this arrangement will be understood by supposing the bearings *n n* to be absent, in which case the lateral yielding of the roll must be accomplished through the medium of one or other of the grinding-wheels, a plan which must necessarily induce the untrue grinding of the roll.

The bearing-blocks *n n*, moreover, permit me to use fine cutting-tools, when I desire to

employ them in place of the grinding-wheels, for the bearings must restrict the tools to their proper duties.

It is important that the bearings *n n* should be adjustable independently of the grinding-wheels, so that the said bearings may always be in close contact with the roll, and may be adjusted in accordance with the reduction of the same.

I claim as my invention—

1. In a machine for grinding or finishing rolls and other like objects, the combination of free bearings for the roll, traversing grinding-

wheels or other tools, and bearing-blocks *n n*, adapted to the roll, all substantially as set forth.

2. The combination of the carriage B and the adjustable slides F, carrying the grinding-wheels or other tools, with bearing-blocks *n n*, which admit of being adjusted independently of the said slides.

In testimony whereof I have signed my name to this specification in the presence of two subscribing witnesses.

Witnesses: THOS. H. SAVERY.

F. F. SLOCOMB,

JAMES M. WATSON.