

E. SCHLUETER.
SWINGS.

No. 194,003.

Patented Aug. 7, 1877.

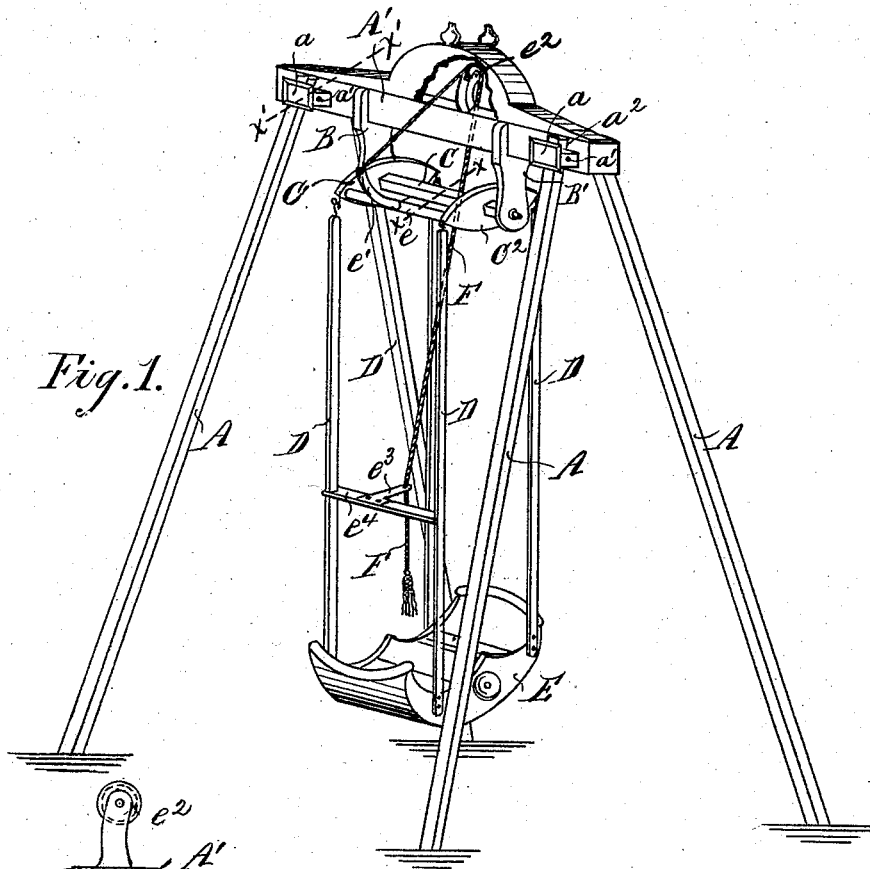

Fig. 1.

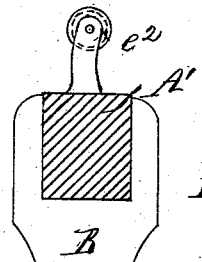

Fig. 2.

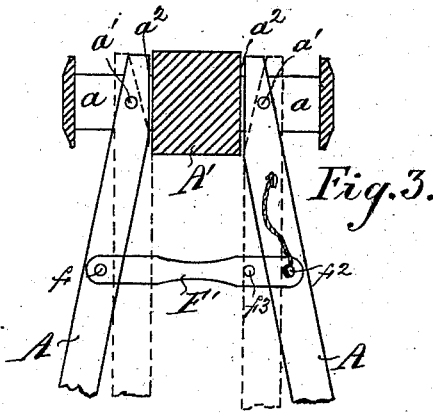
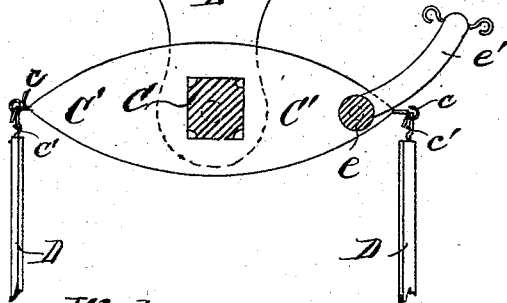

Fig. 3.

Witnesses;
J. W. Hestel.
Chas. Hestel

Inventor,
Ernst Schlueter
per
Hestel & Co.

UNITED STATES PATENT OFFICE.

ERNST SCHLUETER, OF ST. LOUIS, MISSOURI.

IMPROVEMENT IN SWINGS.

Specification forming part of Letters Patent No. 194,003, dated August 7, 1877; application filed May 23, 1877.

To all whom it may concern:

Be it known that I, ERNST SCHLUETER, of St. Louis, in the county of St. Louis and State of Missouri, have invented an Improved Parlor-Swing, of which the following is a specification:

This invention relates to certain improved features in the construction of swings, as will hereinafter be pointed out in the claims.

Of the drawings, Figure 1 is perspective view of my improved swing as ready for use. Fig. 2 is a sectional elevation on line xx of Fig. 1, showing the chief parts from which the seat is suspended, Fig. 3 being a sectional elevation on line $x'x'$, showing the joint of the legs to the cross-piece.

A are the legs; A', the upper or cross bar. From this, by means of the hangers B B', the swing parts are suspended, as will hereinafter appear. The joining of the legs at the top to the cross-bar is done in the following manner: There is secured permanently to the cross-bar A', near each end, a block bearing, the projecting ends a of which are slotted to receive the upper ends of the legs, the latter being pivoted thereto at a^1 , (see Figs. 1 and 3,) the object of so pivoting the legs at their top ends being to enable them to be spread out the required distance to assume a safe bearing inclination for the swing proper; also, to enable the user to fold them close together, and thus facilitate the handling, transporting, and use of the swing parts. Further, each leg at a^2 has a bevel, (see Figs. 1 and 3,) so as to allow the top end of each leg to bear against the side of the cross-bar A' and insure a firm bearing for each leg. The adjustability of the legs pivoted to bearing-blocks is shown more clearly in Fig. 3.

The full lines indicate that the legs are spread out below and bear against the cross-bar at the top, while the dotted lines show that the legs can be folded together.

The axle C oscillates in the hangers B B'. The journals of the axle are round, so as to turn on the smallest bearing, but the body part of the axle is made square, to more rigidly secure thereto the bow-shaped blocks C¹ C². (See Figs. 1 and 2.) In each end of the

bows C¹ C² are secured eyes c , in which the hooks c' of each of the four inflexible hangers D D D are suspended. (See Figs. 1 and 2.) To the lower end of each of said hangers is secured rigidly the seat E. (See Fig. 1.) Thus suspended to operate the seat E, the bows C¹ C² are united by a cross-piece, e , and to this is secured the curved arm e' , to which one end of the cord F is secured. (See Figs. 1 and 2.) The cord is next passed over a roller, e^2 , top of the cross-bar, (see Figs. 1 and 2,) from thence the cord passes down through a center-arm, e^3 , which is secured to a cross-piece, e^4 , and this to two of the hangers. (See Fig. 1.) By means of the arm e^3 the cord can be brought and kept in the center and within ready reach.

The slightest reciprocation of the cord oscillates the seat, and the swinging can be most easily continued, owing to the bows C¹ C² and the arm e^1 affording great leverage, and the axle turning on a small bearing.

As is apparent, the swinging can be done without passing the cord over the top roller; also, the arm e^4 can be dispensed with; but I prefer the construction and arrangement of the parts as above described and shown in the drawing.

F' is a band-bar, pivoted at f to one of the legs. The opposite end of the bar has one or more holes, f^3 , through which a coupling-pin, f^2 , passes to secure said bar to the opposite leg, the purpose of the device F' being to more permanently secure the legs steady when spread apart.

What I claim is—

1. The legs A, having a bevel at a^2 , and being pivoted at a^1 to bearing-blocks, the latter being slotted at a , said parts being combined with a cross-bar A', to operate in the manner and for the purpose set forth.

2. An improved swing consisting of the legs A, jointed, as shown, to the cross-bar A', hangers B B', axle C, bows C¹ C², hangers D D D, seat E, said parts being combined with a cord attachment, to operate in the manner set forth.

3. The center-arm e^3 , its cross-piece e^4 , in combination with hangers D D, and cord F,

axle C, hangers B B', cross-bar A', legs A, and seat E, as and for the purpose set forth.

4. The combination of the cross-bar A', legs A, bearing-blocks *a*, hangers B B', axle C, bows C¹ C², cross-piece *e*, arm *e*¹, hangers D D D D, seat E, and cord attachment to form the improved swing, substantially as set forth.

In testimony of said invention I have hereunto set my hand.

ERNST SCHLUETER.

Witnesses:

GEORGE SCHMIDT,
WILLIAM W. HERTHEL.