

T. A. WESTON.
HOISTING-TACKLE.

No. 194,019.

Patented Aug. 7, 1877.

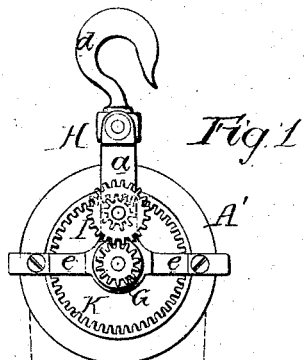

Fig. 2.

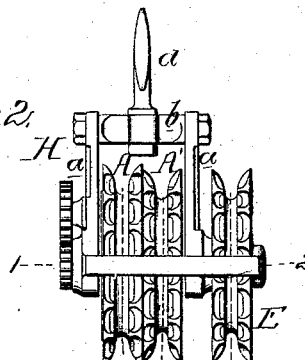
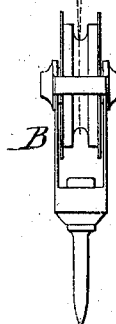
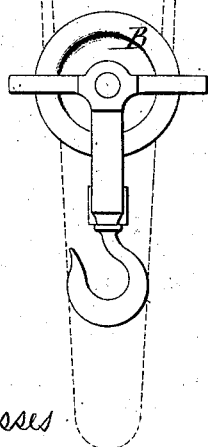
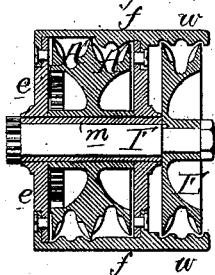

Fig. 3.



Witnesses

Henry Howson Jr.
Henry Smith

Inventor
Thomas A. Weston
by his Attorneys.
Howson and son

T. A. WESTON.
HOISTING-TACKLE.

No. 194,019.

Patented Aug. 7, 1877.

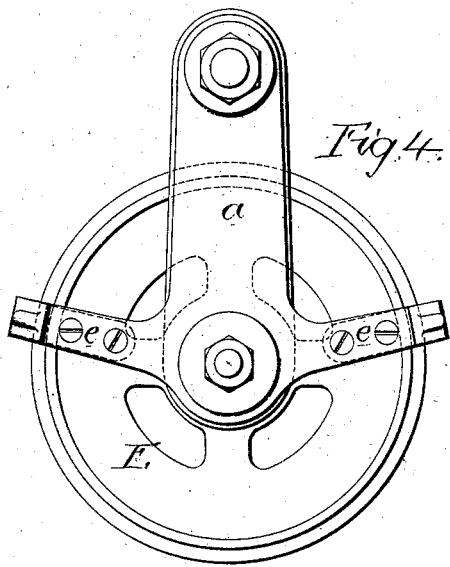

Fig. 4. Fig. 5.

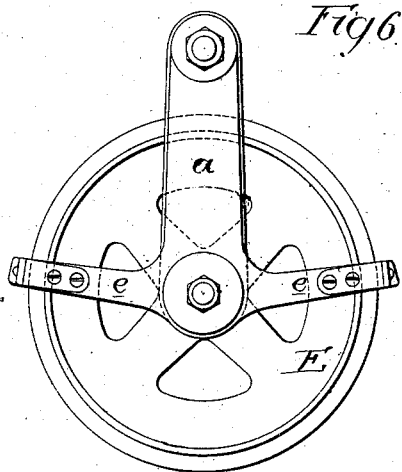
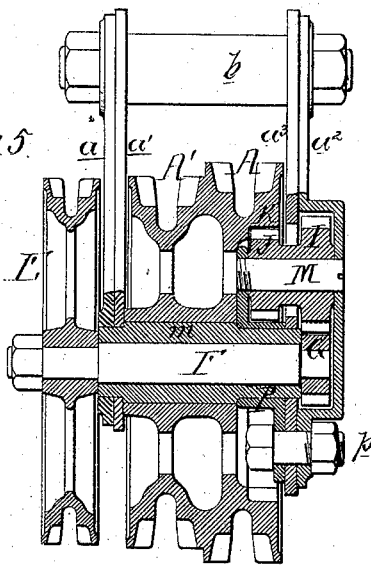
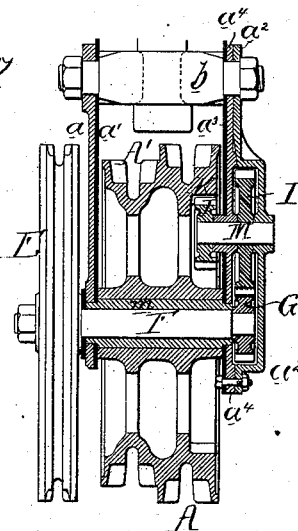

Fig. 6.

Fig. 7.



Witnesses
Henry Howson Jr.
Harry Smith

Inventor
Thomas A. Weston
by his Attorneys
Howson and son

UNITED STATES PATENT OFFICE.

THOMAS A. WESTON, OF STAMFORD, CONNECTICUT, ASSIGNOR TO THE
YALE LOCK MANUFACTURING COMPANY, OF SAME PLACE.

IMPROVEMENT IN HOISTING-TACKLE.

Specification forming part of Letters Patent No. **194,019**, dated August 7, 1877; application filed
April 18, 1877.

To all whom it may concern:

Be it known that I, THOMAS A. WESTON, of Stamford, Connecticut, have invented a new and useful Improvement in Hoisting-Tackle, of which the following is a specification:

The object of my invention is to combine pulley-blocks with simple gearing, through the medium of which the capacity of said blocks for raising heavy weights shall be increased without materially increasing the weight or bulk of the blocks.

In the accompanying drawings, Figure 1 is a side view, and Fig. 2 an edge view, illustrating the application of my invention to the differential pulley-blocks for which Letters Patent were granted to me on the 6th day of August, 1867; reissued July 9, 1872; Fig. 3, a sectional plan on the line 1 2, Fig. 2; Figs. 4 and 5, a side view and section of the differential block, drawn to an enlarged scale, and illustrating my invention; and Figs. 6 and 7, a side view and section with modified attachments for the gearing.

It should be understood in the outset that, although I have illustrated and am about to describe my invention as applied to my patented pulley-blocks, to which it is especially well adapted, the system of gearing can be used in connection with ordinary blocks and hoisting-tackle.

In Figs. 1, 2, and 3, A and A' represent the differential pulleys, carried by a frame consisting of the pendent arms *a a*, a cross-bar, *b*, to which the hook *d* is swiveled, horizontal arms *e e*, forming part of the pendent arms, and guards *f f*, secured to the said horizontal arms.

The lower pulley-block B is of the usual construction, and the hoisting-chain, the course of which is shown by dotted lines, is arranged in a manner precisely similar to that described in my aforesaid patent, in which the said hoisting-chain was manipulated in raising and lowering weights.

In my present improvement I use an additional endless chain, D, to be manipulated by the operator, this chain being adapted to a pulley, E, on a shaft, F, which has its bear-

ings in the frame H, passes through and turns independently of the differential pulleys, and is provided at the end opposite to that which carries the driving-pulley E with a pinion, G, the teeth of which gear into those of a wheel, I, on a short counter-shaft, M, which has its bearing in one of the pendent arms *a* of the frame H, this shaft having a pinion, J, the teeth of which gear into those of an internal wheel, K, formed within the rim of the largest of the two differential pulleys A A'.

It will be evident that, in operating the differential pulleys by the endless chain D and chain-wheel E through the medium of the gearing described, such an increased leverage is obtained that the capacity of the blocks for raising heavy weights at a comparatively trifling exercise of power is increased, and this without much additional expense, and without rendering the blocks as cumbrous as they become when the other systems of gearing which have been heretofore invented are made use of.

While the shaft may pass directly through the eyes of the differential pulleys, and turn in contact therewith, it is preferable in all cases to have an intervening sleeve, *m*.

As regards the detailed construction of the block, it may be varied without departing from the main feature of the invention.

In Figs. 4 and 5, Sheet 2, one of the pendent arms consists of a plate, *a*, and link *a*¹, and the other of the plate *a*² and link *a*³; and the sleeve *m*, on which the differential pulleys revolve, is secured at one end to the plate *a* and link *a*¹, and at the other end to the link *a*³, the plate *a*², adjacent to this link, being bent to the form of a yoke to accommodate the gearing, and the lower end of this plate being secured to a continuation of the link *a*³, and also to a plate, P, which is fitted to the sleeve, and to the upper end of which is secured the counter-shaft M, the latter being stationary in this modification of my invention, and its outer end being supported by the plate *a*².

The wheel I, which is driven by the pinion G on the driving-shaft F, and the pinion J, which gears into the internal wheel of the dif-

ferential pulley, are made in one piece, and revolve together on the stationary counter-shaft.

In the modification shown in Figs. 6 and 7 there is, in addition to the link a^3 and the yoke-plate a^2 , an intermediate plate, a^4 , which forms one of the bearings for the counter-shaft M, which, in the present instance, is arranged to revolve, and the outer bearing of which is in the yoke-plate a^2 .

There is one feature common to all modifications of my invention, and that is the continuation w of the guards for the chain of the differential pulleys, so as to form a guard for the endless driving-chain. This guard for the driving-pulley may, however, be attached to any part of the frame H of the pulley-block.

It will be readily seen without description that an independent endless driving chain and pulley, with the system of gearing which I have described, may be combined with an ordinary pulley-block.

I claim as my invention—

1. The combination, in a pulley-block, of a hoisting pulley or pulleys, a driving-shaft passing through the hoisting pulley or pulleys, a driving-pulley secured to the said shaft, and the system of cog-wheels having fixed central axes, substantially as described, whereby the said driving-shaft is geared to the said hoisting pulley or pulleys, as herein set forth.

2. The combination, in a differential pulley-block, of the differential pulleys, of different diameters, and rigidly secured to each other,

a driving-shaft passing through the same, a driving-pulley secured to said shaft, and a system of gearing, substantially as described, whereby the said driving-shaft is geared to the said differential pulleys.

3. An improved pulley-block containing the following elements, viz: a hoisting pulley or pulleys, a driving pulley and shaft, and a system of cog-wheels for communicating motion from the driving-pulley to the hoisting-pulley, all the said cog-wheels having fixed central axes radially within the circumference of the hoisting-pulley, substantially as described.

4. In a pulley-block, the combination of a hoisting pulley or pulleys, provided with toothed gearing, with the driving-pinion G and pinions I J, radially within the circumference of the said pulley, as set forth.

5. The combination, in a pulley-block, of the hoisting pulley or pulleys, the driving-shaft F, and the intermediate sleeve m , on which the said pulley or pulleys turn, as described.

6. The plate P, fitted to and combined with the sleeve m , and secured to the block-frame, and forming a support for one end of the fixed counter-shaft M.

In testimony whereof I have signed my name to this specification in the presence of two subscribing witnesses.

THOMAS A. WESTON.

Witnesses:

MERMANN MOESSNER,
HARRY SMITH.