



D. B. REYNOLDS.

COMBINED CANE AND CAMP-STOOL.

No. 194,175.

Patented Aug. 14, 1877.

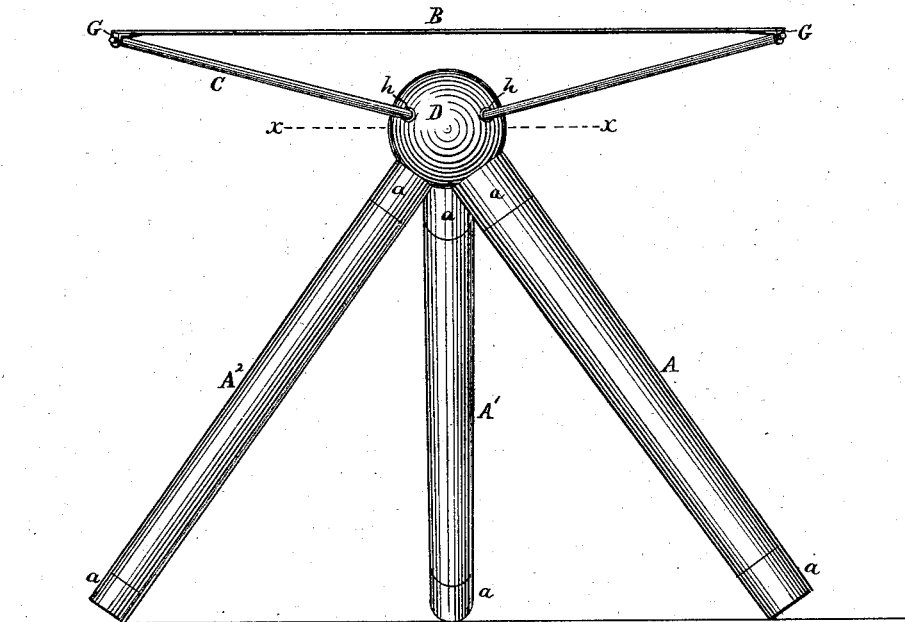

FIG. 12.

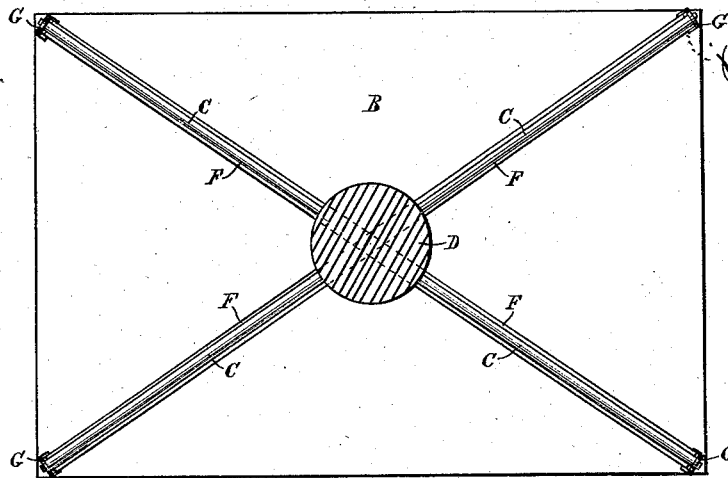

FIG. 13.

WITNESSES.

*N. G. Lombard*  
*E. A. Hemmeway*

INVENTOR.

*Darius B. Reynolds*

# UNITED STATES PATENT OFFICE.

DAVIS B. REYNOLDS, OF BROCKTON, MASSACHUSETTS, ASSIGNOR OF ONE-HALF HIS RIGHT TO WALTER L. FRENCH, OF SAME PLACE.

## IMPROVEMENT IN COMBINED CANE AND CAMP-STOOL.

Specification forming part of Letters Patent No. 194,175, dated August 14, 1877; application filed July 12, 1877.

### *To all whom it may concern:*

Be it known that I, DAVIS B. REYNOLDS, of Brockton, in the county of Plymouth and State of Massachusetts, have invented a new and useful Improvement in Combined Cane and Camp-Stool, of which the following, taken in connection with the accompanying drawings, is a specification.

My invention relates to the construction of a cane or walking-stick that may be readily converted into a stool or seat.

It consists, first, in forming the cane of three sections of equal lengths, and each equal to about one-third the whole length of the desired cane, said sections being connected together by suitable joints or couplings, in combination with a head provided with suitable means of securing each of said sections of the body of the cane thereto, so as to form therefrom a tripod, upon which may be erected a seat by the use of certain other devices supplied with the cane, as will be described.

My invention further consists in making the body of the cane in three sections of equal lengths, jointed or coupled together end to end, in combination with a removable head, provided with suitable sockets to receive the detachable sections of the cane-body to form a tripod, and other sockets to receive three or more arms to support a cloth seat stretched thereon.

My invention further consists in making the body of a cane in three sections of equal lengths, coupled together end to end, and adapted to be each coupled to the cane-head to form a tripod, in combination with three or more rods or arms adapted to be secured in sockets in the cane-head, and rise therefrom in an inclined direction, and a flexible seat, provided with suitable metal sockets to engage with the outer ends of said rods or arms.

My invention further consists in forming, in one or more of the sections of the body of the cane, a chamber, in which may be packed the cloth seat and the supporting-arms, one or both, when not desired for use in the construction of a stool.

My invention further consists in the use of a special means of coupling the several sections of the body of the cane together or to

the cane-head, which will be best understood by referring to the description of the drawings hereinafter given.

Figure 1 of the drawings is an elevation of the cane complete. Fig. 2 is a central longitudinal section of the upper section of the cane and the cane-head, illustrating the manner of packing the cloth seat and its supporting-arms. Fig. 3 is a plan of the cane-head detached, and shown in the same position it occupies when the cane is converted into a camp-stool. Figs. 4 and 5 are, respectively, an end view and a central longitudinal section of the female portion of the coupling detached. Figs. 6, 7, and 8 are, respectively, an end view, a side elevation, and an edge view of the male portion of the coupling detached. Figs. 9, 10, and 11 are, respectively, a plan, a side elevation, and an end view of the metal socket to be attached to the canvas seat. Fig. 12 is a side elevation of a camp-stool constructed from the cane and its contents. Fig. 13 is a horizontal section on line *xx* on Fig. 12, and showing an inverted plan of the cloth seat and its supporting-arms.

A, A<sup>1</sup>, and A<sup>2</sup> are three sections of the body of the cane, made of wood or other suitable light material, and of suitable size and shape, and each provided with a metal ferrule, *a*, at each end thereof, to strengthen the same against fracture. The upper section A has formed within it the chamber *b*, to receive the cloth seat B and the supporting rods or arms C C, as shown in Fig. 2.

D is the cane-head, made in the form of a ball or sphere, with a short cylinder, *c*, projecting from one side thereof, said cylinder being made to fit into and close up the upper end of the chamber *b*, and serving as a means of attaching the head to the cane, and also of securing one of the legs of the tripod in the formation of the seat or camp-stool.

The lower ends of sections A and A<sup>1</sup> have inserted therein a hollow cylindrical bushing, *d*, provided at its outer end with the inwardly-projecting lips *e*, as shown in Figs. 4 and 5.

In the upper ends of the sections A<sup>1</sup> and A<sup>2</sup> are set the coupling studs or shanks *f f*, made in the form shown in Figs. 6, 7, and 8, and having their smaller or cylindrical ends set

and firmly secured in said sections, with their shoulders *g g* distant from the end of said sections a distance just equal to the longitudinal thickness of the lips *e* of the bushings or sockets *d*, with which said shoulders engage when coupling the different sections together.

The openings between the lips *e* of the bushings *d* and the transverse section of the large end of the coupling-shanks *f f* are of the same shape and size, and the different sections are readily and securely coupled together by passing the enlarged end of each shank *f* through the opening in the outer end of the bushing *d* till the ends of the two sections come in contact with each other, and then turning one of said sections about one-quarter of a revolution around its axis, when the shoulders *g g* of the shank *f* engage with the lips *e e* of the bushing *d*, thus preventing separation of the two sections until one of said sections is again rotated to disengage the shoulders *g g* from the lips *e e*.

The cane-head *D* has set therein two of the bushings *d*, in the positions shown in Fig. 1, to receive the coupling studs or shanks *f f* in the upper ends of the sections *A*<sup>1</sup> and *A*<sup>2</sup>, when it is desired to convert the cane into a camp-stool.

The head *D* has also set therein the smaller metal bushings *h h*, three or four of which may be used, according to whether it is desired to use a square or rectangular seat-cloth or a triangular one, said bushings being inserted upon the side of the head opposite to the bushings *d d* and the cylindrical projection *c*, as shown.

Three or four light metal rods, *C C*, are provided, one end of each of which is to be inserted in one of the sockets *h h*, so as to radiate from the ball *D* in an upwardly-inclined direction when it is desired to convert the cane into a seat, as shown in Fig. 12. The outer ends of these rods *C C* are reduced in diameter so as to form shoulders *i i*, as shown in Fig. 2.

*B* is a rectangular piece of cloth, preferably canvas, provided with strengthening-stays *F*, made preferably of strong webbing stitched firmly to the under side of the canvas, and extending diagonally across the same from corner to corner, and having secured to the ends thereof the metal sockets *G G*, as shown in Fig. 13. The sockets *G* are each provided with a hole, *j*, of a size to fit the reduced end of one of the rods *C C*, and when placed thereon the inner face of said socket rests against the shoulder *i*, as shown in Fig. 13.

When the use of a seat is no longer required the canvas is removed and folded by turning in its two ends upon the middle portion, and it is then rolled around the rods *C C* as compact as may be, and the roll thus formed is placed within the chamber *b*, formed in the section *A* of the body of the cane, said

section having been previously removed from the cylindrical shank of the cane-head *D* to give access to said chamber, and the rods *C C* having also previously been removed from the sockets *h h* in the head *D*.

The section *A*<sup>1</sup> is next uncoupled from the head and coupled to the section *A*, and the section *A*<sup>2</sup> is in like manner uncoupled from the head and coupled to the section *A*<sup>1</sup>.

The cylindrical shank *c* of the head *D* is then inserted in the upper end of the chamber *b* of the section *A*, when the cane is again ready for use as such.

What I claim as new, and desire to secure by Letters Patent of the United States, is—

1. A cane provided with a head, and having its body made in three sections of about equal lengths, coupled together end to end, and adapted to be readily disconnected and coupled to the cane-head to form a tripod, substantially as and for the purposes described.

2. In combination with the body of a cane made in three sections of equal lengths, coupled together end to end, and adapted to be readily disconnected, a cane-head provided with means for coupling said sections thereto to form a tripod, and also provided with three or more sockets to receive radial arms to support a flexible seat, substantially as described.

3. The combination of the sections *A*, *A*<sup>1</sup>, and *A*<sup>2</sup>, adapted to be coupled together end to end to form a cane, and to the cane-head *D* to form a tripod, three or more arms, *C C*, adapted to be set in sockets in the head *D* in inclined radial positions, and provided with shoulders *i i* near their outer ends, and a flexible seat, *B*, provided with the metal sockets *G G*, adapted to engage with said shoulders *i i*, substantially as described.

4. A cane-body made in three sections of equal lengths, coupled together end to end, and adapted to be readily disconnected and coupled to the cane-head to form a tripod, in combination with the chamber *b*, formed in one of said sections, and adapted to receive the flexible seat and its supporting-arms, one or both, substantially as and for the purposes described.

5. As a means of coupling two or more sections of a cane-body together, or to the cane-head, the cylindrical socket or bushing *d*, provided with the lips *e e*, in combination with the shank *f*, provided with the shoulders *g g*, adapted to engage with the inner sides of the lips *e e*, substantially as and for the purposes described.

Executed at Boston, Massachusetts, this 7th day of July, A. D. 1877.

DAVIS B. REYNOLDS.

Witnesses:

N. C. LOMBARD,  
E. A. HEMMENWAY.