

J. C. CHAMBERS.  
 LIGHTNING-RODS AND INSULATORS.

No. 194,220.

Patented Aug. 14, 1877.

Fig. 1.

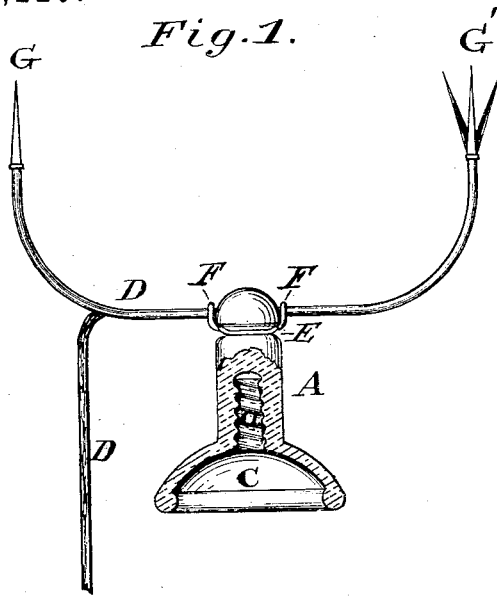

Fig. 2.

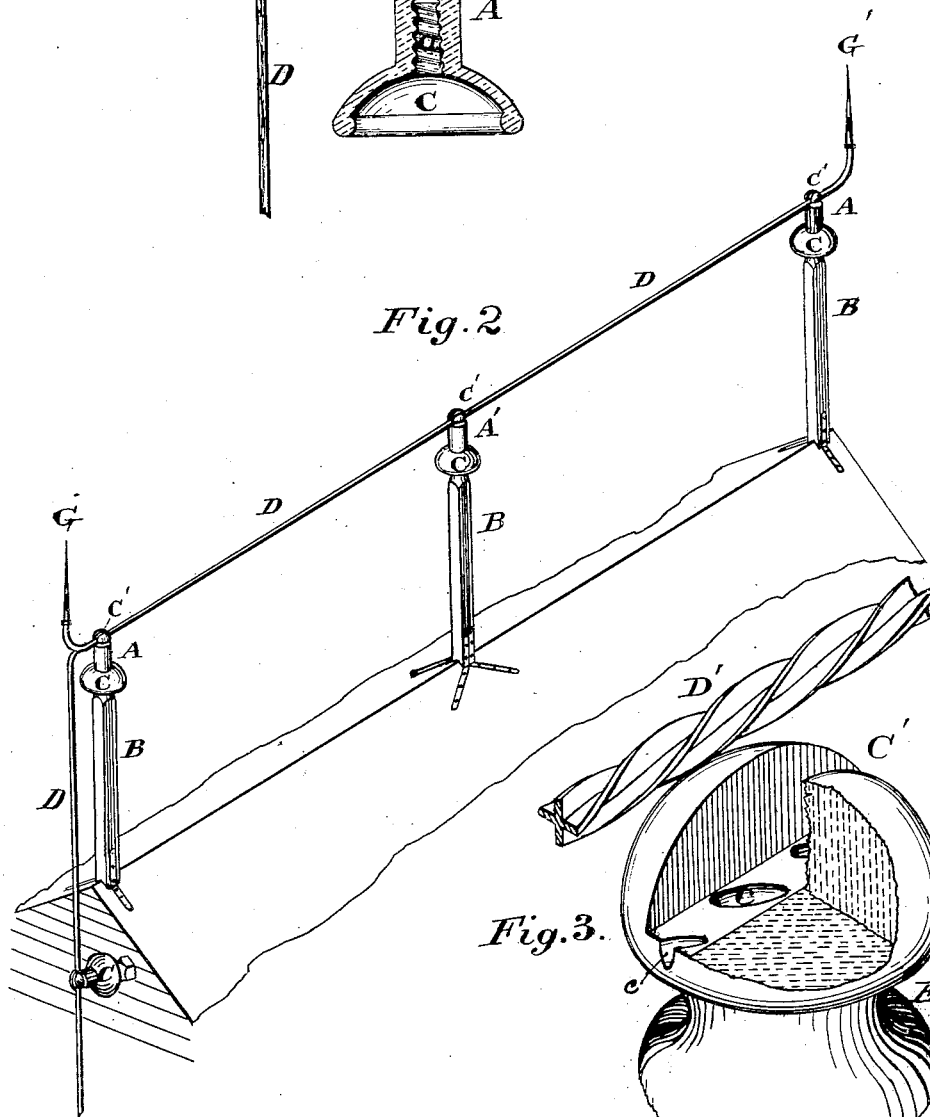
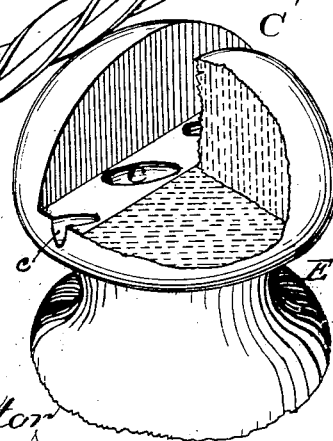

Fig. 3.



Attest  
 Walter Knight  
 S. F. Sturdivant

Inventor  
 Josephus C. Chambers  
 By Knight Bros. Atty.

# UNITED STATES PATENT OFFICE.

JOSEPHUS C. CHAMBERS, OF NEWPORT, KENTUCKY.

## IMPROVEMENT IN LIGHTNING-RODS AND INSULATORS.

Specification forming part of Letters Patent No. **194,220**, dated August 14, 1877; application filed May 29, 1877.

*To all whom it may concern:*

Be it known that I, JOSEPHUS C. CHAMBERS, of Newport, Campbell county, Kentucky, have invented a new and useful Improvement in Lightning-Rods and Insulators, of which the following is a specification:

My invention relates to a form of glass or other suitable insulator for lightning-rods and similar conductors.

In the accompanying drawings, Figure 1 is a partially-sectional elevation of a rod and insulator embodying my improvements. Fig. 2 is a perspective view, showing a series of the insulators supported by standards from the comb of a roof, and one for the attachment of the ground portion of the rod. Fig. 3 is a detailed view on a larger scale.

The insulator A is of glass, and may have the usual interior screw *a*, for attachment to a suitably screw-threaded stem or post, B. The said insulator expands at bottom into a shield, C, the flaring form of which adapts it to serve as a hood, preventing the electric current reaching the post B in a nearly vertical line, and has in its crown a notch, C', to receive and hold the rod D. Said insulator has also a circumferential groove, E, for the reception and retention of the wire F, where-with the rod is bound fast to the insulator.

For a spiral rod, such as D', Fig. 3, the bottom of the notch C' may have oblique indentations, as at *e*, to prevent the overturn or displacement of the rod by high winds or other causes; but I find in practice that the flanges of the spiral rod afford so secure a hold for the tying-wire that when said wire

is tightly applied the rod is firmly held against turning, even without the supplemental notches *e*.

In practice I place the points G G' at least six feet apart, and not less than six feet above the building. When both points are upon a single insulator, one of them may be multiple in form, as at G', Fig. 1.

I claim as new and of my invention—

1. The spiral rod constructed with a horizontal attaching portion and one or more up-turned receiving-points, in combination with the insulator constructed with a summit groove to receive the rod and a circumferential groove for the tying-wire to secure said rod in position, substantially as described.

2. The combination of the main groove C', for the reception of the rod, and the supplementary oblique grooves *e*, to receive the spiral flanges of the rod, and prevent it from turning.

3. A lightning-rod insulator constructed as herein shown, with a screw-socket for application to the post, an enlargement below the said screw-socket to prevent contact between the post and the neck of the insulator, and an umbrella-shaped flange expanding downward from the neck, serving to shed the rain and as a shield.

In testimony of which invention I hereunto set my hand.

JOSEPHUS C. CHAMBERS.

Attest:

GEO. H. KNIGHT,  
WALTER KNIGHT.