

W. T. ORR.
SULKY-PLOWS.

No. 194,258.

Patented Aug. 14, 1877.

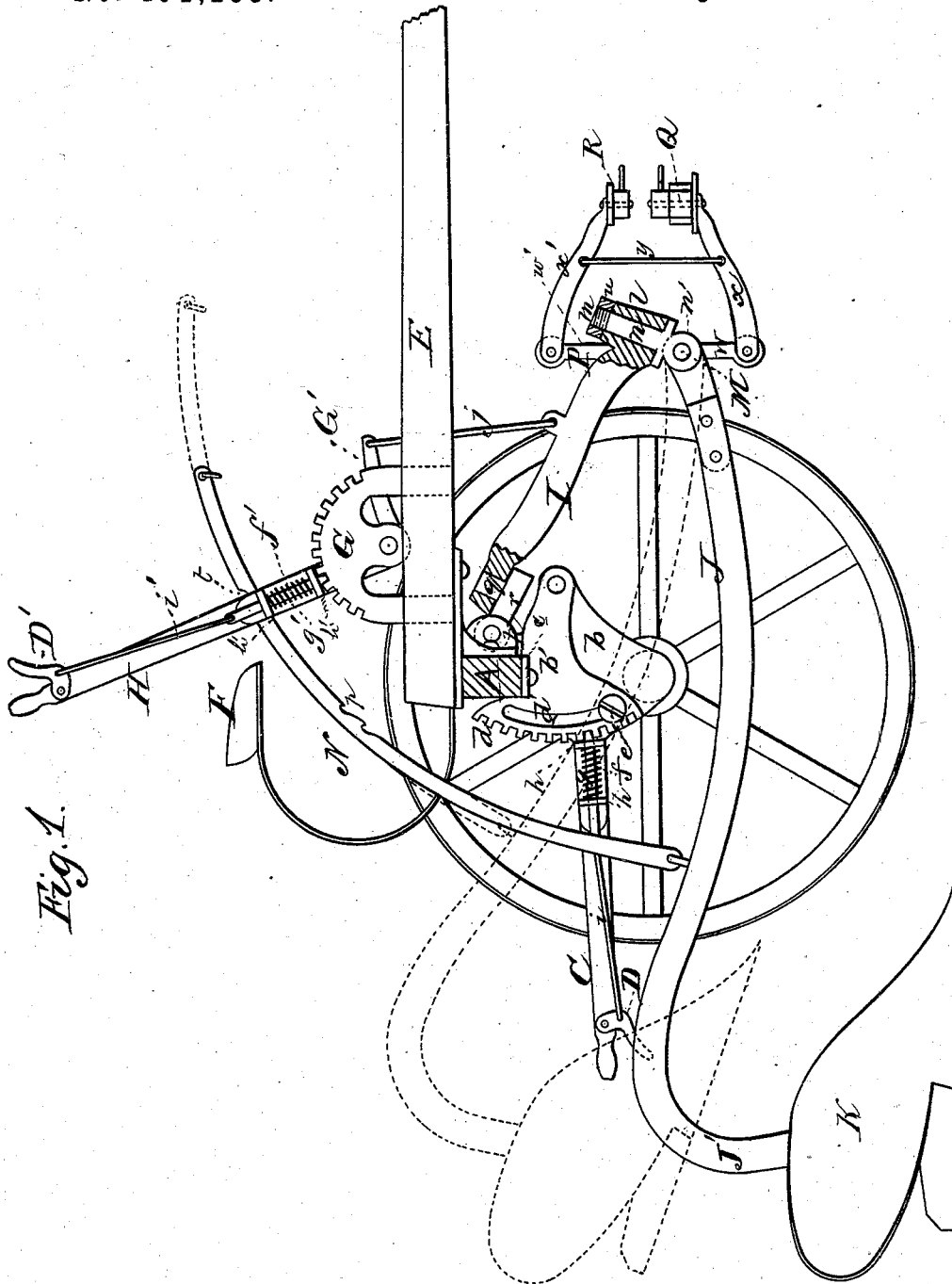

Fig. 1.

WITNESSES

Mo. P. Utley.
F. J. Cassill.

INVENTOR

William T. Orr,
by E. W. Anderson,

ATTORNEY.

W. T. ORR.
SULKY-PLOWS.

No. 194,258.

Patented Aug. 14, 1877.

Fig. 2.

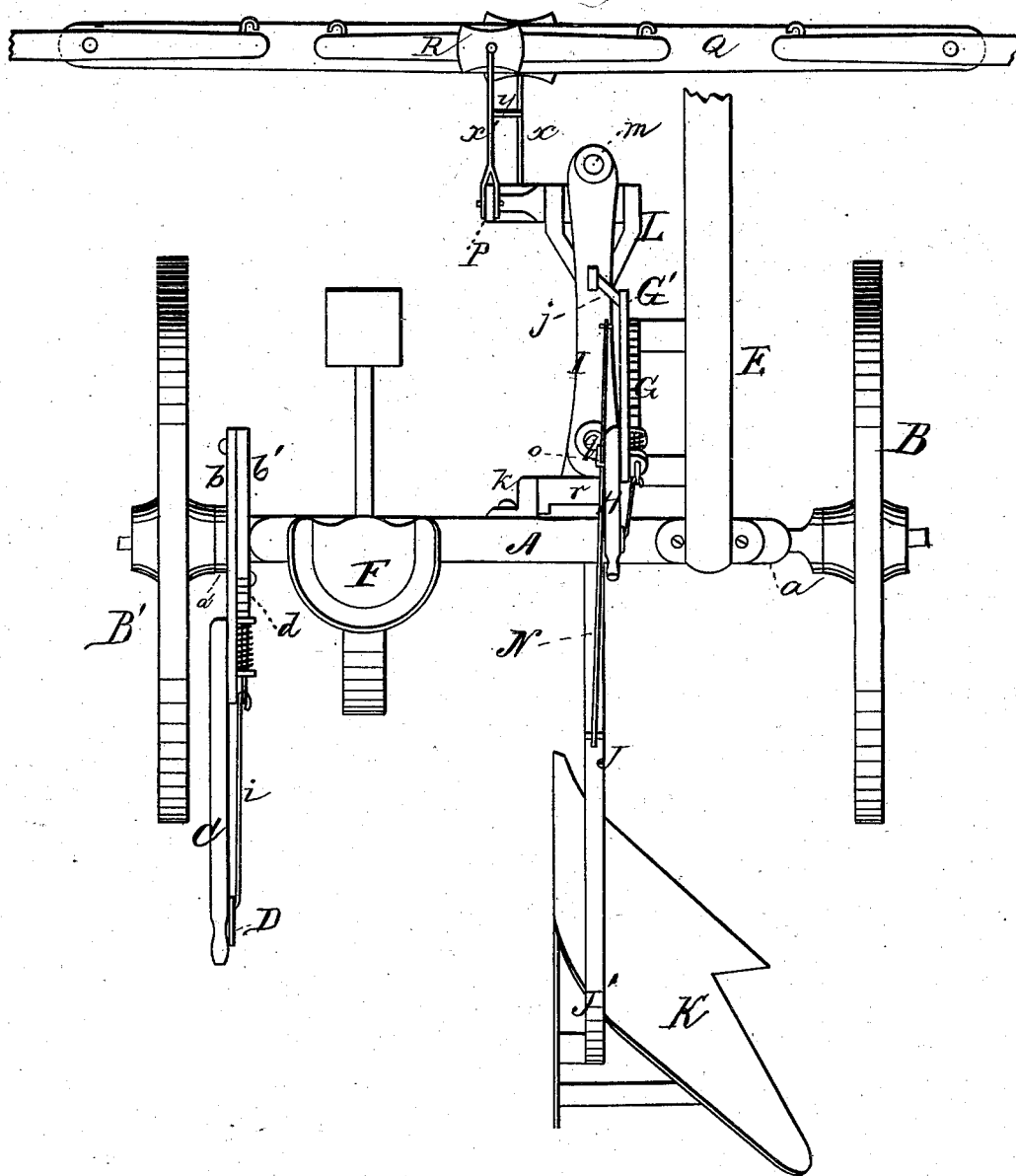

WITNESSES

Mo. S. Utley
A. Jellard

INVENTOR

William T. Orr,
by E. W. Anderson

ATTORNEY

UNITED STATES PATENT OFFICE.

WILLIAM T. ORR, OF KEWANEE, ILLINOIS, ASSIGNOR TO JOSEPH ORR, OF
SAME PLACE.

IMPROVEMENT IN SULKY-PLOWS.

Specification forming part of Letters Patent No. 194,258, dated August 14, 1877; application filed
December 2, 1876.

To all whom it may concern:

Be it known that I, WILLIAM T. ORR, of Kewanee, in the county of Henry and State of Illinois, have invented a new and valuable Improvement in Sulky-Plows; and I do hereby declare that the following is a full, clear, and exact description of the construction and operation of the same, reference being had to the annexed drawings, making a part of this specification, and to the letters and figures of reference marked thereon.

Figure 1 of the drawings is a representation of a longitudinal vertical section of my sulky-plow, and Fig. 2 is a plan view thereof.

This invention has relation to improvements in sulky-plows.

The nature of the invention consists in a vertically-vibrating arm, pivoted at one end to the axle-tree and at the other to the front end of a plow-beam, extending to the front beyond the axle-tree aforesaid, in combination with mechanism which will depress the front end of the said beam and raise its rear end, whereby the operation of raising the plow from the ground will be greatly facilitated and expedited.

It also consists in the arrangement and novel construction, in connection with a vertically and horizontally vibrating plow-beam, of an arm pivoted at one end to the beam and at the other to the axle of a sulky-plow, and a rod connecting the said arm to the mechanism for raising or depressing the front end of the said beam, and in the novel construction of a knuckle-joint, all as hereinafter shown and described.

In the annexed drawings, the letter A designates a preferably wooden axle-tree, having on one end a fixed metallic axle-arm, *a*, carrying one of the transporting-wheels, B.

The other wheel, B', is applied upon an arm, *a'*, projecting at right angles from a flat metallic plate, *b*. This plate *b* is pivoted, so as to have vertical vibration edgewise, to a second angular plate, *b'*, secured by means of a tang, *c*, to the remaining end of the axle-tree, and it is provided upon its rear edge with rack-teeth *d*, arranged in the arc of a circle, and inside of said teeth with a slot, *d'*, concentric with the curvature of the cogged edge.

Plate *a'* is prevented from lateral displacement relative to plate *b* by means of a guide-pin, *e*, which is extended through slot *d'*, and screwed into the said plate *b*. This end of the axle-tree is raised or lowered by vibrating the plate *b* downward or upward, thus accommodating the apparatus to the slope of hill-sides, through the medium of a lever, C, and it is locked at any degree of elevation or depression by means of a pawl, *f*, which is held to its engagement with ratchet-plate *d* by means of a coiled spring, *g*, arranged on pawl *f* between two spaced lugs, *h*, in which the said pawl is guided. This pawl is disengaged from the ratchet-plate through the medium of an angular lever, D, pivoted at or near the power end of lever C, and connected to the said pawl by means of a rod, *i*, and will be returned to its engagement therewith by the reaction of spring *g*.

The pole E will be bolted to the axle-tree near the fixed arm *a*, and will have secured thereto, on its side nearest the driver's seat F, a segmental rack-wheel, G, the cogged surface of which will be uppermost.

A knee or bell-crank, G', will be pivoted to this rack-wheel, which will have a lever, H, secured thereto, which vibrates vertically in the length of the apparatus, and carries a pawl, *f'*, a coiled spring, *g'*, reciprocating through lugs *h'*, an angular knee-lever, D', and a connecting-rod, *i'*, of the same construction, and serving a similar purpose, to that of the corresponding parts above described on lever C.

The front end of the knee-crank G' will be connected, by means of a rod, *j*, with a vertically-vibrating arm, I, having its bearings in two spaced brackets, *k*, secured to the front vertical face of the axle A, the said rod being pivoted both to the crank and arm. This latter extends considerably to the front beyond the said axle-tree, and will be provided with an eye, *l*, at right angles to the length of the same, through which will be passed from below a **1**-shaped bolt, *m*, which will be secured to the arm by means of a nut applied upon its threaded projecting end. The arm *n* of bolt *m* will be tubular, and of course at right angles to the journal-arm *n'* in the eye *l*.

The plow-beam J and standard J' will be of

iron, and a plow, K, will be secured upon the end of the latter in the customary manner. The front end of the beam will be forked, as shown at L, and the arm n of bolt m will fit snugly between the arms of the fork.

M represents a bolt, which is passed through perforations in the fork, registering with the bore of the said arm n , and allows the beam to vibrate freely up or down, the other arm, n' , in eye l , allowing it to vibrate laterally with equal facility.

By this construction a universal joint of great strength, simplicity, and accuracy is formed, which will allow both lateral and vertical adjustment to the plow-beam, and by throwing lever H to the front the clevis end of the plow-beam will be lowered, causing the plow to take or bite more deeply into the ground. By reversing the lever an opposite result will be attained.

N represents a curved metallic bar, pivoted at one end to the beam, and extending, as to the other, above the axle through a strong staple, o , secured to lever H. This bar is provided upon its under side with a series of serrations, p , having a rearward bite, so that when the lever H is thrown back it will not catch upon the lower arm of the staple. When it is thrown to the front, however, the bar N will take hold and the plow be raised up out of the ground into the position shown in Fig. 1.

While the plow is being raised from the rear of the axle by the arm N and lever H the same movement will actuate the bell-crank, and, through the medium of the connecting-rod and arm, depress the front end of the beam, thus disengaging the plow from the ground by a backward movement thereof, and greatly facilitating the raising of the same. This will be appreciated in the event of the plow becoming hung under a strong root in new ground, when, instead of tearing through it, a disengagement may be effected by throwing the plow backward from the root without backing the sulky.

In practice, arm I will have horizontal play upon a pin, q , attached to and at right angles to the journal-section r thereof, thus allowing the front end of the beam to be thrown to the right or left, as may be required, without changing the direction of the sulky.

In hard ground it sometimes is requisite to hold the heel of the plow down. This is done by raising the bar aforesaid N until one of the notches t in the upper edge thereof is engaged with the staple, then inserting a pin into a perforation in the lever H, thus holding

the bar and staple together, and effectually attaining the desired result.

Bolt M, before alluded to, extends inward a considerable distance, and affords a journal for a vertically-vibrating walking-beam lever, P, having a short lower arm, w , and an upper one twice as long, or thereabout, w' .

The double-tree Q is attached to the free end of the lower arm w by a pivoted rod, x , and the single-tree R to the upper end of the long arm w' by a similar rod, x' , thus, through the vibrations of the beam aforesaid and the unequal lengths of the arms w w' , effectually equalizing the draft.

The single-tree will be prevented from binding on the double-tree by means of a rigid rod, y , pivoted at each end to one of rods x x' . It will also hold them in proper relation to each other.

I claim—

1. The vibrating arm I, journaled in front of the axle-tree, and having both vertical and horizontal movement, adapted for use substantially as specified.

2. In combination with the vertically-vibrating beam having a curved serrated rod, N, and the vertically-vibrating arm I, to the end of which the said beam is pivoted, the connecting-rod j , vibrating knee-crank G', lever H, having staple o , a pawl, f' , and a mechanism for actuating the same, substantially as specified.

3. The arm I, having universal movement relative to the axle-tree, in combination with a vertically and horizontally vibrating beam and a rod for sustaining its front end, as set forth.

4. The rod I, pivoted to the axle, and having a vertical eye, l , in its free end, in combination with the J-shaped bolt m , having tubular arm n and an attaching-nut, u , the forked front end of a plow-beam, and a bolt passing through eyes in the fork, registering with the bore of bolt m , substantially as specified.

5. The equalizer, consisting of the walking-beam P, having arms w w' of unequal lengths, the rods x x' , connecting the double-tree and single-tree, respectively, with the said arms, and the regulating-rod y , connecting rods x x' , combined and arranged substantially as specified.

In testimony that I claim the above I have hereunto subscribed my name in the presence of two witnesses.

WILLIAM T. ORR.

Witnesses:

WILSON CARSON,
HENRY N. GRAHAM.