

H. R. TOWNE.

BOLTING-MECHANISM FOR SAFE AND VAULT-DOORS.

No. 194,274.

Patented Aug. 14, 1877.

Fig. 1.

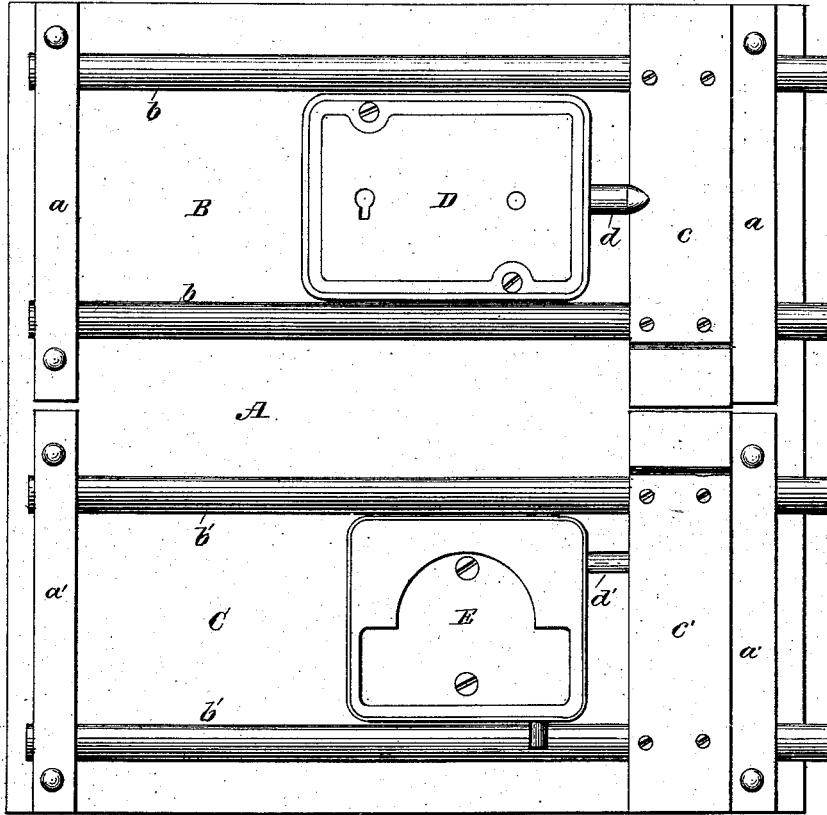

Attest.

Geo. W. Breck  
John F. Paret

Inventor.

Henry R. Towne.  
By his atty. Baldwin, Hopkins & Peyton.

H. R. TOWNE.

BOLTING-MECHANISM FOR SAFE AND VAULT-DOORS.

No. 194,274.

Patented Aug. 14, 1877.

Fig. 2.

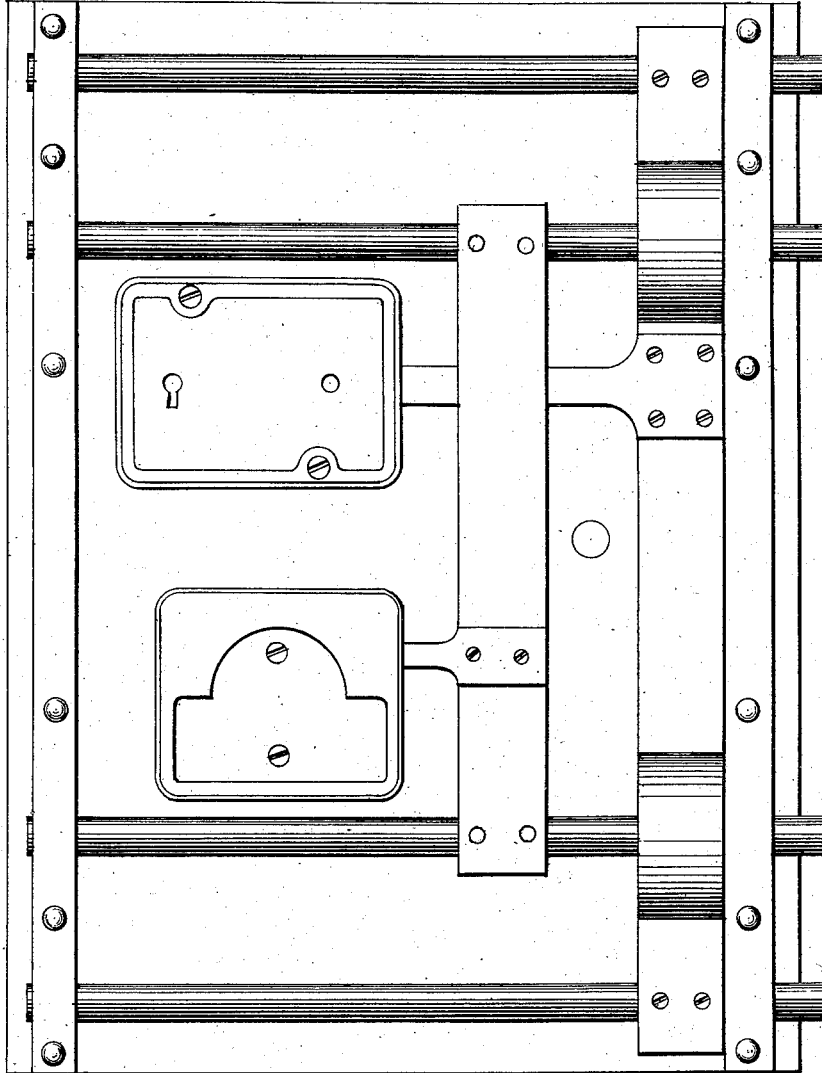

Attest.

Geo. W. Breckl.

John J. Paret

Inventor.

Henry R. Towne.

By his Atty.

Baldwin, Hopkins, & Peyton.

H. R. TOWNE.

BOLTING-MECHANISM FOR SAFE AND VAULT-DOORS.

No. 194,274.

Patented Aug. 14, 1877.

Fig. 3.

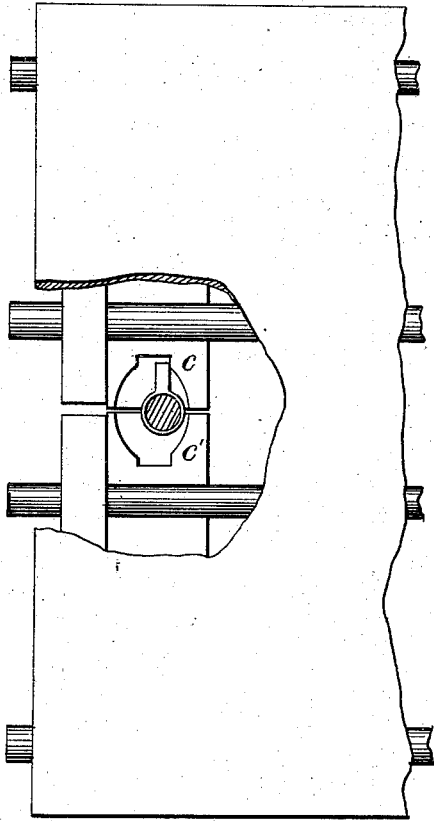
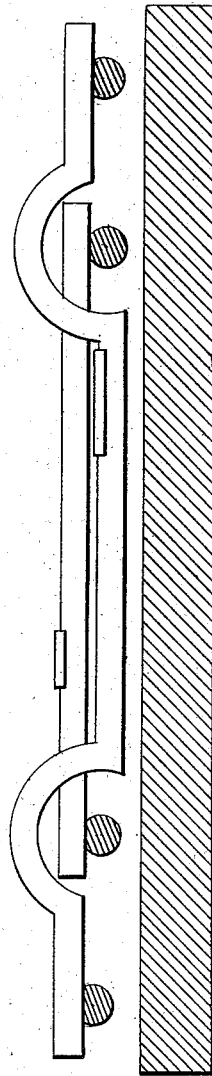

Fig. 4.



Attest

Geo. W. Breck

John D. Paret.

Inventor.

Henry R. Towne.

Baldwin, Hopkins & Peaton

# UNITED STATES PATENT OFFICE.

HENRY R. TOWNE, OF STAMFORD, CONNECTICUT, ASSIGNOR TO THE YALE LOCK MANUFACTURING COMPANY.

## IMPROVEMENT IN BOLTING MECHANISMS FOR SAFE AND VAULT DOORS.

Specification forming part of Letters Patent No. 191,274, dated August 14, 1877; application filed July 19, 1877.

*To all whom it may concern:*

Be it known that I, HENRY R. TOWNE, of Stamford, in the county of Fairfield and State of Connecticut, have invented certain new and useful Improvements in the Bolting Mechanism for Safe and Vault Doors; and I do hereby declare that the following is a full, clear, and exact description thereof, which will enable others skilled in the art to which it appertains to make and use the same, reference being had to the accompanying drawings, and to letters of reference marked thereon, which form a part of this specification.

The object of my invention is to increase the strength and security of safe and vault bolt-works; and my invention consists in combining, on a safe or vault door, two independent sets of bolt-work, operated by a single spindle, and constructed to be secured by different and independent locks, so that if one set should become disabled the other will not necessarily be affected, and will still secure the door.

In the drawings, Figure 1 represents one form of my invention; Fig. 2, another; Figs. 3 and 4, sectional views of Figs. 1 and 2.

Referring to Fig. 1, A indicates a safe or vault door; B, the upper set of bolt-work, and C the lower set. The upper set, carried by the two frame-pieces or bolt-bearings *a a*, and consisting of the two bolts *b b*, the string-bar *c*, and the tongue-piece *d*, is shown dogged by a combination-lock, D. The lower set, carried by the two frame-pieces *a' a'*, and consisting of the two bolts *b' b'*, the string-bar *c'*, and the tongue-piece *d'*, is shown dogged by a time-lock, E; but in this example, as in all variations of details of construction involving my invention, both sets of bolts or bolt-work may be dogged by combination-locks, or by time-locks, or by any other varieties of locks, if preferred.

The same frame-pieces or bearings might be made to carry both sets of bolts; but I prefer to have separate frames, as well as bolts and locks, for greater security, as, if the frames of one set of bolts should be forced from the door, the other set would still hold.

The two sets of bolt-work shown in Fig. 1

are so constructed as to be thrown forward and retracted alternately by the same spindle, the ends of the string-bars in juxtaposition being notched to receive a cam on the spindle for that purpose, as shown in Fig. 3. The spindle slides in and out, and the cam, entering one notch, and being turned to throw one set of bolts, is withdrawn and turned, and may then enter the other notch and throw the other set of bolts; but there are other devices by which the same object can be accomplished, well known to mechanics, and not necessary to specify. Separate spindles might be employed—one for each set of bolt-work—if desired.

In Fig. 2 of the drawings I have shown a modification of my invention, in which one set of bolt-work is within the boundaries of the other, but both in the same vertical plane, the outside set having its string-bar arched, as shown in the sectional view, Fig. 4, and its tongue-piece elongated and sliding under the string-bar of the middle set. In this modification both sets may be thrown by a single spindle located between the sides of the two string-bars, and provided with a cam suitable for the purpose, and both sets are shown carried by the same frame.

These modifications serve to show the variations of details that may readily be made without departing from the substance of my invention for improving the agencies, or organization of agencies, for the security of safe and vault doors, and at the same time they serve also to more clearly exemplify and communicate a knowledge and understanding of my invention.

If a time-lock is employed to dog one set of bolts, (or both, as the case may be,) it is of course to be understood that it must be provided, as time-locks have always been, with a device whereby, or, in other words, be of such construction that the bolt-work may remain in the retracted position for shutting the door, and thereupon be automatically locked—that is to say, the time-lock must have a device or feature of construction and mode of operation such that, while the safe-door is open and the set of bolts retracted, the lock can be wound

up and so set or adjusted that when the door is shut, and the bolt-work cast into engagement with the jamb, it will there be locked by the time-lock from the inside, either by the mere act of casting the bolts, as in the English patent of Rutherford, granted in 1831, or the American patent of Lyman Derby, granted November 2, 1858, or else by the operation of the time-movements, as in the patent of Samuel A. Little, granted January 27, 1874, or in some other way. It is also of course to be understood that the time-lock must have the capacity, after locking or dogging the bolt or bolts from the inside, of automatically releasing them at the predetermined time for which the lock has been set; but as these are ordinary features and functions of all time-locks, from the earliest to the latest, without which they could not be made to work either the dog-bolts carried in their own lock-cases, or bolts carried by bearings on a door, I do not deem it necessary to refer particularly to the construction of a time-lock to be used with my invention, more than to that of a non-time lock to be used in connection with it, both being well-known classes of locks of considerable antiquity, and all varieties of each class being capable of application and use with more or less facility in connection with my invention; but I prefer to use the

Yale time-lock and the Yale combination-lock. By thus having two separate sets of bolt-work, one set may, if desired, be made lighter than the other for easy use in frequently fastening and unfastening during the day; but even without this one set unprovided with a time-lock can be used with greater ease and facility during the day than is now practicable with all the ponderous bolt-work in a single train, and it can be re-enforced at night by the other set, provided, if preferred, with a time-lock.

Having thus described my invention, what I claim, and desire to secure by Letters Patent, is—

The combination, on a safe or vault door, of two independent sets of bolt-work, constructed and arranged to be dogged respectively by separate locks, (one a time-lock and the other a non-time lock, if preferred,) and to be operated by a single spindle, substantially as described.

In testimony that I claim the foregoing as my own I affix my signature in presence of two witnesses.

HENRY R. TOWNE.

Witnesses:

SCHUYLER MERRITT,  
WALTER FULLER.