

E. D. CLAPP & F. VAN PATTEN.
 BLANKS FOR SHIFTING RAILS OF CARRIAGES.

No. 194,292.

Patented Aug. 21, 1877.

Fig. 1.

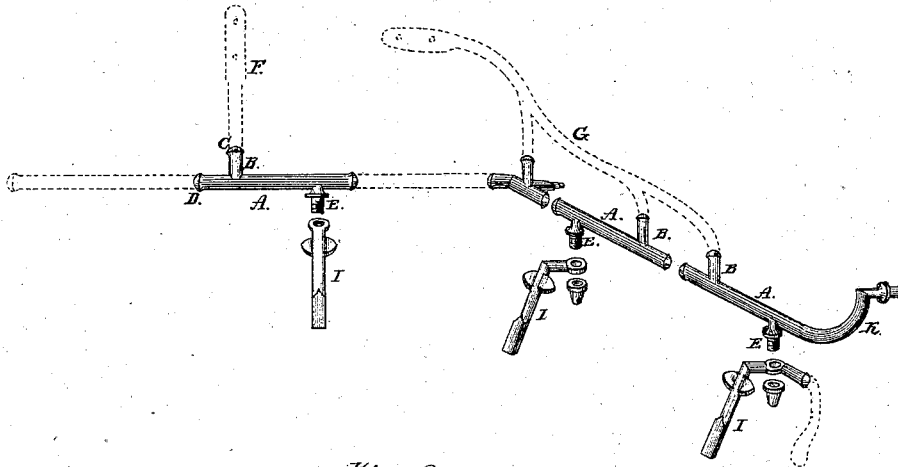

Fig. 2.

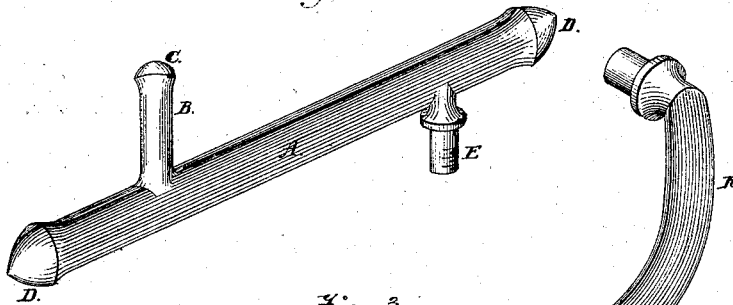
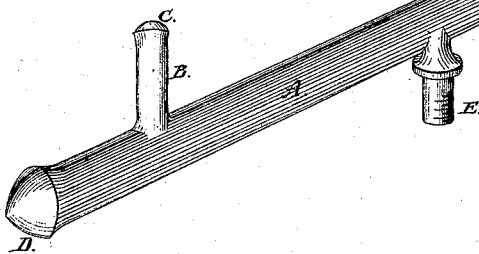

Fig. 3.



Witnesses
Geo. Graham.
John C. Kluber.

Inventors,
E. D. Clapp, and
Frederick Van Patten.

by *Munsen & Philipp*
 Attorneys.

UNITED STATES PATENT OFFICE.

EMEROUS D. CLAPP AND FREDERICK VAN PATTEN, OF AUBURN, NEW YORK.

IMPROVEMENT IN BLANKS FOR SHIFTING-RAILS OF CARRIAGES.

Specification forming part of Letters Patent No. **194,292**, dated August 21, 1877; application filed May 29, 1877.

To all whom it may concern:

Be it known that we, EMEROUS D. CLAPP and FREDERICK VAN PATTEN, of the city of Auburn, county of Cayuga and State of New York, have invented certain new and useful Improvements in Forgings for Shifting-Rails of Carriages; and we do hereby declare the following to be a full, clear, and exact description of the same, reference being had to the accompanying drawings, forming a part of this specification.

Figure 1 is a perspective view of half of the pieces that make a shifting-rail, showing the places where our forging may be used. Fig. 2 is a perspective view of a forging for a shifting-rail embodying our invention. Fig. 3 shows its connection to the goose-neck of a shifting-rail.

Prior to our invention it was customary for carriage-blacksmiths to forge by hand the shifting-rail of carriages, welding the parts that are at an angle to each other, and shaping the same in the ordinary expensive manner of doing this by hand. When made, these welds were liable to be easily broken, and were seldom, if ever, smooth and symmetrical to the eye.

To lessen the expense of the manufacture of such shifting-rails, to make those portions of them where the different pieces are joined at an angle to each other stronger, smoother, and more symmetrical than when made by hand, is the object of our invention; and it consists in a forging, as will be more fully hereinafter pointed out and claimed.

Our forging consists of a bar of metal, A, having formed as an integral part therewith the lugs B and E, all shaped as shown.

This forging is made by upsetting the iron

from which the lugs and bar are made, and swaging the whole in suitable dies to the form shown, swells C on the lug B and D on the bar being provided to readily weld the forging to the other parts of the shifting-rail.

In Fig. 3 we have shown our forging welded to the goose-neck K for the carriage slat-irons.

By referring to Fig. 1 of the drawings, it may be seen that this forging can, in making the shifting-rail, be used so that the lug B may be welded to the brace F of the lazy-back, or so that said lug may be welded to the hand-rail G. In all these cases the lug E, having a screw cut on it, forms a means of connection with the feet I. Thus, by the use of our invention, for each shifting-rail at least four, and often more, welds at right angles, and four lugs for the feet made smoother and more symmetrical to the eye, and stronger than can be made by hand, are ready for use by the blacksmith, and at a cost much less than if made by hand.

Having thus fully described our invention and the merits it possesses, what we claim as new, and desire to secure by Letters Patent, is—

As a new article of manufacture, the forging, consisting of the bar A, having lugs B and E, substantially as shown and described.

In testimony whereof we have signed our names to this specification in the presence of two subscribing witnesses.

EMEROUS D. CLAPP.
FREDERICK VAN PATTEN.

Witnesses:

HORACE T. COOK,
D. E. CLAPP.