

H. WADSWORTH.
 PLOTTING-INSTRUMENT.

No. 194,486.

Patented Aug. 21, 1877.

Fig: 1.

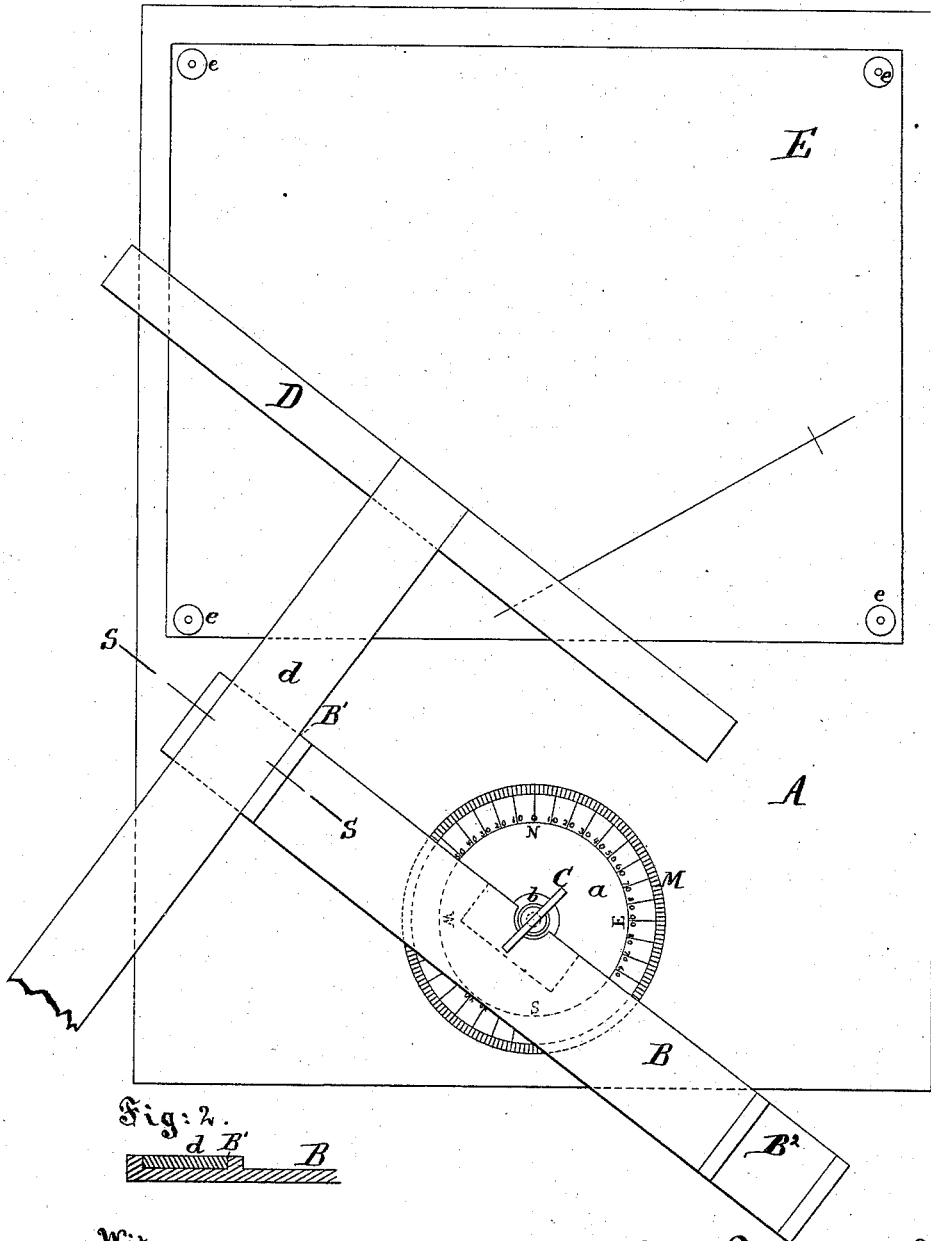
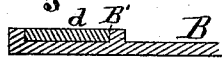

Fig: 2.



Witnesses:

A. Henry Gentner
Chas. C. Stetson.

Inventor:
H. Wadsworth
 by his attorney
J. D. Stetson

UNITED STATES PATENT OFFICE.

HENRY WADSWORTH, OF DUXBURY, MASSACHUSETTS.

IMPROVEMENT IN PLOTTING-INSTRUMENTS.

Specification forming part of Letters Patent No. 194,486, dated August 21, 1877; application filed April 25, 1877.

To all whom it may concern:

Be it known that I, HENRY WADSWORTH, of Duxbury, in the county of Plymouth, State of Massachusetts, have invented certain new and useful Improvements relating to Plotting-Instruments for use by Surveyors and others; and I do hereby declare that the following is a full and exact description of what I consider the best means of carrying out the invention.

I produce on the surface of a plane table, or on a plate sunk flush therewith, or about flush therewith, an accurately-divided circle, with the four cardinal points of the compass distinctly marked, and to the center of that circle secure, by a thumb-screw, a metallic eye, to which is fixed a straight-edge, of wood or metal, having the line of one edge crossing the center of the circle, and the other edge parallel thereto. On slacking the thumb-screw this straight-edge may be swung around to any desired position, and, the circle being graduated and marked in degrees, the straight-edge may be placed at any angle desired, and by turning the thumb-screw may be firmly clamped there. I secure the paper on the board by the side of the circle, or on a separate board carefully held in position against the edge of the first, or partly on each.

I draw the several lines by the aid of a T-square, the blade of which is held in a close-fitting shallow groove made across the straight-edge. There are, preferably, two or more of these grooves, to allow the T-square to be shifted from one to another at will.

The accompanying drawings form a part of this specification.

Figure 1 is a plan view of the entire device in condition for work, and Fig. 2 is a vertical section through a portion on the line S S in Fig. 1.

Similar letters of reference indicate like parts in all the figures.

A is a well-seasoned board of suitable size, and *a* is a plate of metal, sunk in its upper surface, and carrying a carefully-graduated circle, M, distinctly divided in four quarters—east, west, north, and south.

B is a straight-edge, preferably of considerable thickness, having a firmly-fixed eye, *b*, of metal, through which a thumb-screw is in-

serted (through the center of the circle M) into the board A, the whole being prepared with reference to easy and correct adjustment of the upper edge of the straight-edge B to the proper number of degrees and parts of degrees from any of these cardinal points. D is the T-part, and *d* the blade of an accurate T-square.

B¹ B² are wide grooves across the straight-edge, near the ends, corresponding accurately to the width of the blade of the T-square D.

The paper on which the drawing is to be made is represented by E. Any ordinary or suitable means may be employed to hold this paper. I have indicated pins *eeee*. If, for example, the notes call for a first line "north 61°, east 20 rods, 19 links," the thumb-screw C is slackened and the straight-edge turned on its center, and so set on the circle M that its edge shall stand in the required approximately northeast and southwest position. It is then clamped in that position by tightening the screw C. The blade *d* of the T-square is now applied in the cross-groove B², and the T-square moved outward, sliding in the groove. Of course the outer face of the T-part D is always parallel to the straight-edge. When moved out till it strikes the initial or starting point it is stopped, and a fine line is drawn by its aid with a pencil. The proper scale having been determined for the plot, the distance is laid off on this line, and the terminal point is marked.

Suppose the next course and distance to be "north 53°, west 29 rods, 10 links," the thumb-screw C is slackened, the straight-edge turned around to the required approximately northwest and southeast direction, clamped anew, and the operation repeated; but this time it will be found better to lay the T-square in the other groove, B¹.

Thus I proceed, each time carefully clamping the straight-edge B in the position indicated by the graduations on the circle, and then applying the T-square in the most convenient groove, B¹ or B², and sliding the T-square out with its T-part necessarily parallel to B until its farther edge coincides with the proper terminal of the desired line, and then a fine line is drawn by its guidance, on which

the proper distance is laid off, the terminal on which serves as the starting-point for the next course, and so on.

I prefer to make the graduated circle M with several concentric lines, the outer one being divided in fine graduations without interruption by figures or the like, the next graduated in fives, and the third in tens of degrees, one or both of the inner circles carrying the appropriate figures, and within the whole placing (by engraving or otherwise producing) the conspicuous marks N., E., S., W., for north, east, south, west.

Many modifications may be made in the details by any good mechanic.

I prefer to form the eye *b* of brass, letting flush on the under face of the straight-edge, and projecting to the required amount at the center; but the straight-edge may be carried out the full thickness, being simply swelled at that point to accommodate the screw with its center in the line of the adjacent edge.

I prefer to form the grooves B¹ B² by simply thickening the straight-edge on each side thereof, leaving the proper upper surface of the straight-edge for the bottom of the groove, as indicated in Fig. 2. One alone may serve, or three or more may be used, if preferred. Instead of mere open grooves, there may be a button or the like clamp for confining the T-square in the recesses B¹ B².

I prefer to employ a straight-edge in a cheap form, of well-seasoned wood, simply fortifying the edges with metal to increase the perfection and durability; but there may be various refinements, as the addition of a projecting plate from the straight-edge adjacent to the finest graduations of the circle M, which plate may be engraved with a vernier scale.

A tangent-screw may be applied to aid in adjusting the straight-edge with delicacy; and, where the expense will be warranted, the instrument may be further provided with an efficient microscope, permanently mounted over this point to increase the accuracy of the readings.

A cheap instrument, sufficiently exact for ordinary purposes, may be made with fine wood for the movable parts, and the graduated circle of pasteboard.

To promote durability, there should be a brass nut let into the under side of the instrument, into which the screw C shall engage.

I believe that the instrument may be available for other uses than plotting, among which are projections for architects and draftsmen generally.

I claim as my invention—

1. The straight-edge B *b*, cross-grooved, as shown at B¹ B², and turning on an axis in the center of the circle M, in combination with a T-square, D *d*, and with the board A, adapted to support the paper, as and for the purposes herein specified.

2. The clamping-screw C, in combination with the grooved straight-edge, circle, and board, to allow the whole to be held firmly while the T-square is slid in and out in the grooves or guides, and the lines drawn, as herein specified.

In testimony whereof I have hereunto set my hand this 19th day of April, 1877, in the presence of two subscribing witnesses.

HENRY WADSWORTH.

Witnesses:

THOMAS W. HERRICK,
H. BRIGGS WADSWORTH.