

C. LEMLEY.
SLED-BRAKES.

No. 194,498.

Patented Aug. 21, 1877.

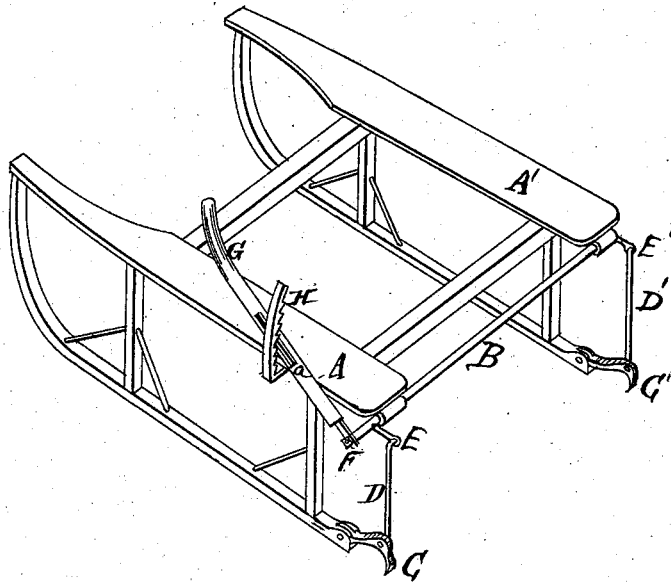

WITNESSES:

Geo. H. Wood
G. A. C. Smith

Calif Lemley
INVENTOR.

J. M. C. Perkins
ATTORNEY.

UNITED STATES PATENT OFFICE.

CALIP LEMLEY, OF DUTCH CREEK, IOWA.

IMPROVEMENT IN SLED-BRAKES.

Specification forming part of Letters Patent No. **194,498**, dated August 21, 1877; application filed January 25, 1876.

To all whom it may concern:

Be it known that I, CALIP LEMLEY, of Dutch Creek, in the county of Washington and State of Iowa, have invented certain new and useful Improvements in Sled-Brakes; and I do hereby declare that the following is a full, clear, and exact description thereof, that will enable others skilled in the art to which it appertains to make and use the same, reference being had to the accompanying drawings, and to the letters and figures of reference marked thereon, which form a part of this specification.

The same letters and figures of reference are used to indicate the corresponding parts.

After describing the invention, its nature and extent will be shown in the claims.

A is the sled; B, the crank-shaft; C, the brakes at the rear end of either of the sled-runners; and D the lever which connects the brakes C with a projecting rod of crank-shaft B at the point E. G is the handle, pivoted to the crank-shaft at the extremity F. *a* is a flange on the side of the handle G, which engages in the ratchet H.

The brakes C C lock the sled by elevating the handle G, which is held in any desired position by the ratchet H. The top of the ratchet H does not project inward beyond a vertical line on the outside of the sled.

The elements of my invention, by themselves, I do not claim as new.

Having now fully described my invention, what I claim as new, and desire to secure by Letters Patent, is—

The dogs C C', attached to each runner, the levers D D', both operated by the crank-shaft B, extending across and attached to both raves A A' of the sled, in combination with the lever G and ratchet H, substantially as described, and for the purposes set forth.

In testimony that I claim the foregoing I have hereunto set my hand this 17th day of August, 1875.

CALIP LEMLEY.

Witnesses:

ELI HARBAUGH,
H. ENGEL.