

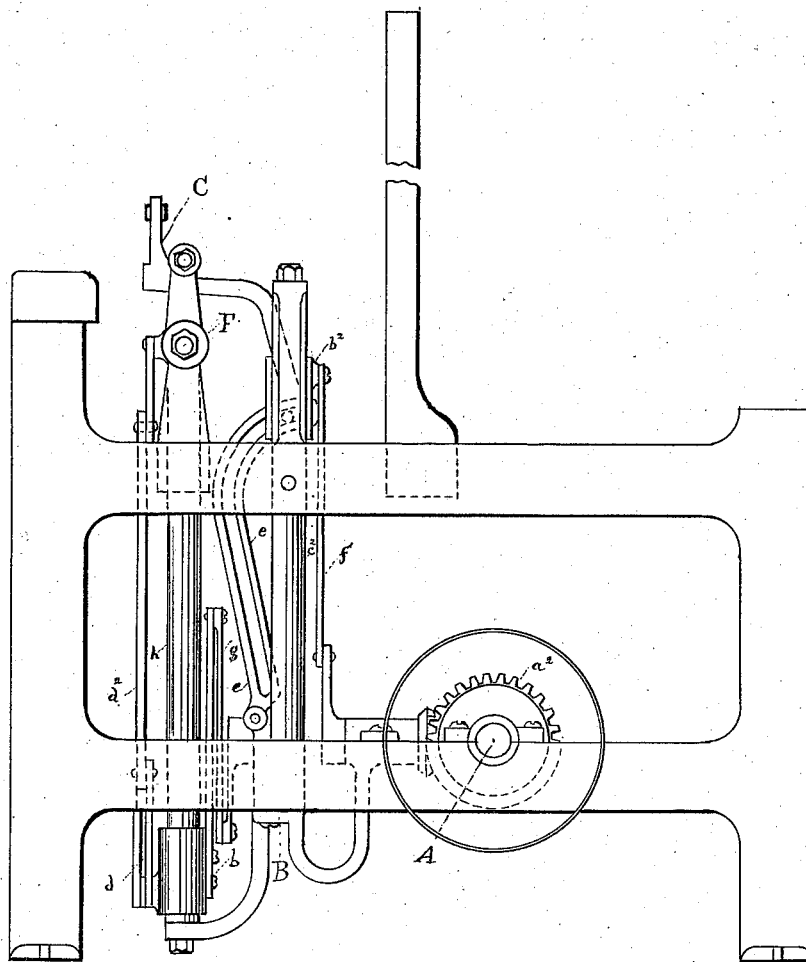

E. H. GRAHAM.  
LOOMS.

No. 194,517.

Patented Aug. 28, 1877.

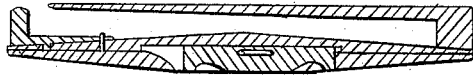
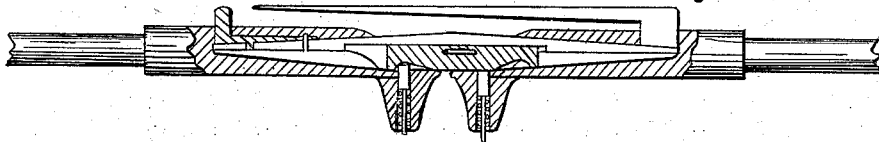

*Witnesses*  
*John H. Small*  
*Joa. A. Philbrick*

*Edmund H. Graham Inventor*

# UNITED STATES PATENT OFFICE.

EDMUND H. GRAHAM, OF BIDDEFORD, MAINE, ASSIGNOR OF A PART OF HIS RIGHT TO REUBEN W. RANDALL, WILBUR F. LUNT, JOSEPH B. PALMER, AND CHARLES HARDY, OF SAME PLACE.

## IMPROVEMENT IN LOOMS.

Specification forming part of Letters Patent No. 194,517, dated August 28, 1877; application filed October 23, 1876.

*To all whom it may concern:*

Be it known that I, EDMUND H. GRAHAM, of Biddeford, in the county of York and State of Maine, have invented a new and Improved Loom, of which the following is a specification:

My invention relates to that class of looms wherein the shuttle is carried through the warp upon arms attached to sliding stands, moving upon a fixed track parallel with the front side of the loom, the shuttle containing a locking device, by means of which the arms, as they penetrate it, are adapted to be alternately locked and released, and the shuttle is alternately passed from one arm to the other as the ends of the arms are made to meet and recede in the warp.

The drawings, Sheets 1 and 2, form a part of the specification. Sheet 1 represents a front side elevation of the loom. Sheet 2 represents an end view, and also a sketch, showing the construction of such a shuttle as is referred to.

Like letters indicate same parts.

This loom differs from all others in the construction and mechanism of the devices for operating the shuttle and lathe.

The following description, reference being had to the drawings, is sufficient to enable those skilled in the art to construct said improved loom.

A represents the main driving-shaft, which is the only shaft extending lengthwise through the loom. This shaft has its bearings upon the lower section of the loom-frame. Three pinion-gears of same size are located upon this shaft, one near the middle, and the others near each end within the frame. The middle gear *a* moves the device operating the shuttle-arms; the other two gears move the devices, each of which operate respectively in the same manner the lathe-swords. B is a cross-beam, strengthening the lower front section of the loom-frame, and also supporting the stands and bearings of the lathe-swords, and devices operating the lathe-swords and shuttle-arms.

The following is a description of the mechanism operating the shuttle, viz: The gear *a*, located near the middle of the main shaft, drives a pinion-gear upon the end of a cross-

shaft. This cross-shaft rests in a bearing upon the beam B and extends across it. To the opposite end of the cross-shaft a crank is fixed. Attached to this crank is a lifting-rod, *g*, connected with the block *b* or movable bearing, which embraces and traverses the fixed upright standard *h*, the block being caused to rise and descend by means of the lifting-rod and connection attached to the crank aforesaid. To the opposite or front side of this block are attached two short bars or rods, *d d*, connected with two upright levers, *d' d'*, at a sufficient distance from the fulcrums, which, by means of connecting-rods, move the shuttle-arm stands *h' h'* back and forth on their track F. The lower ends of the short bars or rods *d d*, attached to the block *b*, do not rise so high as the level of the fulcrum of the long upright levers *d' d'*, so that whenever the driving-crank is passing the center, and suffers the greatest strain, these bars operate upon the upright levers substantially by lifting. The base of the shuttle-arm stands are fitted to and embrace the track upon which they are driven.

By the mechanism described the shuttle-arms carrying the shuttle are moved positively the certain distance necessary in order to accomplish successfully the transfer of the shuttle from one to the other while in the warp, it being a necessary requisite in order to operate such a shuttle successfully that the locking ends of the arms shall meet always at a certain fixed point in the warp.

The mechanism for operating the lathe is of no less importance, as in order to operate a shuttle of the kind referred to it is necessary that the reed shall be made to do its work in the brief time allowed while the shuttle-arms are withdrawn from and before they re-enter the warp. It is therefore necessary that the lathe shall remain fixed and immovable while the shuttle-arms and shuttle are in the warp.

I accomplish the operation of the lathe in manner following, viz.: The right and left lathe-swords *e e* are driven by like devices, operating simultaneously, and a description of one is sufficient. Attached to the main shaft A, nearly opposite to the lathe-sword *e*,

is a gear,  $a^2$ , driving a pinion-gear on the end of a short cross-shaft, the bearing of which is in a stand fixed to the rear of the beam B. On the opposite end of this cross-shaft, between the bearing and the beam B, is a crank, attached to which is a lifting rod or bar,  $f$ , connected with a sliding block,  $b^2$ , or bearing moving perpendicularly on an upright standard,  $c^2$ , by the side of the lathe-sword  $e$ . In this lathe-sword is a cam-path, straight, except near its upper extremity, where it is curved toward the rear of the loom sufficiently to give the necessary movement for the lathe. There is a stud,  $f^2$ , projecting from the side of the sliding block  $b^2$ , fitted to this cam-path. While the sliding block  $b^2$  is driven perpendicularly up and down, this stud, as it moves in the straight portion of the cam-path of the lathe-sword, holds it fixed and immovable, while the shuttle-arms are allowed sufficient time to transfer the shuttle through the warp, and the moment they have withdrawn from the warp the stud, as it ascends, enters the curve in cam-path of the sword, and at once the lathe beats up promptly, and is withdrawn seasonably for the shuttle-arms to enter the warp.

The shuttle-arms are sustained by stands  $h^2 h^2$ , made to fit and slide upon a cylindrical rod,  $F$ , having a groove upon its under side fitted with a set-screw, by means of which

the stand is made to fit the rod and run without vibration.

I claim as my invention—

1. The combination of the gear  $a$ , as located on the main shaft A, the cross-shaft and pinion-gear driven by it, the crank and lifting bar or rod  $g$ , with the sliding block  $b$ , the upright standard  $h$ , the compound levers  $d d$  and  $d^2 d^2$ , operating the shuttle-arms by means of the connecting-rods and standards  $h^2 h^2$ , substantially as described and set forth.

2. The means for driving the lathe from the main shaft, consisting of the combination of pinion-gears  $a^2$ , cranks, lifting rods or bars  $f$ , sliding blocks  $b^2$  upon the upright standards  $c^2$ , adapted to operate directly upon the lathe-sword  $e$ , substantially as set forth and described.

3. The combination of a lathe-sword,  $e$ , having a cam-path, as described, a stud,  $f^2$ , sliding block  $b^2$ , and means for moving the same perpendicularly upon an upright standard,  $c^2$ , substantially as set forth and described.

In testimony that I claim the foregoing I have hereunto set my hand this 16th day of October, A. D. 1876.

EDMUND H. GRAHAM.

Witnesses:

JOHN H. SMALL,  
IRA A. PHILBRICK.