

R. M. MELHUIH.

MACHINE FOR SEWING BUTTON-HOLES.

No. 194,610.

Patented Aug. 28, 1877.

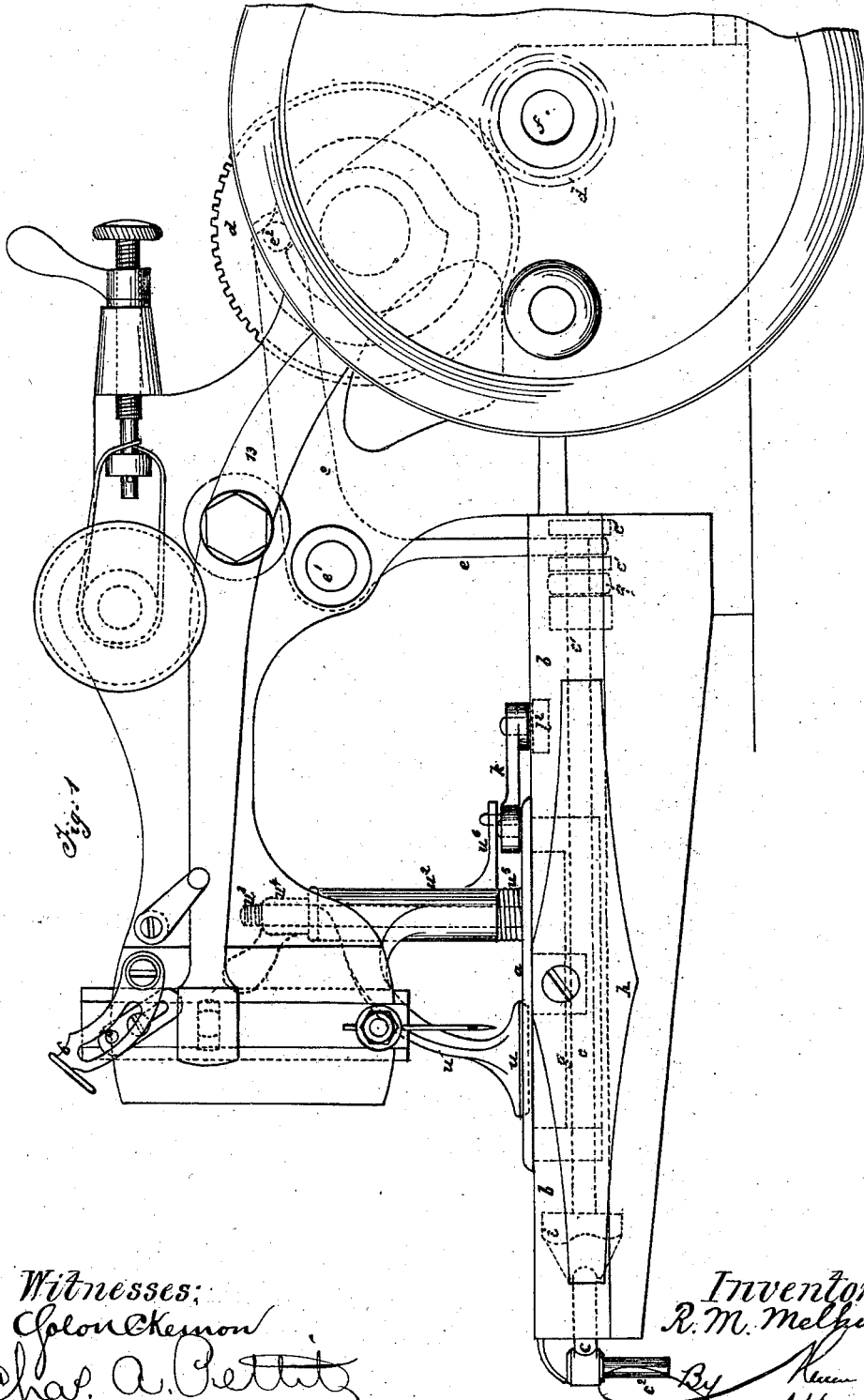

Witnesses:  
Colon Kennon  
Chas. A. Pettit

Inventor  
R. M. Melhuish  
By *Allen V. G.*  
Attorneys

R. M. MELHUIH.

MACHINE FOR SEWING BUTTON-HOLES.

No. 194,610.

Patented Aug. 28, 1877.

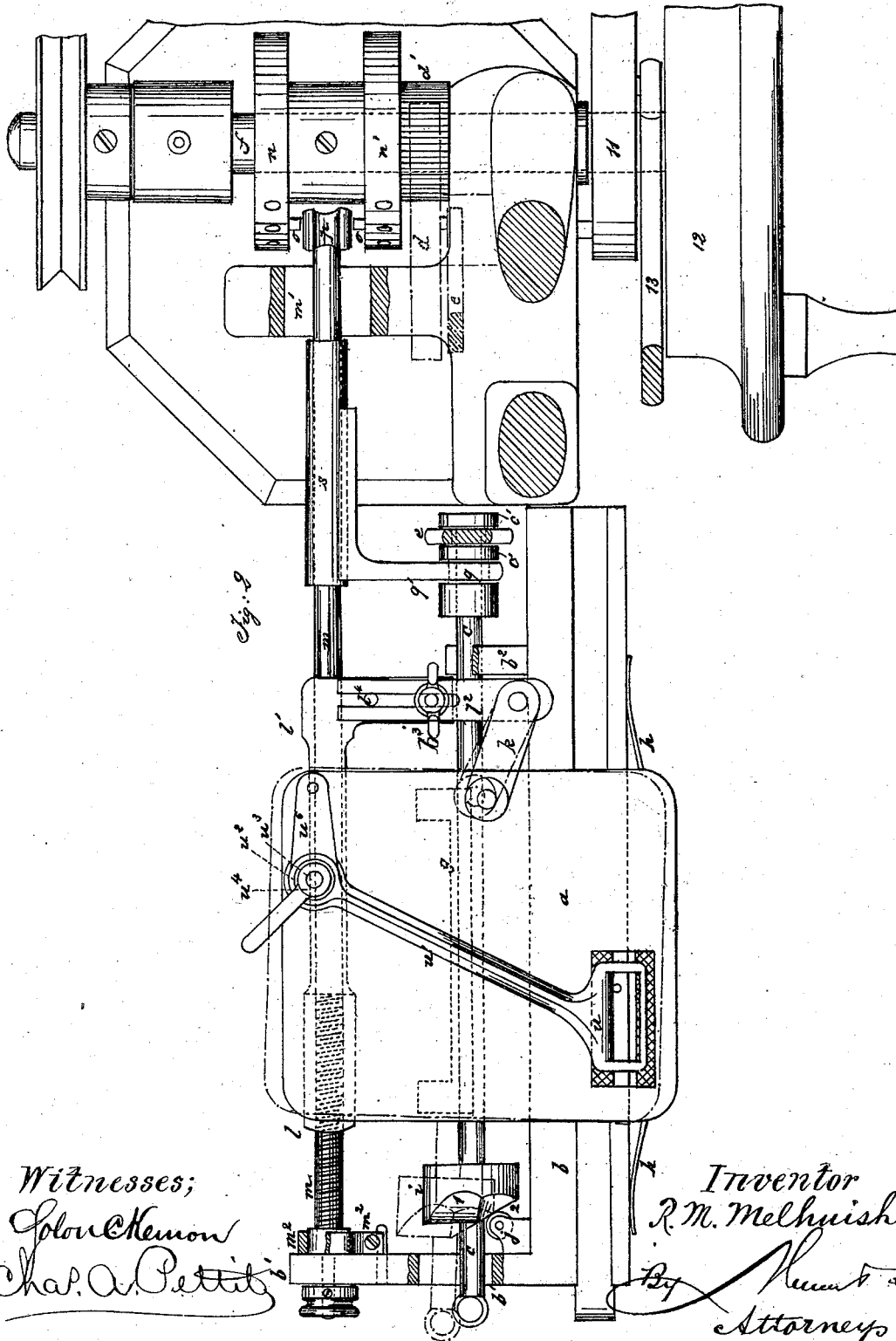

Witnesses;  
Colon Kemmon  
Chas. A. Pettit

Inventor  
R. M. Melhuish  
By [Signature] Attorneys

R. M. MELHUIJSH.

MACHINE FOR SEWING BUTTON-HOLES.

No. 194,610.

Patented Aug. 28, 1877.

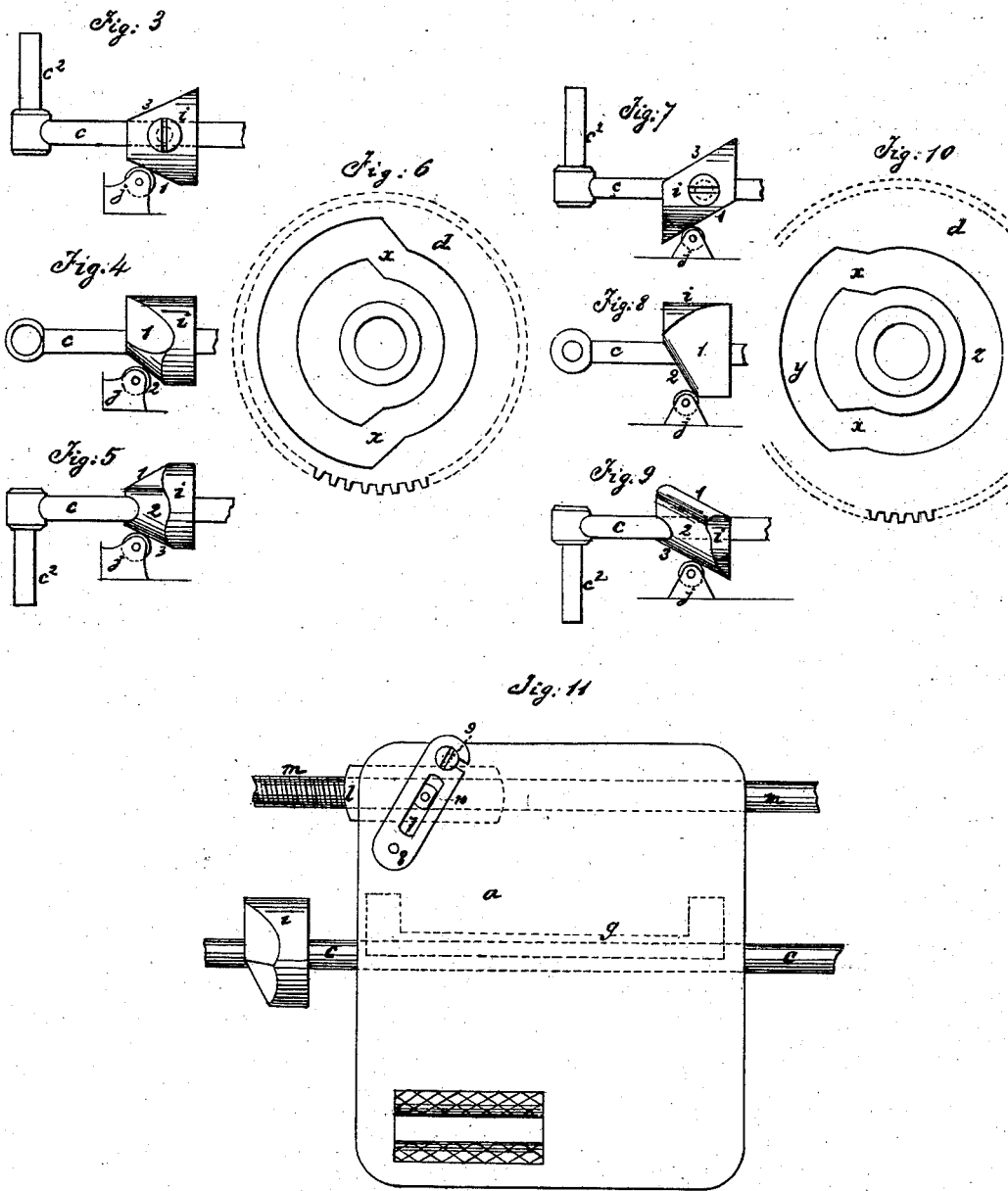

Witnesses,  
 John Kemron  
 Char. A. Pettit

Inventor  
 R. M. Melhuish  
 By *[Signature]*  
 Attorney

# UNITED STATES PATENT OFFICE.

RICHARD M. MELHUISE, OF HOXTON, ENGLAND.

## IMPROVEMENT IN MACHINES FOR SEWING BUTTON-HOLES.

Specification forming part of Letters Patent No. **194,610**, dated August 28, 1877; application filed March 17, 1876.

*To all whom it may concern :*

Be it known that I, RICHARD MATTHEW MELHUISE, of Hoxton, in the county of Middlesex, England, have invented a new and useful Improvement in Machines for Sewing Button-Holes; and I do hereby declare that the following is a full, clear, and exact description of the same.

My invention relates to mechanism adapted to sewing-machines of the Thomas or Howe type, for the purpose of sewing straight button-holes and fancy stitching. By my invention this is accomplished with ease and rapidity, it not being necessary to turn the fabric round in order to work the two edges and finish off the ends of the button-hole.

The said mechanism is for imparting to a movable cloth-plate, upon which the work is clamped, a vibrating to-and-fro motion across the line of the hole, and also a traversing motion in the direction of the hole to feed the work, as required.

In the accompanying drawings, Figure 1 represents a front elevation of a machine with my improvements applied thereto. Fig. 2 is a plan view of the same, the fixed bracket-arm being removed for the sake of clearness. Figs. 3, 4, 5, 6, 7, 8, 9, and 10 are detail views of different forms of cams and cam-wheels, by which the cloth-plate is vibrated. Fig. 11 is a modification applied to the cloth-plate.

*a* is the vibrating cloth-plate working upon the shuttle-box *b*, and vibrated by the rod *c* in the following manner: *c* is a round rod carried in slotted supports *b*<sup>1</sup> *b*<sup>2</sup>, and receiving endway motion from a cam-wheel, *d*, through the bent rock-lever *e*, pivoted at *e*<sup>1</sup> to the frame of the machine, and having at its extremity *e*<sup>2</sup> a pin with friction-roller working in the cam-groove of the wheel *d*, which is a spur-wheel driven by a pinion, *d*<sup>1</sup>, on the main shaft *f*, the other extremity of the lever *e* being forked and embracing the rod *c* between two collars, *e*<sup>1</sup> *e*<sup>2</sup>, fixed thereon.

The cloth-plate *a* is connected to the rod *c* by a bearing, *g*, extending across beneath the plate, to the under side of which it is fixed by studs, and it is grooved to embrace the rod *c*, against which it is maintained by the action of a spring, *h*, attached at its center to a stud on the under side of the plate *a*, and pressing

with its two ends against the front side of the shuttle-box. The rod *c* slides freely in bearing *g*. The spring *h* may, however, be otherwise disposed.

*i* is a cam fixed on rod *c*, and having three faces, 1 2 3, at different angles and directions, which vary according to the kind of stitch it is desired to produce. The cam *i* works against a fixed projection, *j*, or, preferably, against a friction-roller mounted at the back of the shuttle-arm; as shown. Either face of the cam can be readily brought into contact with said roller *j* by simply turning rod *c* partly round by means of the thumb-lever *e*<sup>2</sup>.

In Fig. 3 the cam *i* is shown in position for sewing that side of the intended button-hole which is nearest the operator, or the front of the machine, the face 1 being in contact with *j*. In Fig. 5 the same cam is shown with face 3 against *j* for sewing the opposite side of the button-hole, and in Figs. 2 and 4 it is shown with face 2 against *j*, or in position for "barring" the ends of the button-hole.

The action of the cam is as follows: In Fig. 2, when (by the motion of the rod *c* toward the left) the cam *i* is moved to the position shown in dot-and-dash lines, the rod *c* will be vibrated or moved laterally, as shown, thereby vibrating the cloth-plate *a*, as also shown in dot-and-dash lines, the said plate then returning to its original position on the return movement of the rod *c*. Face 3 of the cam is inclined at the same angle to the rod *c* as face 1, but in the opposite direction, (so that when rod *c* is half rotated it assumes the same direction relatively to the stud *j*, as shown in Fig. 5,) the cam being of reduced thickness on this side, so that face 3 being rather nearer to the center-line of rod *c* plate *a* is caused by the spring *h* to take up a position nearer to the operator, so as to bring the side of the button-hole farthest from the operator beneath the needle, the plate being vibrated to the same extent as by face 1. Face 2 is inclined more transversely to rod *c* in order that with the same amount of movement of rod *c* the plate *a* will be vibrated to twice the extent as by either of the other faces, in order to "bar" or sew completely across the ends of the button-hole. With a cam, *i*, of this shape the groove in cam-wheel *d* is of the shape shown in Fig.

6, and the relative proportion of this wheel  $d$  to the pinion  $d'$ , by which it is driven, is as two to one.

$l$  is a nut, working along the feed-screw  $m$ . Upon this nut  $l$  the plate  $a$  rests, and it is connected thereto, so as to be traversed along from right to left, or vice versa, to feed the work as the sewing progresses, the connection being made in the following manner, in order to so guide the cloth-plate  $a$  in its vibrating movement as to insure the stitches being made at right angles, or nearly so, to the button-hole.  $l'$  is an extension of the nut  $l$ , having a bearing on a plain part of the feed-screw  $m$ .  $l''$  is an arm, fixed adjustably to  $l'$  by a wing-nut,  $l'''$ , and stud  $l''''$ , in order to vary the positions relatively to plate  $a$  of a link,  $k$ , by which the plate  $a$  is connected to the arm  $l''$  by pivots or studs, as shown. By means of this adjustment the position of the link  $k$  can be regulated so as to guide the plate  $a$  in its vibratory movement, as required.

The object of the vibratory movement is to vary the length of the stitches, and their distance from the edge of the slit.

The longitudinal traverse of the plate  $a$  for feeding the work along is effected by the feed-screw  $m$ , which is carried at one end in the support  $b^1$ , and at the other in a slotted bearing,  $m^1$ , to permit of a lateral movement of the feed-screw  $m$ , as hereinafter mentioned. This feed-screw  $m$  receives an intermittent rotary motion from one of a pair of disks,  $n$  or  $n'$ , secured on shaft  $f$ , and having two or more pins or teeth,  $o$ , projecting from their faces. These disks  $n$  or  $n'$  are set face to face with a star-shaped pinion,  $p$ , on the end of the feed-screw  $m$ , between them, and they are placed at such a distance apart that when the pinion is placed midway between them it will not be actuated by either. The pinion  $p$  is thrown into or out of gear with teeth  $o$  by a lateral movement imparted to the feed-screw  $m$  by an eccentric,  $q$ , on rod  $c$ , through the medium of the link  $q'$ , which is attached to a tube or sleeve,  $S$ , upon the plain part of screw-rod  $m$ . The link  $q'$  is held between collars, on rod  $c$ , and the sleeve  $S$ , which slides freely on  $m$ , participates in the endwise motion of rod  $c$ . Thus, on turning said rod  $c$ , to bring one or other of the faces 1 3 of the cam  $i$  into action, the proper direction of the feed is insured by pinion  $p$  being thrown into gear with  $n$  or  $n'$ , as the case may be. When face 2 of the cam is brought into action for barring the hole there is no feed, the pinion  $p$  remaining stationary midway between the disks, as in Fig. 2.

The amount of the feed may be regulated by altering the number of pins in the disks; but this particular feature forms no part of my invention.

$m^2$  is a brake, consisting of a leather band encircling a collar fixed on screw  $m$  to prevent irregularity of feed. The said brake may be regulated by tightening the screw which unites the two ends of the leather band.

The work is secured upon plate  $a$  by means

of a clamp,  $u$ , having a slot for the needle to work through, there being a corresponding slot in plate  $a$ , both sides being necessarily of greater length than the intended button-hole, and a suitable needle-hole plate being fixed on the top of the shuttle-race beneath plate  $a$ .

The clamp  $u$  is at the extremity of an arm,  $u^1$ , which extends from the upper end of a tubular pillar,  $u^2$ , at a sufficient distance above the cloth-plate  $a$  to accommodate the work beneath it, and is bent down to the cloth-plate at the front end, as shown.

The tubular pillar  $u^2$  fits on a strong pin,  $u^3$ , firmly fixed to the cloth-plate near the back part thereof, and the clamp is secured by a nut,  $u^4$ , screwing on pin  $u^3$ .  $u^5$  is a spring-beneath pillar  $u^2$ , to raise the clamp when the nut is unscrewed.  $u^6$  is a tail-piece projecting from pillar  $u^2$  and fitting on a pin fixed on the top plate  $a$  to keep the clamp in position over the hole in plate  $a$ . 11 is the cam for driving the shuttle. 12 the hand-wheel and cam which operate the rocking lever 13 to actuate the needle.

In sewing a button-hole two parallel lines of stitches are made, the vibrating feed-plate  $a$  being caused to traverse first in one direction and then in the other by turning round cam  $i$ , each end of the intended button-hole being barred as the needle arrives thereat, after which the hole is cut.

With the cams of the shape above described the purl will be in the center of each line of stitches, the tension being so adjusted as to cause the needle-thread to lie along the top of the work with the under thread locked round it, first on one side and then on the other; but the vibrating motion of the plate  $a$  may be so regulated that the needle will enter the work twice in succession at the edge of the intended button-hole, so as to bring the purl nearer the edge instead of entering alternately at the edge of the hole and away therefrom, as is the case with the cams above described.

Figs. 7, 8, 9, and 10 show a cam-wheel,  $d$ , and three views of cam  $i$  for producing this stitch. In the latter cam the face 1 is made parallel to face 3, so that when turned round it will be inclined in the opposite direction relatively to roller  $j$ , in order that the period of rest of the vibrating plate  $a$  (necessary to allow the needle to enter twice in succession in the same line) may take place when the needle is entering the work at the edge of the intended button-hole, whichever side of the button-hole it may be sewing. In this case the circular parts of the cam-groove on  $d$  instead of being made equal, so as to bring the oblique parts  $x$   $x$  diametrically opposite one another, as in Figs. 1, 2, and 6, the one circular portion  $z$  of the cam-groove is made double the other circular portion,  $y$ , and the wheel  $d$  is so speeded that while the pin  $e^2$  on lever  $e$  is passing through the part  $z$  of the cam the vibrating plate is consequently at rest. The needle will make two descents before the plate  $a$  is again vibrated, the work

being, however, fed along between each two descents of the needle, so that it does not enter twice in the same place. In this case the proportion of wheel *d* to its driving-pinion is as three to one. It is obvious that the cam-wheel *d* may be further altered to still further modify the stitch if required.

In using this machine I find it necessary to provide means for regulating the amount of thread given out to the needle according to the class of work. For this purpose the pin 5, which actuates the quadrant or take-up 6, instead of being permanently fitted in one position on the needle-slide, is fixed on an adjustable slotted plate secured to the needle-slide by a set-screw, so that the position of the pin 5, and, consequently, the throw of the quadrant 6, can be regulated as required.

Fig. 11 shows a substitute for link *k*, for guiding the plate *a* in its vibrating motion to bring the stitches in the proper position. 7 is a slotted guide, pivoted at S to plate *a*, and secured in an oblique position by a set-screw, 9. In the slot 7 is received a pin, 10, having a small bush thereon, which slides in the slot 7. Pin 10 is fixed to the upper side of nut *l*, which in this case is without the extension *l'*. I, however, prefer the arrangement with link *k* before described. In a machine used only for fancy stitching—as for the backs of gloves, for instance—one or two faces only of the cam *i* would be required.

What I claim is—

1. In a machine for sewing straight button-holes and for fancy stitching, the combination of the inclined-faced cam *i*, the rod *c*, the cloth-plate connected thereto, and a stationary roller or stud, *j*, said rod having endwise motion, and the cam working against the roller for vibrating the cloth-plate, substantially as and for the purpose specified.

2. The combination, with the cloth-plate *a*, vibrated by cam *i*, as described, of the adjustable link *k l'*, as and for the purpose set forth.

3. The combination, with cloth-plate *a*, rod *c*, cam *i*, and link *k l'*, operated as described, of the feed-screw *m* and nut *l*, actuated as described, for imparting a vibrating, together with a traversing or feed, motion to the plate *a*, substantially as specified.

4. The combination of the connecting-link *q*<sup>1</sup> and sleeve S with the feed-screw *m*, the rod *c*, its eccentric *q*, and the cam *i*, for reversing or arresting the feed, and rendering the same dependent on the position of the cam, substantially as shown and described.

The above specification of my invention signed by me this 7th day of February, 1876.

RICHARD MATTHEW MELHUISE.

Witnesses:

WM. CLARK,  
A. W. H. EVANS.