

P. H. BAKER.
 LOCKING-LATCHES.

No. 194,637.

Patented Aug. 28, 1877.

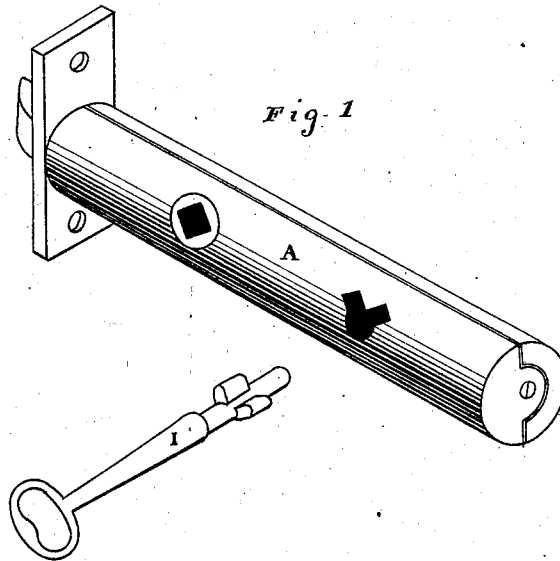

Fig. 1

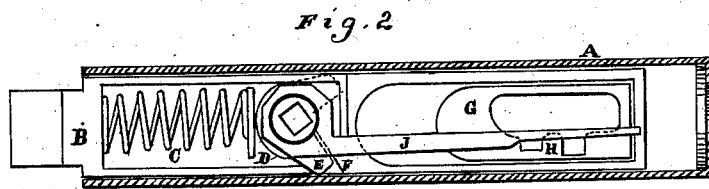

Fig. 2

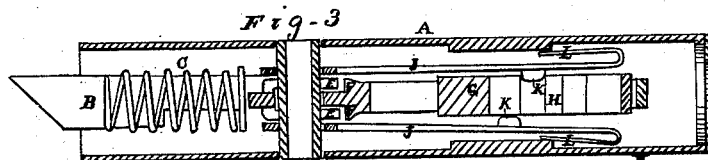
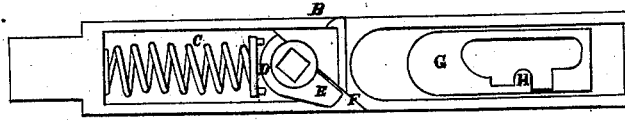
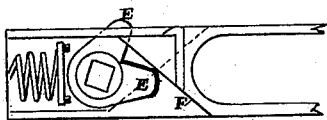

Fig. 3

Witnesses
Geo. L. Strong
Jno L. Boone

Inventor
Peter. H. Baker
 by *Dewey & Co.*
Atty.

UNITED STATES PATENT OFFICE.

PETER H. BAKER, OF VIRGINIA CITY, NEVADA.

IMPROVEMENT IN LOCKING-LATCHES.

Specification forming part of Letters Patent No. **194,637**, dated August 28, 1877; application filed March 15, 1877.

To all whom it may concern:

Be it known that I, PETER H. BAKER, of Virginia City, county of Storey, and State of Nevada, have invented an Improved Door Latch and Lock; and I do hereby declare the following to be a full, clear, and exact description thereof, reference being had to the accompanying drawings.

My invention relates to a novel construction for door latches and locks; and it consists in the construction and arrangement of devices, as will be hereinafter fully described, and pointed out in the claims.

Referring to the accompanying drawings for a more complete explanation of my invention, Figure 1 is a perspective view of my lock. Figs. 2 and 3 are views of the interior mechanism.

A is the case of my lock, which is made in the form of a cylinder of suitable size and length, the halves of the cylinder and the end plate being secured together by screws, as shown. This form of case makes it easy to fit the lock to any door by simply boring a hole into its edge of a size to just fit the case, and sinking the end plate flush with the edge, where it is secured. This saves the time and labor of mortising, as must be done for the ordinary form of lock.

The bolt and latch B is in one piece, its outer end beveled in the usual manner for such latches, while the interior portion, which moves inside the case and is guided by it, is slotted at each end, one end receiving the spiral spring C, by which the bolt is forced out, and also the cam D, which is operated by the knob to retract the bolt when it is desired to open the door. This cam has two arms, E E, standing at right angles to each other and in different planes, so that the thin flat part of the bolt at this point fits between the arms.

Two oppositely-inclined planes, F, are formed upon the opposite sides of the bolt, so that the arms E rest upon them, as shown, and when the knob is turned in either direction one or the other of the arms will act upon its inclined plane, so as to withdraw the bolt. The rear portion of the bolt is also slotted, and the slot receives the movable locking-block G.

This block is slotted, as shown, and upon one side of the slot is a projection or tooth, H, having a depression upon each side of it. Upon the sides of this tooth and the depressions the peculiar double-warded key I acts, and moves the block forward to the front of the rear slot in the bolt, where it is held in place, and thus prevents the bolt from being withdrawn.

The devices for holding the block at either end of its travel consist of two arms, J, one of which is placed at each side of the bolt, and they are kept in position by each having a hole at one end, which fits over the end of the cam D, while the arms extend along the opposite sides of the bolt.

Upon the inner face of each arm is a small projecting lug, K, one of which falls into the depression at one side of the tooth H, to hold it at one end of its travel, while the other falls into the other depression, to retain the block at the opposite end of its movement. The ends of the arms are turned over so as to form springs L, which hold the lugs to their places.

The operation will then be as follows: The block being drawn back, the bolt can be operated by the knob acting upon one of the cam-arms E and planes F, as above described. The block is retained in its position by one of the lugs K falling into the depression, as described. The double-warded key I is introduced, and when it is turned the first ward will strike the lug K, thus raising it out of the depression and freeing the block. As the key is turned the first ward falls into the nearest depression, and acting against its side moves the block forward. This movement is sufficient to prevent the bolt from being entirely retracted; but a further turning of the key causes the second ward to engage the tooth H, and carry the block forward until its front end rests against the front end of the rear slot in the bolt. At the same time the lug K, upon the opposite spring-arm J, falls into one of the depressions in the block, and thus prevents it from being moved until the lug has again been raised out of its place.

The unlocking process is a simple reversal of the locking above described.

The lock is simple, convenient, easily placed in the door, and it is effectual, and is adapted for right or left doors by simply turning over.

Having thus described my invention, what I claim as new, and desire to secure by Letters Patent, is—

1. The bolt B, having the two slots for the reception of the spring C and the locking-block G, said bolt being made reversible, and constructed with the oppositely-inclined planes F, upon which the cam-arms E act to move the bolt, substantially as herein described.

2. The slotted bolt B, movable block G, with its tooth and depressions, spring-arms J, and lugs K, said parts being fitted to be operated by the double-bitted key I, substantially as herein described.

In witness whereof I have hereunto set my hand and seal.

PETER HANSON BAKER. [L. S.]

Witnesses:

JOHN R. LOGAN,
ROBERT COCHRANE.