

W. C. BARKER.

PUMP-STOCKS AND PLUNGERS.

No. 194,639.

Patented Aug. 28, 1877.

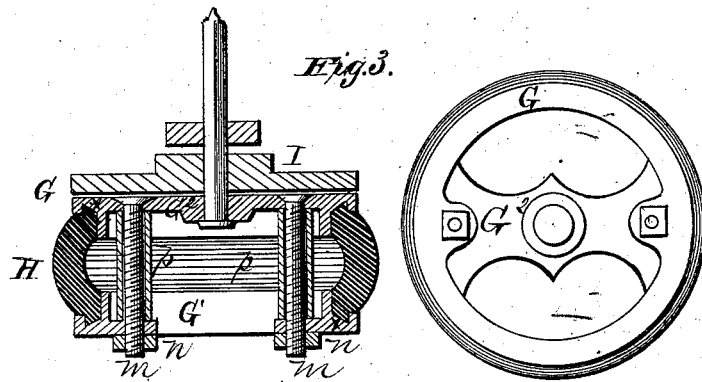
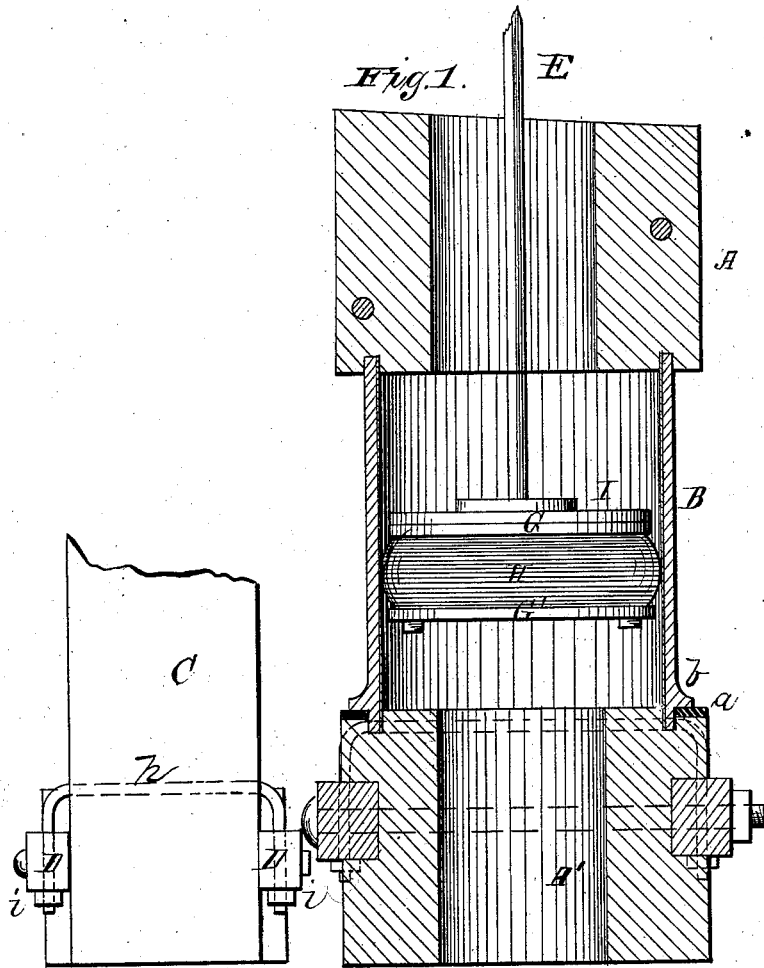

WITNESSES
Frank L. Curran
H. Aubrey Foulmer

INVENTOR
W. C. Barker
by Alexander S. ...
ATTORNEYS

W. C. BARKER.

PUMP-STOCKS AND PLUNGERS.

No. 194,639.

Patented Aug. 28, 1877.

Fig. 2.

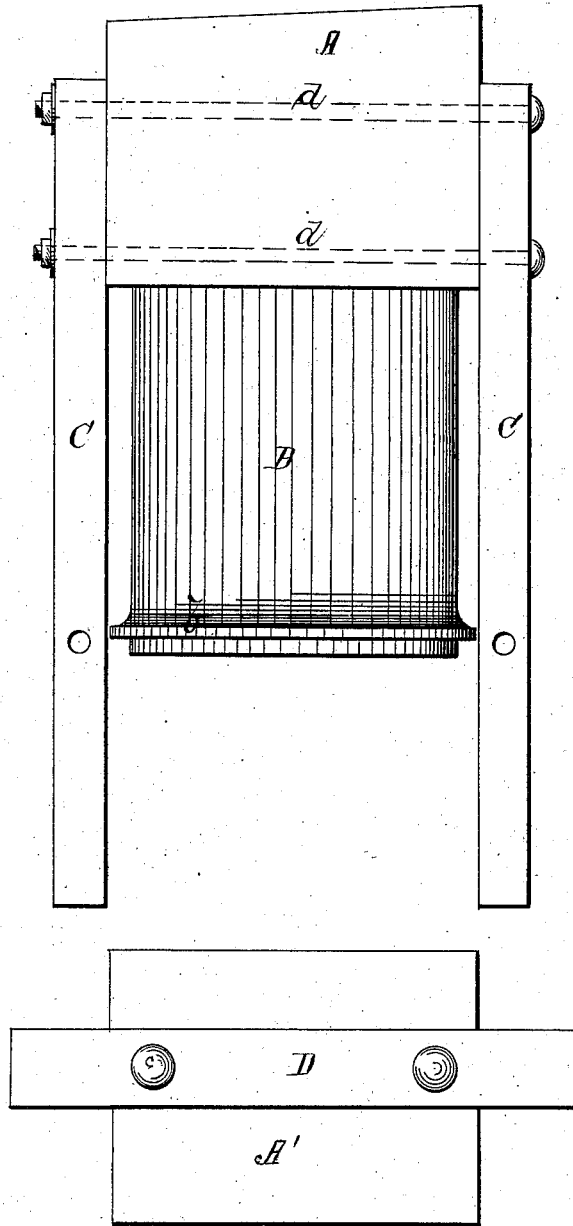

WITNESSES
Frank L. Curran
H. Aubrey Touhmin

INVENTOR
W. C. Barker
by Alexander Mason
ATTORNEYS

UNITED STATES PATENT OFFICE.

WILLIAM C. BARKER, OF HORSEHEADS, NEW YORK.

IMPROVEMENT IN PUMP STOCKS AND PLUNGERS.

Specification forming part of Letters Patent No. **194,639**, dated August 28, 1877; application filed August 17, 1877.

To all whom it may concern:

Be it known that I, WILLIAM C. BARKER, of Horseheads, in the county of Chemung, and in the State of New York, have invented certain new and useful Improvements in Pumps; and do hereby declare that the following is a full, clear, and exact description thereof, reference being had to the accompanying drawings, and to the letters of reference marked thereon, making a part of this specification.

The nature of my invention consists in the construction and arrangement of a pump, as will be hereinafter more fully set forth.

In order to enable others skilled in the art to which my invention appertains to make and use the same, I will now proceed to describe its construction and operation, referring to the annexed drawings, in which—

Figure 1 is a vertical section of my pump. Fig. 2 is a side view of the same, and Fig. 3 is a detailed view of the pump-plunger.

A A' represent two sections of the ordinary wooden pump-tubing, between which the cylinder B is clamped, as hereinafter described.

The cylinder B may be made of metal, glass, wood, or any other suitable material.

The upper end of this cylinder is inserted in a groove in the lower end of the upper stock-section A, and the lower end of the cylinder is inserted in a similar groove in the upper end of the lower section A'; but around the lower end of the cylinder B is formed a projecting flange, *b*, under which is placed a packing-ring, *a*, against the upper surface of said lower section A', to make an air-tight joint at this point. At the upper end of the cylinder no such air-tight joint is needed, though one may be applied if desired.

To the upper stock-section A, on opposite sides, are, by bolts *d d*, fastened two coupling-boards, C C, the lower ends of which fit between the projecting ends of bars D D let into the lower stock-section A', and fastened thereto by bolts *e e*.

A wire, *h*, is passed through each board C, as shown, and the ends of said wire bent downward and passed through the ends of the bars D D. Nuts *i i* are then screwed upon the ends of the wire *h*, and, by tightening

said nuts, the parts are drawn together, so as to clamp the cylinder B between the two sections A A'.

E represents the plunger-rod, attached to the plunger in any suitable manner. In the drawing I have shown the plunger made in two parts, G and G¹, both in circular form, and the upper part or ring G provided with a central cross-bar, G², in which the plunger-rod is fastened. The two parts G G¹ are connected by means of bolts *m m*, around which are placed sleeves *p p*, to hold the parts a proper distance apart, and nuts *n n*, screwed on the ends of the bolts, unite and hold the parts firmly together.

The parts G and G¹ may, however, if desired, be cast or otherwise made in one piece.

In the inner faces of the parts or rings G G¹ are made circular concentric grooves *x x*, forming bevels or inclines, as shown in Fig. 3, and in said grooves is inserted a cylinder or broad ring, H, of rubber, leather, or other suitable material, which is held or clamped between the rings in such a manner as to bulge outward and fill and fit the interior of the cylinder B.

On top of the plunger is an ordinary sliding valve, I, as shown.

When the plunger-body G G¹ is made in two parts, one part may be provided with a projecting barrel, and the other part screwed thereon, to hold and clamp the ring H.

Having thus fully described my invention, what I claim as new, and desire to secure by Letters Patent, is—

1. In combination with the stock-sections A A' and cylinder B, the coupling-boards C C, bars D D, bent rods *h h*, and nuts *i i*, all substantially as and for the purposes herein set forth.

2. A pump-plunger consisting of the rings G G¹, having circular grooves *x x*, the ring G provided with cross-bar G², and the cylinder or ring H held between them, substantially as herein set forth.

In testimony that I claim the foregoing I have hereunto set my hand this 16th day of August, 1877.

W. C. BARKER.

Witnesses:

FRANK GALT,
J. C. SCHROEDER.