

E. B. O'KELLY.
PIPE TONGS OR WRENCHES.

No. 194,716.

Patented Aug. 28, 1877.

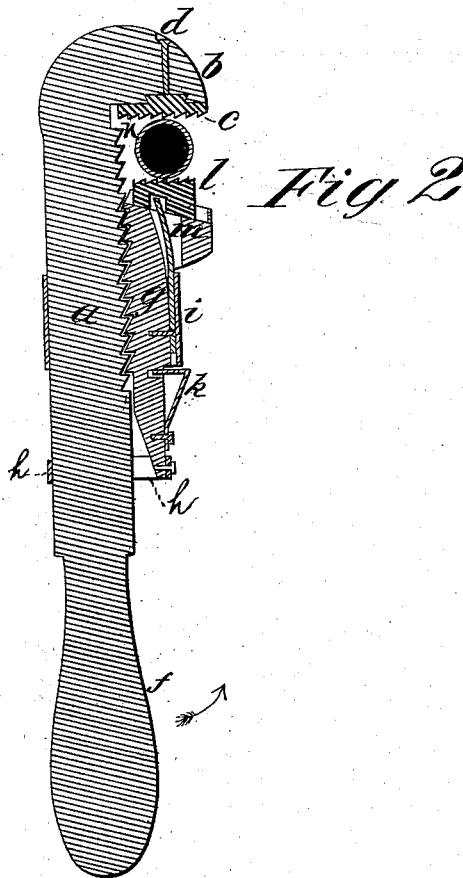
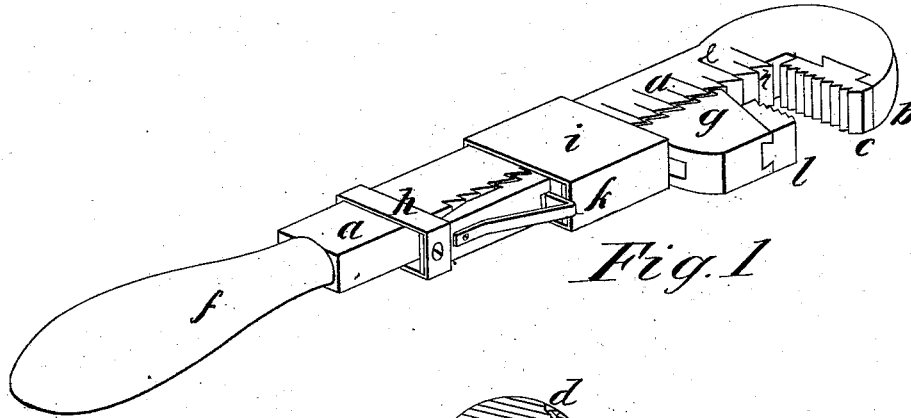

Witnesses
J. B. Connolly
G. A. Connolly

Edward B. O'Kelly Inventor

By
J. H. Miller
Attorney

UNITED STATES PATENT OFFICE.

EDWARD B. O'KELLY, OF BOSTON, MASSACHUSETTS.

IMPROVEMENT IN PIPE TONGS OR WRENCHES.

Specification forming part of Letters Patent No. **194,716**, dated August 28, 1877; application filed July 6, 1877.

To all whom it may concern :

Be it known that I, EDWARD B. O'KELLY, of Boston, in the county of Suffolk and State of Massachusetts, have invented certain new and useful Improvements in Pipe Tongs or Wrenches; and I do hereby declare that the following is a full, clear, and exact description thereof, which will enable others skilled in the art to which it appertains to make and use the same, reference being had to the accompanying drawings, and to the letters of reference marked thereon, which form a part of this specification.

The object of my invention is to obtain a better device for holding and turning pipes and round rods by an improvement of the wrenches or tongs used for that purpose.

In the accompanying drawings, Figure 1 is a perspective view. Fig. 2 is a longitudinal section.

The lever-bar *a* or shank of the wrench terminates in a fixed fulcrum, *b*, which is provided with a dovetail recess, into which is fitted a toothed jaw, *c*, made of steel or other hard metal. This jaw is also secured in place by a screw, *d*, but can be easily removed for the purpose of sharpening or replacement by a new piece when worn out. The shank is provided with a ratchet, governed by a graduated scale, *e*, the teeth being set at one eighth of an inch apart, so that the operator may readily adjust the wrench with precision to the size of the pipe to be held or turned.

The handle *f* may be cast solid with the tongs or fitted with a revolving wood handle, as usual.

The upper or sliding bar *g* is provided with ratchet-teeth engaging with those of the shank *a*, and has a fixed collar, *h*, as a guide and supporter. The sliding bar is held in position, when adjusted upon the shank, by the sliding collar *i*. This sliding collar is kept in place by the thumb-spring *k*. The face of the

sliding bar *g* is oblique to the fulcrum end of the shank, and is provided with a groove, into which is fitted a tongue and wedge-shaped serrated jaw, *l*, mounted upon the spring *m*, working within a recess in the sliding bar. This spring holds up the jaw when the wrench is not in use. When applied to the pipe the serrated teeth of the two jaws *c* and *l*, being inclined reversely to each other, take a firm gripe, the tenacity of which is increased according to the pressure applied, because of the wedge-shaped form of the jaw *l*. On the withdrawal of the pressure, and by a mere backward motion of the handle, the spring and wedge-shaped jaw acting automatically, the gripe is loosened, and the operator enabled quickly and readily to shift the wrench and take a new hold. The action of the spring forcing back the jaw when the gripe is loosened prevents the wrench from binding itself upon the pipe—a fault very common in wrenches now in use.

I claim as of my invention and desire to secure by Letters Patent—

1. In a pipe-wrench, the combination of the tongued wedge-shaped jaw *l*, mounted upon the flat spring *m*, with the sliding bar *g*, having an oblique face and groove for the jaw *l*, and recess for the spring *m*, substantially as described, and for the purposes set forth.

2. The combination of the sliding collar *i*, held in position by the thumb-spring *k*, and the fixed collar *h*, with the sliding bar and jaw, and the graduated ratchet *e*, shank *a*, and removable jaw *c*, substantially as set forth, and for the purposes indicated.

In testimony that I claim the foregoing as my own I affix my signature in presence of two witnesses.

EDWARD B. O'KELLY.

Witnesses :

WILLIAM J. KELLY,
JOHN MORIARTY.