

R. B. OSBORNE.  
SUSPENSION BRIDGES.

No. 194,717.

Patented Aug. 28, 1877.

FIG. 1.

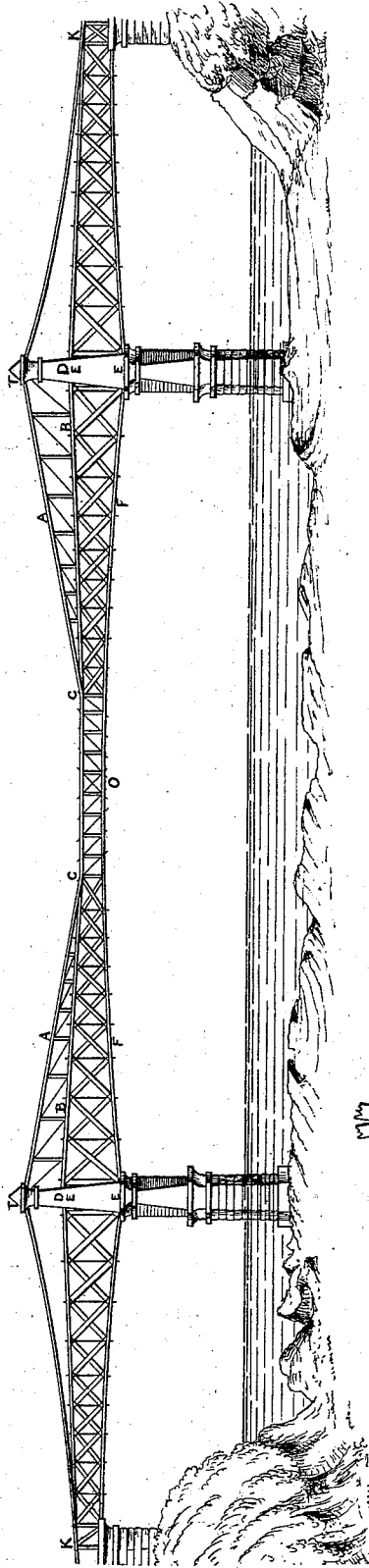

WITNESSES:  
*A. J. England*  
*Howard D. Jewell*

FIG. 3.

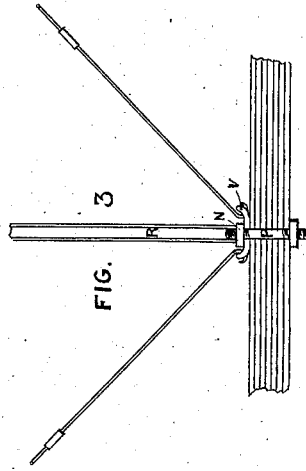
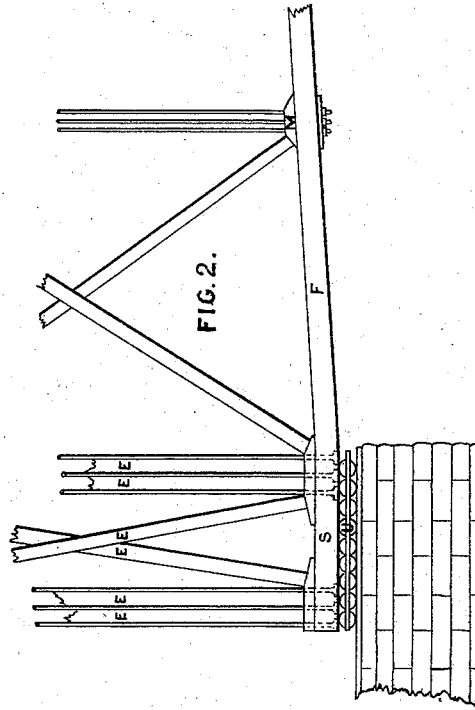

FIG. 2.



INVENTOR:  
*Richard B. Osborne*  
by *G. H. W. Howard*  
*attys.*

# UNITED STATES PATENT OFFICE.

RICHARD B. OSBORNE, OF NEW CASTLE COUNTY, DELAWARE.

## IMPROVEMENT IN SUSPENSION-BRIDGES.

Specification forming part of Letters Patent No. **194,717**, dated August 28, 1877; application filed June 30, 1877.

### *To all whom it may concern:*

Be it known that I, RICHARD B. OSBORNE, of New Castle county, Delaware, civil engineer, have invented a certain Improvement in the Construction of Bridges, of which the following is a specification, reference being had to the accompanying drawings, and to the letters of reference marked thereon.

My invention relates to means for utilizing the full power possessed by the suspension principle of bridge construction, by giving to it the vertical and lateral stiffness of the Howe truss, the lightness and elastic strength of the Pratt system, and also the known rigidity of the arch; or to combining certain systems of bridge construction in one structure, which I term my "statical suspension truss-bridge."

In the accompanying drawings, forming a part of this specification, Figure 1 is a longitudinal elevation of a bridge constructed in accordance with my invention. Figs. 2 and 3 are enlarged views of details of the invention, as hereinafter described.

Similar letters of reference indicate similar parts in all the views.

In Fig. 1 the varying heights of the truss are shown graduated to the duties incumbent on it at the several points.

A A are main chains in suspension, which are carried over towers T T on saddles, in the usual way, attached to top chords B B of the main truss at C C and also at K K on the side spans, going thence to their anchorages, in the usual manner. The secondary suspension-chains B B form the top chords of the main truss, and are carried over saddles or supports within the towers at D D. The secondary suspension-chains B B are united at the points C C, toward the center of the main span, with the main suspension-chains A A, and extend upward therefrom to the points D D within the towers below the level of the saddles of the main suspension-chains, these points being regulated by the height of truss required on the piers or abuments, which height is proportioned to the span of the bridge as controlling the height of truss at the ends thereof. The said secondary suspension-chains rest on saddles in the towers, at the lower level before mentioned, or on supports E E standing on S, a component part of

the bottom chords of said truss, as shown in Fig. 2. These secondary suspension-chains shall form the top chords, in either case, of a Howe truss, as the sustaining-truss from the piers to any designated points, as C C, near the center of the span; and are there incorporated with the primary suspension-chains, to form the top chords of a Pratt truss, for the central section of said span, so that the secondary suspension-chains are the top chords of the Howe truss up to the points C C, the primary and secondary chains being there amalgamated and united to form the continuous top chords of the Pratt trusses for the whole central section of the span. The space between C C is occupied by the central section O of the main span.

The central portion O, when used in a long-span bridge, is thus made of a different system from that used in the trusses at each end of the same, having the requisite depth of truss for its length, but being lighter in weight. It is supported at each end C C by the two systems, viz., of suspension and truss, of varying height, and is sustained, also, throughout its entire length by the main suspension-chains, its upper member being a continuation of the top chord B B of the Howe truss, and also a continuation of the main suspension-chains A A combined in one member, the strains of each being continued to the center of the span, and neutralizing each other, in whole or in part, at the point chiefly where those respective forces are at their maximum effect.

It will be seen that the catenary curve of the main suspension-chains is flattened so as to form the straight top chord of the central section O, thus directly incorporating the suspension principle of bridge construction with the well-known truss systems, by which means they act as a united whole.

The main chains A A are used from their junction at C C with top chords B B either in catenary curves or in straight lines to the tops of the towers T as the top chords of an auxiliary truss, for which the Pratt system is the most advantageous; and, further, the top members B B of the main truss are used as the bottom chords of said auxiliary truss. This is in perfect adherence with the princi-

ples before referred to for proportioning the depth of trusses to the span, and decreasing the same at the center.

The Pratt truss under this last arrangement, it will be observed, exerts a tensile strain on the chord B B, on which it stands, and at the head of each set of braces of the Howe truss, which act in compression of the same member B B, the tensile strains of the auxiliary truss and the compressive forces of the Howe truss continuing in the same member B B and through the chains A A till they reach their maximum at the center of the span O, where the sums of all the forces exerted by the suspension chains and trusses meet and neutralize each other in part or in whole. Again, it will be seen that the action of the Pratt auxiliary truss is to modify the tensile strain of the main suspension-chains A A from the towers T T to their junction with the top chord B B of the main truss at C C by an opposing compressive force, which is then carried on by the truss of the central section of the span from C to the center of the span O, thus fully accumulating a compressive force to neutralize a large portion, if not all, of the tensile strain to which chains in suspension, at their center or point of greatest deflection, are subjected.

F F is an arched bottom chord, which may be simple in form, or a truss in itself. The arched bottom chords are given more or less rise, and spring from skewbacks formed within and making parts of said bottom chords at their extreme ends, the said skewbacks being automatic in their action by movement on rollers on the piers or abutments, to compensate for the action of the arch under contraction, expansion, and loads, as far as the same is permitted by the truss, of which it is a bottom chord.

The deflection of chains in suspension and the use of the arch as a bottom chord are thus utilized to control the height of truss on the piers or abutments, and at the center of the span, as well as at the various points by which the structure is kept in its statical action. It will be seen, also, that the unnecessary weight caused by straight trusses at the center of the span (its point of greatest leverage) is dispensed with, and the strength of the structure thereby increased. The use of the arched bottom chord with the other systems of bridge construction herein described, completes in my structure a quadruple combination of the most fully-proved methods known to engineers and the builders of bridges, whereby, it is claimed, greater length of span for heavy traffic, economy of construction, and unquestionable strength, can be obtained.

S in Fig. 2 is a side view of the skewbacks for the arched bottom chord in position on the rests of the piers, and M is an elevation of an improved block by which the vertical rods of the main truss can be increased to two or more series, to obtain the required sectional area of the same.

The adjustment of the whole structure under contraction or expansion, and load, is provided for by the use of the saddles at the tops of the towers, the saddles or supports situated within the towers, over which supports the secondary suspension-chains are carried, and by the movable skewbacks S on the piers or abutments.

Fig. 3 is a plan of the mode invented by me for utilizing the nut of the steel pin of the link-joint of the chains as a block for the lateral strut in the Pratt system of lateral bracing, which mode I use for the lateral bracing of the main chains A A, and for the top and bottom lateral bracing of the central section C C of the span.

R is a cylindrical hollow column, which fits around the projecting end of the pin P and rests against the nut N screwed home on the eyelet-plate V, that receives the ends of the diagonal rods. The three lines of chains A A, B B, and F F, are thus braced laterally throughout their entire length, the main truss having its own Howe truss lateral bracing above and below.

The main chains A A, when not used as top chords for the auxiliary truss, should be about twice as far apart on the towers as they are at the central section C C, thus giving lateral stiffness to the whole structure.

Various devices have been heretofore resorted to to lessen the undulations of the floors of suspension-bridges, which, however, experience has shown are ineffectual to accomplish the result sought. This defect in the suspension system of bridge construction is remedied in my invention by constructing the sides of the bridge in the combined form and character of these trusses, which supply a large proportion of the inherent strength of the structure itself, and permit no undulations of the floor of the bridge not incident to the floors of ordinary truss-bridges.

In this invention there is found a combination of various good and well-proved systems of bridge construction in one structure, the peculiar and reliable qualities of all being concentrated, consolidated, and fully utilized—the deficiencies of one being supplied by the efficiency of others. Thus the accumulated compressive forces of the trusses at the center of the span neutralize in whole or in part the tensile strain to which the main chains are subjected as chains in suspension, and by the arrangement the heights of the main truss at its several points are duly proportioned.

By the use of a different system of truss in the central section of the span, having for its top chords a portion of the main suspension-chains where their catenary curve is flattened, the weight is decreased at the center of the span, and the compressive forces of the top chords B B of the main truss are continued to the center O of the span, where the tensile strains of the main chains in suspension are also at their maximum.

It is also observable that in this new combi-

tion, the suspension principle is united with that of the truss to sustain the ends of the central section O of the span at C C, thus making the combined powers of both systems to act as supports of increased strength and safety for the said ends, whereby the leverage exerted by long spans is greatly reduced.

By the use of the arched bottom chord abutting against movable skewbacks resting on friction-rollers on the piers or abutments, the whole structure under any moving load or under contraction or expansion is equilibrated in its strains.

This bridge, in view of the fact that in it the tensile and compressive strains to which its several members are subjected are met and neutralized by the unison of members subjected to opposite strains, is claimed as a new development of the utilization of the best properties and peculiarities of all of the most important and well-proved systems of bridge construction, and must produce desirable results in the improvement of bridges with extended spans.

I do not claim any of the separate well-known systems specified in the foregoing, or entering into the construction of my statical suspension truss-bridge; but

Having described my invention, what I claim as new, and desire to secure by Letters Patent of the United States, is—

1. The combination, in one structure, of the suspension, Howe and Pratt systems of bridge construction, arranged substantially as and for the purposes specified.

2. The combination, in one structure, of the suspension, truss, and arch systems of bridge construction, arranged substantially as and for the purposes described.

3. The secondary suspension chains B B, supported on separate saddles or on columns

standing on saddles within the towers, and forming the top chords of the main truss, combined with the main chains A A at points C C near the center of the span, substantially as herein specified, and for the purposes set forth.

4. The central section O, consisting of a truss, having for its top chords a portion of the main suspension-chains A A, flattened in their catenary curve, substantially as herein described, and for the purposes specified.

5. The central section O, combined with the end sections of the same span that embrace both the suspension and truss systems of bridge construction, whereby the ends of the central section O are sustained by the accumulated powers of the end sections at their points of connection therewith, substantially as specified.

6. In the bridge herein described, a main truss, having its top chords B supported on saddles, or columns on saddles, and its arched bottom chords F connected with movable skewbacks, resting on friction rollers on piers or abutments, substantially as and for the purposes specified.

7. The combination of the pin P, cylindrical strut R, nut N, and eyelet-plate V, substantially as and for the purposes described.

8. The block M, having an increased longitudinal width of central surface parallel with its base, whereby two or more series of rods can be used therewith, substantially as shown and described.

In testimony whereof I have hereto subscribed my name in the presence of two subscribing witnesses.

RICH. B. OSBORNE.

Witnesses:

PERCY T. OSBORNE,  
J. GODOLPHIN OSBORNE.