

J. V. PARRISH.
HORSE HAY-RAKES.

No. 194,719.

Patented Aug. 28, 1877.

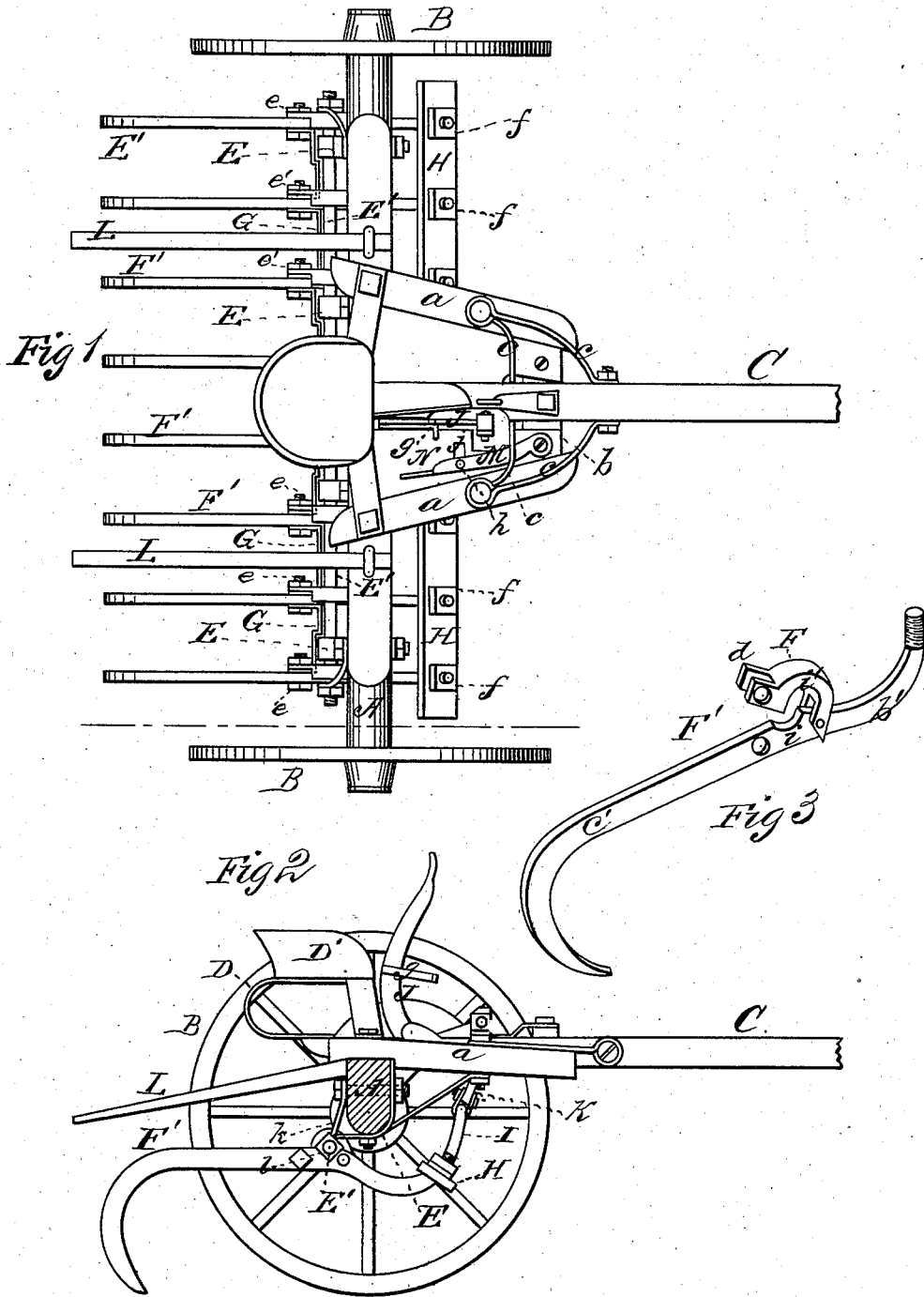

WITNESSES

Mary S. Little,
Francis J. Massi

INVENTOR

J. V. Parrish,
by Edw. Anderson,

ATTORNEY

UNITED STATES PATENT OFFICE.

JOSEPH V. PARRISH, OF UNION VALLEY, MISSOURI.

IMPROVEMENT IN HORSE HAY-RAKES.

Specification forming part of Letters Patent No. 194,719, dated August 28, 1877; application filed July 27, 1877.

To all whom it may concern:

Be it known that I, JOSEPH V. PARRISH, of Union Valley, in the county of Nodaway and State of Missouri, have invented a new and valuable Improvement in Horse-Rakes; and I do hereby declare that the following is a full, clear, and exact description of the construction and operation of the same, reference being had to the annexed drawings, making a part of this specification, and to the letters and figures of reference marked thereon.

Figure 1 of the drawings is a representation of a top view of my improved rake. Fig. 2 is a detail perspective view of a tooth or tine, and Fig. 3 is a vertical longitudinal section of the rake.

This invention has relation to improvements in horse hay-rakes.

The object of the invention is to improve this class of implements by facilitating the tripping of the rake-teeth by certain improved means for attaching and detaching the individual teeth from the head, and, finally, by an improved catch or latch that when engaged with the tripping-lever will effectually hold the teeth in the raised position.

The nature of the invention will be fully understood from the following description, and claims appended thereto.

In the accompanying drawings, the letter A designates the axle, and B the transporting-wheels. C indicates the pole, centrally bolted to the axle, and extending slightly to the rear thereof, to afford a point of attachment for the spring-support D of the driver's seat D'. The platform of the rake is composed of two rails, a, united at their front ends by means of a cross-bar, b, to which the pole is also bolted. The pole aforesaid is braced to the side rails a by metallic rods c c, in order to sustain it against lateral strain. E represents angular metallic plates that are bolted to the front vertical face of the axle, and extend under it slightly to the rear of the same. They are provided upon their rear ends with horizontal bearings, in which is rigidly secured a metallic shaft, E', upon which the rake-teeth vibrate vertically.

The rake-teeth designated in the drawings by the letter F' are levers of the first degree or order—that is, they are fulcrumed on shaft

E' at a point between their ends. They are of the following description: They consist of a tine, c', of the usual description, having a depressed concave shank, b', and a half-bearing, i, upon its upper edge in front of said shank. The other bearing i' is formed in the under side of a curved metallic lock-plate, F, having a projecting bifurcated offset, d, that straddles the tine, and is provided with perforations registering with a corresponding perforation in the body of the tine in front of the lower half-bearing. The tooth is applied to shaft E' by passing it under the same until its half-bearing receives said shaft. The lock-plate is then swung over shaft E', and secured to the tine of the tooth by a bolt, e, passing through the registering perforations in the offset d and said tine.

The teeth are spaced and held at a proper distance apart by means of L-shaped metallic plates G, having perforations in their ends by means of which, and the bolts e aforesaid, they are secured to the teeth.

In practice these bolts will have a nut, e', upon their ends, but if I so elect I may substitute an ordinary screw-bolt.

The front ends of the teeth are provided with a screw-threaded rabbet that extends through a rake-head, H, and is secured thereto by means of a nut, f. The teeth are thus secured to the carriage in such manner that, should one or more of them become injured or broken, it may be removed without disturbing the balance by removing bolt e' and detaching the nut f.

I represents an operating-crank that is rigidly secured to the rake-head, and connected to a bell-crank lever, J, having its fulcrum on the pole by means of a pitman, K. When this lever is thrown to the front the rake will be raised from the ground, and its load discharged by the usual strippers L. In order to hold the rake in this position, lever L is provided with an angular arm, g, with which a horizontally-vibrating latch, M, is adapted to engage. This latch is pivoted at its front end to the platform, and extends rearwardly within convenient reach of the driver's seat. It vibrates above a metal plate, N, rigidly secured to the platform, and is prevented from upward displacement when subjected to strain by a

bolt, *h*, extending upward through a curved slot, *j*, in said plate, and secured to said latch. The rake-teeth are secured upon the shaft *E'* by means of hangers *k* secured to the axle, and provided upon their free ends with an eye engaging the ends of said shaft. A nut, *l*, is then screwed upon each end of said shaft, and the teeth are then properly secured.

What I claim as new, and desire to secure by Letters Patent, is—

1. The combination, with the horizontal shaft *E'* and the rake-teeth removably secured and vibrating thereon, of the \perp -shaped spacing-plates *G*, interposed between the said teeth and the bolt *e*, securing them thereto, substantially as specified.

2. The combination, with the shaft *E'* and the rake-teeth vibrating thereon, of the spacing-plates *G*, the hangers *k* engaging said shaft, and the nuts *l* applied thereon at its ends, substantially as specified.

3. The combination, with the shaft *E'*, of the rake-teeth *F'*, having a half-bearing, *i*, the vibrating locking-plate *F*, having the half-bearing *i'*, the \perp -shaped spacing-plates *G*, and the bolts *e*, securing the locking-plates and the spacing-plates to the rake-teeth, substantially as specified.

4. The combination, with the rake-tooth *F'*, having a half-bearing, *i*, of the vibrating locking-plate *F*, adapted to be clamped around the journal-shaft, and secured to the body of the tooth, substantially as specified.

5. The rake-tooth for horse hay-rakes, consisting of the tine *c'*, and a vibrating bearing-plate *F*, adapted to be secured to the body of the tine, and to form therewith an eye for the reception of the journal-shaft, substantially as set forth.

6. The combination, with the journal-shaft *E'* and the rake-teeth fulcrumed thereon, and extending in front of the axle, of the rake-head *H*, having crank-arm *I*, the pitman *K*, the bell-crank tripping-lever *J*, having latch-arm *g*, and the horizontally-vibrating latch *M*, adapted to engage said arm, substantially as specified.

In testimony that I claim the above I have hereunto subscribed my name in the presence of two witnesses.

JOSEPH VOGAN PARRISH.

Witnesses:

HENRY TAEL,

W. C. MOREHOUSE.