

J. H. SNYDER & D. W. HENDERSON.  
BUGGY-TOPS.

No. 194,739

Patented Aug. 28, 1877.

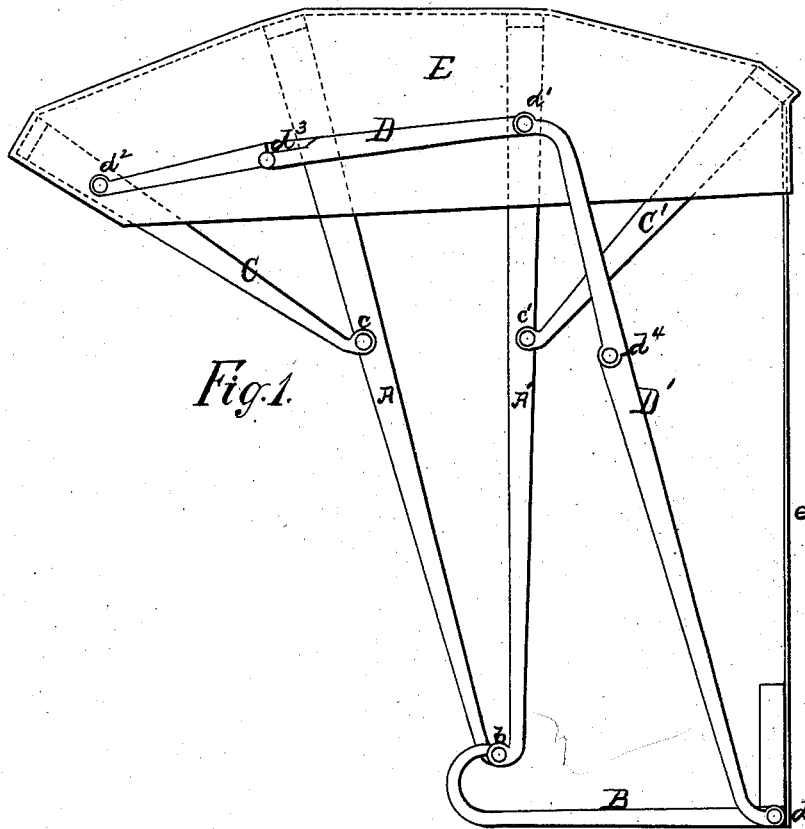

Fig. 1.

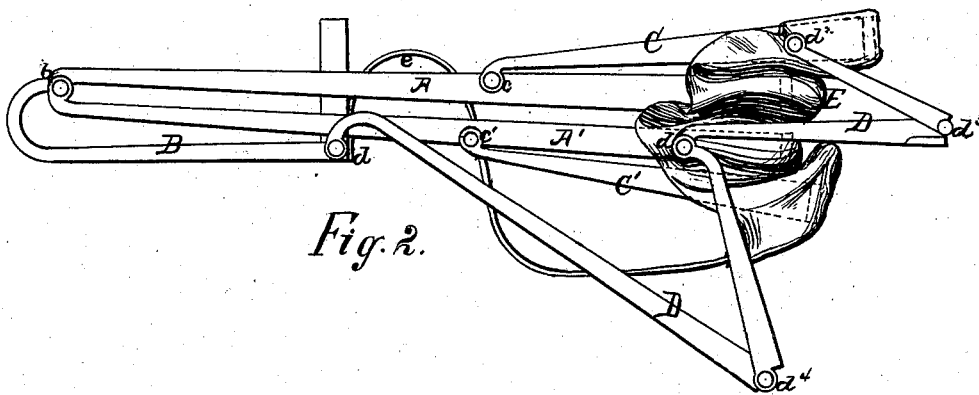

Fig. 2.

Witnesses:

Theodore Meester,  
B. F. Clark

Inventors

John H. Snyder  
David W. Henderson

By Wich & Wich  
Attys.

# UNITED STATES PATENT OFFICE.

JOHN H. SNYDER AND DAVID W. HENDERSON, OF MUSKEGON, MICHIGAN.

## IMPROVEMENT IN BUGGY-TOPS.

Specification forming part of Letters Patent No. 194,739, dated August 28, 1877; application filed May 31, 1877.

### *To all whom it may concern:*

Be it known that we, JOHN H. SNYDER and DAVID W. HENDERSON, of Muskegon, county of Muskegon in the State of Michigan, have invented an Improvement in Buggy-Tops, of which the following is a full, clear, and exact description, reference being had to the accompanying drawings, forming part of this specification.

Our invention consists in the combination, with the main or central bows of a buggy-top frame, of front and rear short brace bows, the said short bows being respectively pivoted to or upon the said main bows at such a point that when the buggy-top is folded back or lowered the front and rear short bows will pass entirely back of the seat of the buggy, and thus remove all the bows from liability of contact with the arms or persons of the occupants of the buggy, as hereinafter particularly set forth.

Figure 1 is a side elevation of a buggy-top embodying our invention, showing the top spread. Fig. 2 is a similar view of the same, showing the top folded back.

We construct the frame of our buggy-top with the two main bows A and A', which are pivoted to the rail B at b, as shown, and are located centrally in the frame. Upon the front main bow A we arrange the brace-bow C, pivoting it at each end to the respective sides of the said main bow, as shown at c. Upon the rear main bow A' we arrange the brace-bow C', pivoting it at each end to the respective sides of the said main bow, as shown at c'. To fully carry out the purposes of our invention these joints c and c', where the brace-bows meet the main bows, should be at such a point on the main bows that when the top is folded back, as shown in Fig. 2, the short or brace-bows C and C' will pass entirely back of the seat of the vehicle, and said joints should, therefore, be at least such a distance

on the main bows from the joint thereof with the rail B, as will be equal to the distance from said joint b to the back of the seat. It is preferable, however, that the said joints c c' should be at a point on the main bows at a somewhat greater distance than that mentioned, as shown in the drawings.

The side braces which we employ to hold the top spread we form as shown at D D', pivoting them to the rail at the back at d to the rear main bow at d<sup>1</sup>, and to the front brace bow at d<sup>2</sup>, with joints d<sup>3</sup>, back of the front brace bow, and d<sup>4</sup>, below the rear main bow.

Now, it is evident that when the frame thus constructed, is covered with the top E, and is provided with the back-stays e, and is spread as shown in Fig. 1, the front brace-bow will extend the top sufficiently forward, and the bows will not offer any obstruction in entering or leaving the vehicle, while, at the same time, when the top is folded back and lowered, the bows C and C' will pass entirely back of the seat of the vehicle and the main bows A A' will fold closely together at the rail, and all the bows be then entirely removed from liability of contact with the arms or persons of the occupants of the vehicle.

What we claim as our invention, and desire to secure by Letters Patent, is—

In a buggy-top frame the combination, with the main central bows A A', of the short brace bows C C', when the latter are respectively pivoted upon the former at c c', at such a point that when the top is folded back or lowered the bows C C' will pass entirely to the rear of the buggy-seat, as and for the purposes specified.

JOHN H. SNYDER.  
DAVID W. HENDERSON.

Witnesses:

DAVID D. ERWIN,  
FRED. W. THOMPSON.