

C. D. WALLACE.  
DROP-HAMMERS.

No. 194,747.

Patented Aug. 28, 1877.

Fig. 1

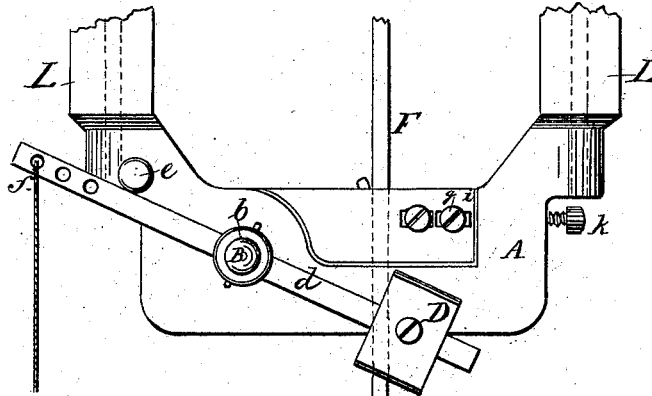

Fig. 2

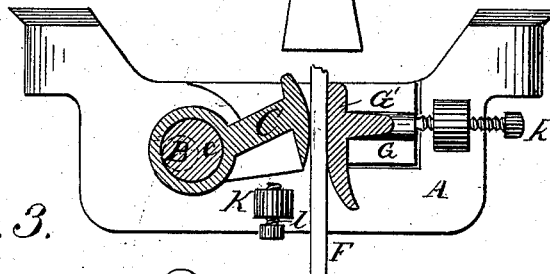
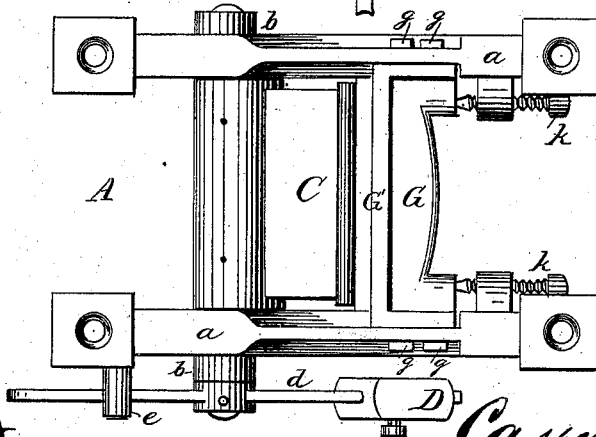

Fig. 3.



Attest:  
M. S. Ditmer.  
Jno. P. Brooks.

Inventor:  
Casper D. Wallace  
by Louis Baggett  
Attorney.

# UNITED STATES PATENT OFFICE.

CASPER D. WALLACE, OF AUBURN, NEW YORK.

## IMPROVEMENT IN DROP-HAMMERS.

Specification forming part of Letters Patent No. **194,747**, dated August 28, 1877; application filed March 12, 1877.

*To all whom it may concern:*

Beit known that I, CASPER D. WALLACE, of Auburn, in the county of Cayuga and State of New York, have invented certain new and useful Improvements in Friction-Holding Devices; and I do hereby declare that the following is a full, clear, and exact description thereof, which will enable others skilled in the art to which it appertains to make and use the same, reference being had to the accompanying drawings, which form a part of this specification, and in which—

Figure 1 is a side elevation. Fig. 2 is a vertical longitudinal section; and Fig. 3 is a top plan.

Similar letters of reference indicate corresponding parts in all the figures.

This invention relates to that class of devices which are used for holding the drops of trip or drop hammers in suspension until released by the operator; and it consists in the construction and combination of parts hereinafter more fully shown and described.

In the drawing, A is the frame of my improved device. This consists of two side pieces, *a a*, having boxes or bearings *b b* for the shaft B, which is an eccentric, the swell of which, *c*, is located between the side pieces *a a*. C is a friction-latch, which is pivoted, as shown, upon the swell of shaft B, upon which it works loose and independently. One of the ends of shaft B projects through side piece *a*, where it has a lever, *d*, having at one end an adjustable weight, D, which forces the opposite end of lever *d* up against a stud, *e*, projecting from side piece *a*. To the end of lever *d*, resting against a stud, *e*, is secured a rope or rod, *f*, which is within easy reach of the operator, who is standing below, and which may, if desirable, be operated by a treadle or other convenient device.

G is a cross-piece or brace, which is secured between side pieces *a a*, which are held together by it and the shaft B. The cross-piece G is adjustable laterally, the screws *g g* which hold it in place working in slots *i i* in side pieces *a a*, and its face G' may thus be adjusted at any desired distance from the face of latch C, so as to conform to the thickness of the plank or strap F, carrying at its end

the drop or hammer. Set-screws *k k* work against the end of cross-piece G, so as to prevent it from being forced out of position by the pressure upon it.

The insides of side pieces *a a* have studs or brackets K K, in which are set-screws *l l*, that work against the under side of latch C, which is thus prevented from falling or swinging down between side pieces *a a* when the drop is released.

L L in the drawings are the timbers under which my device is secured, and above or below these is the lifting mechanism. This, which may be of any desired character, is not shown in the drawing.

The operation and advantages of my invention will be readily understood from the foregoing description, and by reference to the drawings hereto annexed. When the drop is lifted by the mechanism above or below the timbers L L, the strap or plank F slides easily between the faces of latch C and cross-piece G, the former of which, as before stated, is pivoted loosely upon shaft B, the eccentric or "swell" of which, of course, faces the cross-piece G, as shown in the drawing, in which position it is retained, when the apparatus is at rest, by the weight D upon lever *d*. When the plank F has been lifted to the desired height, and is released by the lifting mechanism, the latch C forces it, impelled by its own weight and that of the hammer attached to it, against the face of cross-piece G, between which and the face of latch C it is held securely by friction. In order to release it, for the purpose of letting it drop, it is only necessary to pull the rope or rod *f* attached to lever *d* either by hand or by means of a treadle. This will turn the shaft B in such a manner as to bring the swelled portion *c*, and with it the latch C, which is pivoted thereupon, back from cross-piece G, thus increasing the distance between the faces of this and latch C, and consequently permitting plank F to drop. The front of latch C follows the plank F with a downward motion until it reaches the set-screws *l l*, upon which it slides with a purely backward motion to the extent of the operation of lever *d*. This downward motion of latch C, when drawn back to release the drop,

while in no way impeding the fall of this, is calculated to ease and steady it, and prevent it from vibrating.

The principal advantages of my invention are the facility with which the cross-brace G may be adjusted, so as to accommodate a plank or strap of any thickness, and the ease with which the drop is operated, this latter being due to the latch C being pivoted loosely upon the eccentric shaft B.

It is obvious that my invention may be subjected to a variety of minor changes without changing its character. Thus, for instance, a spring or other device may be employed to hold the lever *d* in position, instead of the adjustable weight D. The faces of cross-piece G and latch C may be made plain, corrugated, or serrated, and other similar changes may be made.

Having thus described my invention, I claim and desire to secure by Letters Patent of the United States—

1. The combination of the laterally-adjustable cross-piece G, side pieces *a a*, having slots

*i i*, and set-screws *k k*, substantially as and for the purpose herein shown and specified.

2. The side pieces *a a*, having studs or brackets K K, provided with set-screws *l l* or their equivalent, in combination with the latch C, pivoted loosely upon the eccentric shaft B, substantially as and for the purpose herein set forth.

3. The improved friction-holding device herein described, consisting, essentially, of the side pieces *a a*, laterally-adjustable cross-piece G, set-screws *k k*, eccentric shaft B, lever *d*, having weight or spring D, loose pivoted latch C, and set-screws *l l*, all combined and arranged to operate substantially in the manner and for the purpose herein shown and specified.

In testimony that I claim the foregoing as my own I have hereto affixed my signature in presence of two witnesses.

CASPER D. WALLACE.

Witnesses:

THOMAS VORCE,  
WILLIAM J. ELLIS.