

J. FERGUSON.

MACHINES FOR CUTTING HORSESHOE NAIL-BLANKS.

No. 194,767.

Patented Sept. 4, 1877.

Fig. 1.

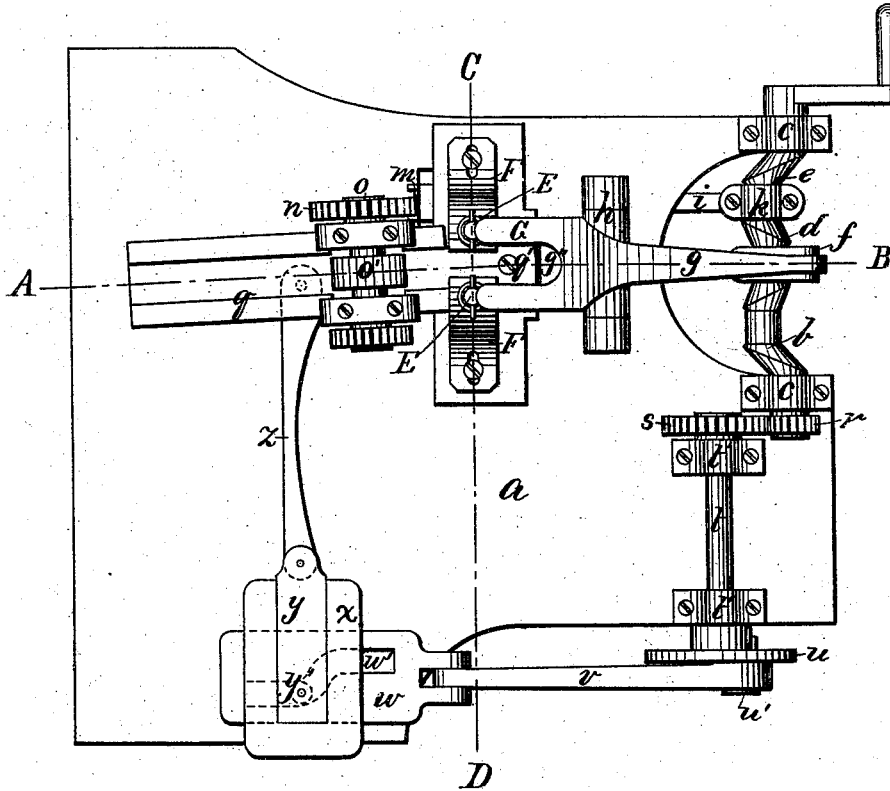

Fig. 4.



Witnesses:

Henry Chadbourn.  
A. Torrey

Inventor:

James Ferguson  
by  
Alvan Audreus  
his atty.

J. FERGUSON.  
MACHINES FOR CUTTING HORSESHOE NAIL-BLANKS.  
No. 194,767. Patented Sept. 4, 1877.

Fig. 2.

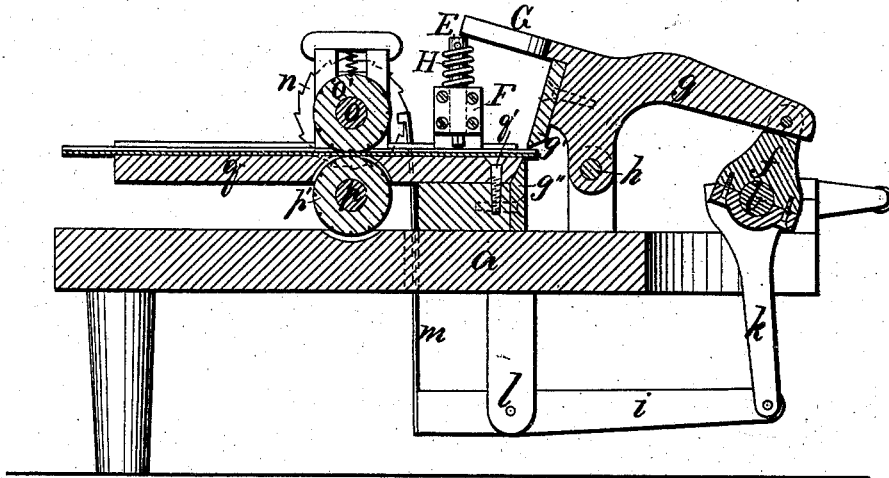
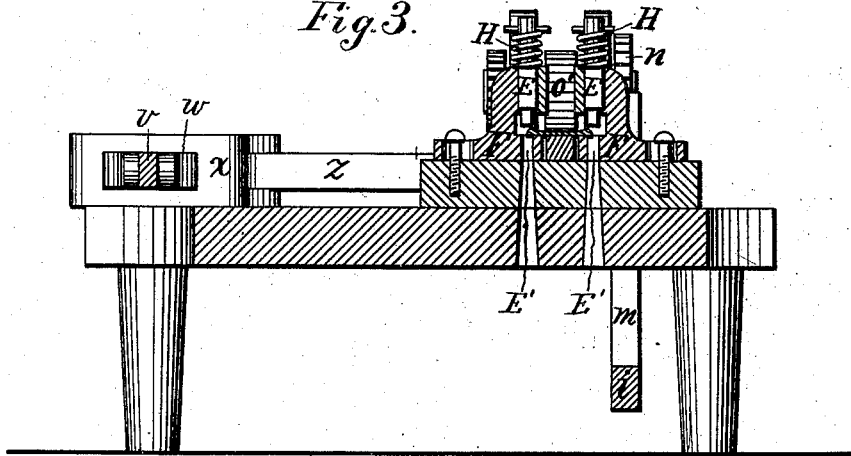

Fig. 3.



Witnesses:

Henry Chadbourn  
A. Torrey

Inventor:

James Ferguson  
by  
Alvan Audrain.  
his atty.

# UNITED STATES PATENT OFFICE.

JAMES FERGUSON, OF BRIDGEWATER, MASSACHUSETTS, ASSIGNOR OF TWO-THIRDS HIS RIGHT TO JOHN TURNER AND JAMES H. FERGUSON, OF SAME PLACE.

## IMPROVEMENT IN MACHINES FOR CUTTING HORSESHOE-NAIL BLANKS.

Specification forming part of Letters Patent No. 194,767, dated September 4, 1877; application filed June 5, 1877.

To all whom it may concern:

Be it known that I, JAMES FERGUSON, of Bridgewater, in the county of Plymouth and State of Massachusetts, have invented certain new and useful Improvements in Machines for Cutting Horseshoe-Nail Blanks; and I do hereby declare that the following is a full, clear, and exact description thereof, which will enable others skilled in the art to which it appertains to make and use the same, reference being had to the accompanying drawings, and to the letters of reference marked thereon, which form a part of this specification.

My invention relates to improvements in machines for cutting horseshoe-nail blanks.

It consists, in combination with a shearing apparatus for the purpose of cutting off the nail-blanks from the nail-plate, of a pair of adjustable punches located near the edges of the nail-plate, which is fed between them to the shearing apparatus, for the purpose of cutting out notches or recesses on both opposite edges of the nail-plate, by which the nail-blanks cut off from such a prepared plate are better adapted for their subsequent insertion between the grippers in which the heads and shanks of the nails are shaped. These punches may be arranged so as to descend and rise together, or they may be arranged so as to work independent of each other, as may be required, without departing from the spirit of my invention.

The nail-plate is fed by means of rollers, on an oscillating way, toward the punches and shears, and the nail-plate remains at rest when the punches and shears perform their work, during which time the feed-rollers are held stationary.

On the accompanying drawings, Figure 1 represents a plan view of my improved machine. Fig. 2 represents a longitudinal section on the line A B, (shown in Fig. 1;) and Fig. 3 represents a cross-section on the line C D, also shown in Fig. 1. Fig. 4 represents a plan view of the nail-plate with its notches.

Similar letters refer to similar parts wherever they occur on the different parts of the drawings.

*a* represents the frame of a cutting-machine constructed in the ordinary way. *b* represents

the driving-shaft, movable in the bearings *cc*, and provided with cranks *d e*, the former connected to the link *f*, for the operation of the shear-frame *g* on the fulcrum *h*, and the latter connected to the rocking lever *i* by means of the link *k*, as shown. The lever *i* is hung on the fulcrum *l*, and is provided with the pawl-bar *m*, the upper end of which engages into the teeth on the ratchet-wheel *n* that is secured to the upper roller-shaft *o*. *o'* represents the upper feed-roller, secured to the shaft *o*, and *p'* represents the lower feed-roller, secured to the shaft *p*, movable in suitable bearings on the swinging nail-plate guide *q*, that is moved laterally forward and back on its fulcrum-pin *q'*. The upper and lower feed-rollers *o' p'* are geared together by means of spur-gears in the usual way. *r* represents a pinion secured to the driving-shaft *b*, and engaging into the spur-gear *s* secured to the intermediate shaft *t*, that is movable in stationary bearings *t' t'*.

To the outer end of said shaft *t* is secured a disk, *u*, having a crank-pin, *u'*, to which is jointed the connecting-rod *v*, the rear end of which is hinged to the traversing-block *w*, provided with a curved slot, *w'*. The block *w* is movable in the stationary guide *x*, that also serves as a guide for the traversing-block *y*, having a pin, *y'*, projecting through the curved slot *w'*, as shown in dotted lines in Fig. 1. The link *Z* connects the traversing-block *y* to the swinging nail-plate guide *q*, and in this manner a swinging motion is imparted to the said nail-plate-guide *q* from the driving-shaft *b*, for the purpose of presenting the nail-plate to the action of the shears, so as to be cut off in a manner as shown in dotted lines in Fig. 4.

To the shear-frame *g* is secured the movable shearing-jaw *g'*, and to the frame *a* is secured the stationary jaw *g''*, in the ordinary way.

*E E* represent the adjustable punches, operated up and down in the adjustable frames *F F*. These punches are arranged and operated on the opposite sides of the nail-plate, for the purpose of cutting or punching notches on the edges of the nail-plate, as represented in Fig. 4. Each punch is provided with its corresponding die *E' E'*, and the punches are shown as being operated by means of the pro-

jecting levers G G on the shearing-frame *g*, or a separate lever may be used for each punch, independent of the other, when it is desirable not to operate both punches at the same time. Springs H H are shown on the punches E E, for the purpose of automatically raising them above the nail-plate as soon as the levers G G cease to act upon them.

The frames F F are made adjustable to and from each other, as well as sidewise, for the purpose of being able to cut or punch the notches from the nail-plate in the exact and desired positions.

I may, of course, use a shear having a linear vertical motion, instead of a rocking motion, without departing from the spirit of my invention.

What I wish to secure by Letters Patent, and claim, is—

The combination, with the oscillating nail-plate guide *g* and its shearing apparatus *g g'*, of the adjustable punches E E F F, for the purpose of punching notches on the edge of the nail-plate previous to its being cut by the shears, as herein shown and described.

In testimony that I claim the foregoing as my own invention I have affixed my signature in presence of two witnesses.

JAMES FERGUSON.

Witnesses:

ALBAN ANDRÉN,  
HENRY CHADBOUEN.