

M. L. HOWARD.  
WIND-MILLS.

No. 194,822.

Fig. 1.

Patented Sept. 4, 1877.

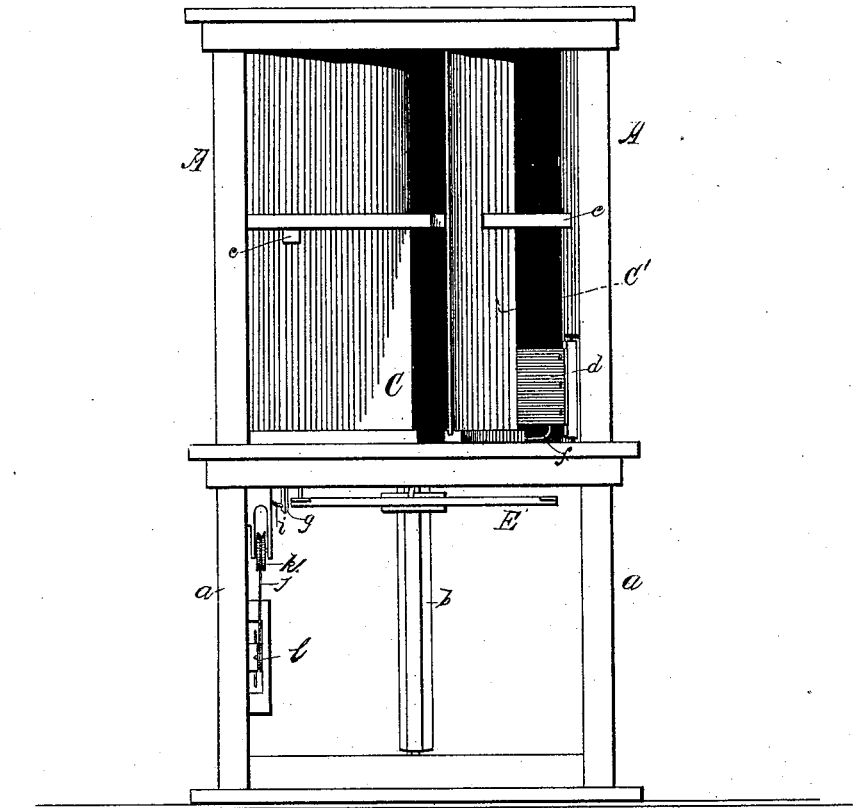
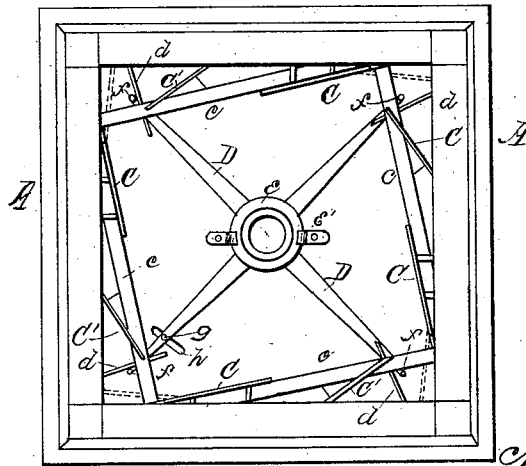

Fig. 2.



WITNESSES

*Arthur H. Adams.*  
*John W. Miller.*

*Martin L. Howard*  
INVENTOR

*Edson Brothers*

ATTORNEYS

M. L. HOWARD.  
WIND-MILLS.

No. 194,822.

Patented Sept. 4, 1877.

Fig. 3.

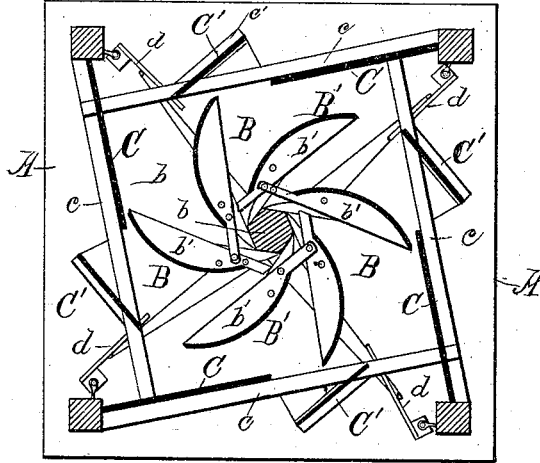

Fig. 4.

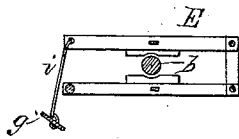

Fig. 5.

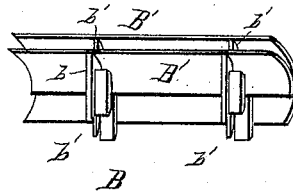
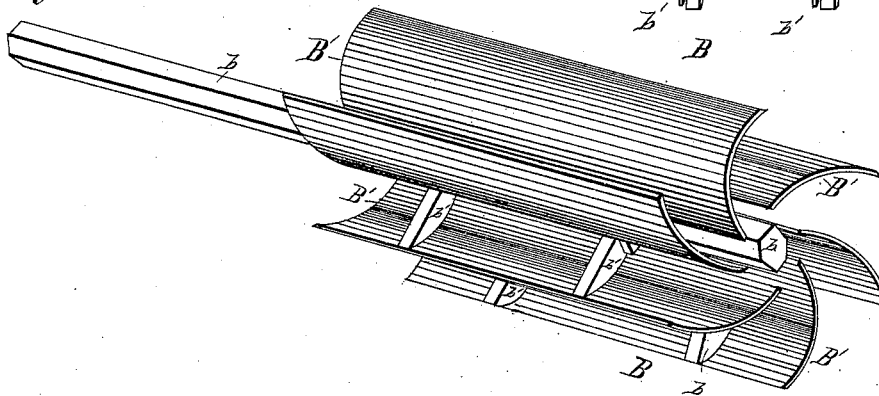

Fig. 6.



WITNESSES

*Arthur W. Adams*  
*Dr. W. H. Miller*

*Martin L. Howard*  
INVENTOR

*Edwin Brooker*

ATTORNEY

# UNITED STATES PATENT OFFICE.

MARTIN L. HOWARD, OF CLEAR LAKE, IOWA.

## IMPROVEMENT IN WINDMILLS.

Specification forming part of Letters Patent No. 194,822, dated September 4, 1877; application filed July 10, 1877.

*To all whom it may concern:*

Be it known that I, MARTIN L. HOWARD, of Clear Lake, in the county of Cerro Gordo and State of Iowa, have invented certain new and useful Improvements in Windmills; and I do hereby declare that the following is a full, clear, and exact description thereof, which will enable others skilled in the art to which it appertains to make and use the same, reference being had to the accompanying drawings, and to the letters of reference marked thereon, which form a part of this specification, and in which—

Figure 1, Sheet 1, is a side elevation of my improved wind-wheel. Fig. 2 is a plan view with the wheel removed. Fig. 3, Sheet 2, is a horizontal section thereof. Fig. 4 is a detached plan view of the brake. Fig. 5 is a detached perspective view of a pair of the vanes of the wheel proper, and Fig. 6 is a similar view of the wheel proper itself.

Corresponding parts in the several figures are denoted by like letters.

This invention relates to certain improvements in wind-wheels; and it consists, first, of the peculiar construction of the wheel proper; secondly, in the employment of chutes arranged with a view to obtaining the full force of the wind upon the wheel; and, thirdly, of brake mechanism, substantially as hereinafter more fully set forth.

In the annexed drawings, A A refer to a frame or inclosure supported upon uprights or posts *a a*. B refers to the wheel proper, its axis or shaft *b* bearing in the top of the inclosure A A, and passing down through the bottom thereof, and bearing, at its lower end, in a suitable support or cross-piece. To this axis or shaft are secured curved radial vanes B' B', in the manner hereinafter described, so as to allow the wind striking and entering between the vanes upon one side of the wheel to pass through the wheel and strike the vanes upon the opposite side of the wheel, and thus accelerate its speed, the vanes being curved and arranged, as clearly shown in Figs. 3 and 6, to combine with their manner of attachment in bringing about that result.

The vanes or wings B' B' are preferably put together in pairs, and so as to provide

spaces between each other, one of the transverse uniting-pieces *b' b'* of a pair being fastened to the other, and it to the shaft or axis *b*, so as to leave a space around the said shaft or axis, as seen in Fig. 6, for the purpose before mentioned.

C C' are chutes in each side of the inclosure A, and consisting each of two boards projecting inwardly, and disposed a suitable distance apart, and at such an angle with each other as to direct the full force of the wind in upon the wheel from whichever quarter it may be blowing. These chutes are braced in position at about midway their length, as at *c c*.

*d d* are wings or vanes, hinged or pivoted to the uprights of the frame or inclosure A.

D D are arms or bars radiating from a ring, *e*, confined to the bottom of the frame or inclosure A A, around the axis or shaft of the wheel, and, preferably, beneath plates *e' e'*, fastened to the said bottom. The free ends of these arms or bars are turned upwardly, as at *f f*, for the vanes or wings *d d* to bear against as the latter are exerted upon by the wind to rotate the said arms or bars, which in turn apply the brake, presently described, to regulate the motion or power of the wheel. A bar or pendant, *g*, depends from one of the arms or bars D D through an elongated slot, *h*, in the bottom of the inclosure A, and is connected by a rod, *i*, or other suitable medium to the frame or brake E, disposed so as to bear upon the shaft or axis *b*, as seen in Figs. 1 and 4, and depending from the bottom of the inclosure A. The free end of one of the bars of the frame or brake E, to which is attached one end of the rod *i*, has also attached to it a cord or rope, *j*, passing down over a pulley, *k*, secured to one of the posts, and connecting with a windlass, *l*, likewise secured in position. This is an additional means for, or another way of, applying the brake.

Having thus described my invention, what I claim, and desire to secure by Letters Patent, is—

1. The wheel B B, consisting of the curved radial arms or wings B' B', put together in pairs, and connected to the axis or shaft *b* of the wheel by the bars *b' b'*, one of the bars *b' b'* connecting a pair of wings together, being

connected to the other bar of said pair of wings, substantially as and for the purpose set forth.

2. The wheel B, having the curved radial wings or vanes B' B', arranged with reference to each other and the axis of the wheel, as described, in combination with the inclosure A, having the chutes C C', arranged as set forth, substantially as and for the purpose set forth.

3. The vanes or wings *d d*, in combination with the radial arms or bars D D *ff*, pendant

*g*, rod *i* or its equivalent, brake E, and wheel-axis or shaft, substantially as and for the purpose set forth.

In testimony that I claim the foregoing as my own I hereunto affix my signature in presence of two witnesses.

MARTIN L. HOWARD.

Witnesses:

JOHN T. LATTIMORE,  
O. R. SIMENSON.