

G. W. ROBAUGH.
PUMPS.

No. 194,843.

Patented Sept. 4, 1877.

Fig. 1

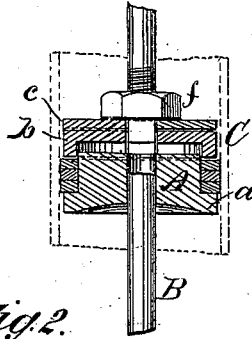

Fig. 2

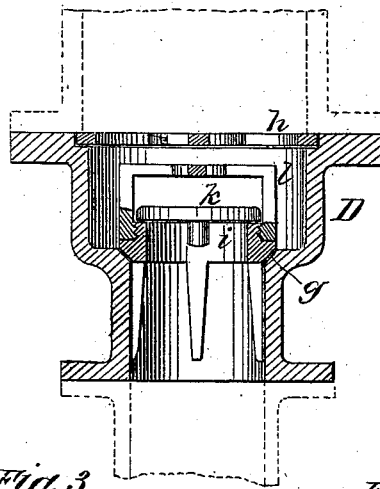

Fig. 3

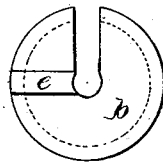
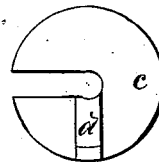

Fig. 4



WITNESSES:

Francis McArdle
J. H. Scarborough.

INVENTOR:

G. W. Robaugh
BY *Munroe*

ATTORNEYS.

G. W. ROBAUGH.
PUMPS.

No. 194,843.

Patented Sept. 4, 1877.

Fig. 5.

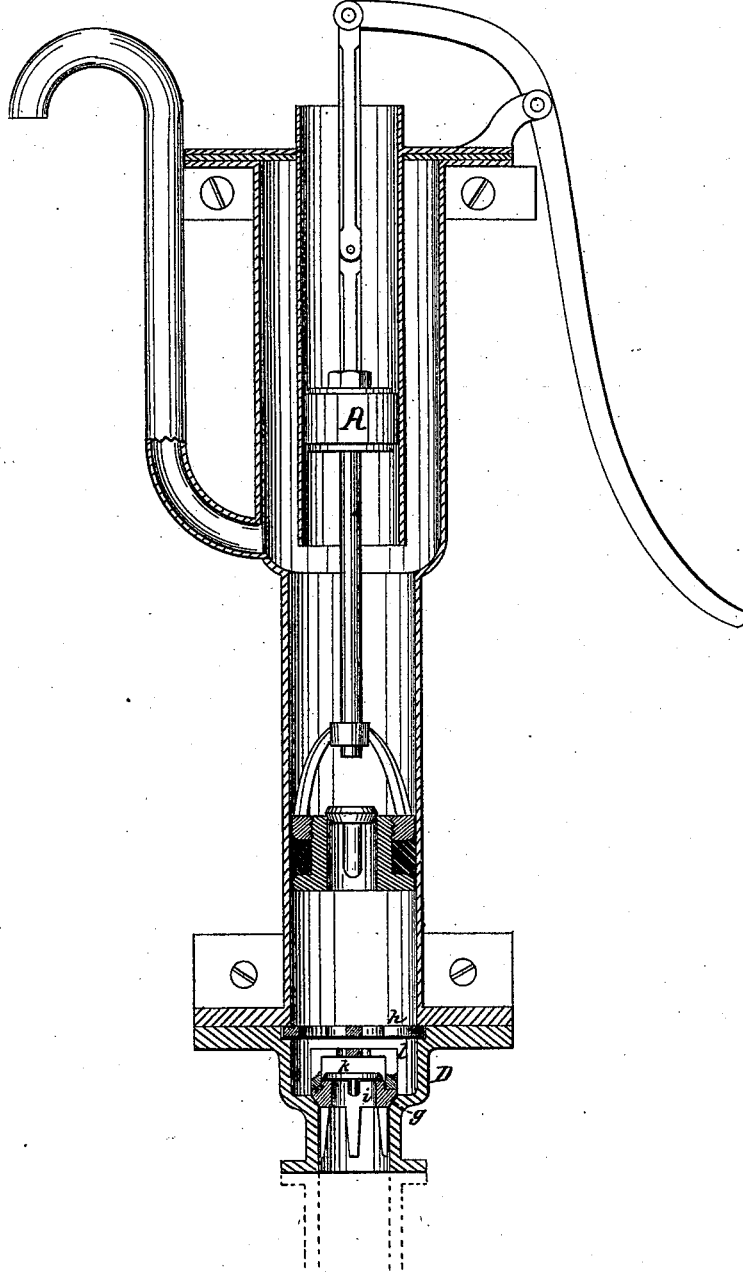

WITNESSES:

W. W. Hollingsworth
A. M. Tanner

INVENTOR:

G. W. Robaugh

BY

Ruben C. [Signature]

ATTORNEYS.

UNITED STATES PATENT OFFICE.

GEORGE W. ROBAUGH, OF OTTUMWA, IOWA.

IMPROVEMENT IN PUMPS.

Specification forming part of Letters Patent No. 194,843, dated September 4, 1877; application filed July 9, 1877.

To all whom it may concern:

Be it known that I, GEORGE W. ROBAUGH, of Ottumwa, in the county of Wapello and State of Iowa, have invented a new and useful Improvement in Pumps, of which the following is a specification:

Figure 1 is a vertical section of my improved pump-piston. Fig. 2 is a vertical section of the valve and cage. Figs. 3 and 4 are detail views of parts of the piston-follower. Fig. 5 represents a complete pump with the follower and valve in position.

Similar letters of reference indicate corresponding parts.

The object of my invention is to provide a piston for pumps of the character shown in a Patent No. 149,953, granted to me April 21, 1874, that may be readily packed without removing it from the pump; also, to provide an efficient valve and valve-seat.

In the drawings, A is the main portion of the piston-head, which is secured to the piston-rod B. The piston is provided with a flange, *a*, against which packing is pressed by the follower C. This follower is sectional, being made of two parts, *b c*. The part *b* has a downwardly-projecting rim, and is slotted from its center to its periphery to receive a projection, *d*, on the part *c*, which completes the rim and fills the slot in the said part *b*. The part *c* is also slotted, and upon the part *b* a projection, *e*, is formed, which fills the slot in the part *c*. A nut, *f*, holds these parts of the follower in place on the rod and against the packing.

When the packing is to be removed the nut is loosened, and the part *c* is removed from the rod by raising it upward and moving it sidewise until it is free from the piston-rod. The part *b* is removed in a similar manner.

The valve casing or cage consists of a casting, D, having upon each end a flange for connecting it with the other portion of the pump. This casting is of two diameters, the lower portion being the smaller, and having formed in it the valve-seat *g*. In the upper and larger portion there is a rabbet for receiving the grating or cover *h*, which is held in place by the pump-barrel.

Below the grating *h* there is an annular valve, *i*, that is fitted to the valve-seat *g*, and to a seat formed on its upper surface a valve, *k*, is fitted. Over the valve *k* there is a cage, *l*, that is secured to the annular valve *i* by screw-threads.

The lift of the annular valve is limited by the grating *h*, and the lift of the valve *k* is limited by the cage *l*. The lift is thus divided between the two valves, and greater capacity is secured than is possible with a single valve, unless the lift is unduly increased.

The general construction of the cylinders, water-discharge pipe, and main piston (shown in Fig. 5) is the same as in my previous patent, and need not be particularly described in the present instance.

Having thus described my invention, I claim as new and desire to secure by Letters Patent—

1. The piston-head consisting of the fixed portion A and the slotted removable parts *b c*, substantially as shown and described.

2. The part D, having two diameters, and containing the valve-seat *g*, the grating *h*, and the double valve, in combination, substantially as shown and described.

GEORGE WASHINGTON ROBAUGH.

Witnesses:

R. A. WILSON,
WM. H. CALDWELL.