

W. C. ALLISON.  
HYDRAULIC TESTING-MACHINES.

No. 194,857.

Patented Sept. 4, 1877.

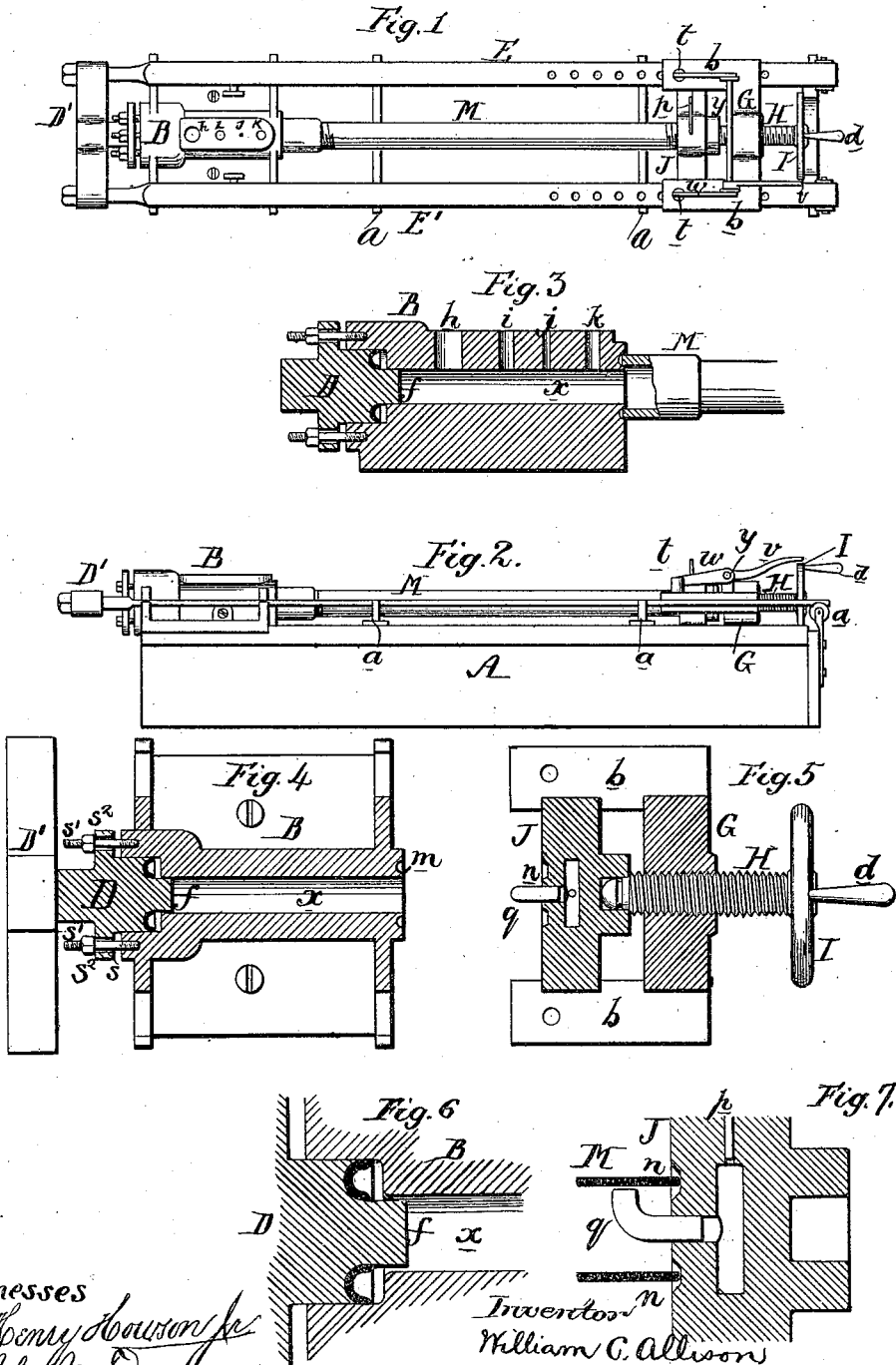

Witnesses  
*Henry Howson Jr.*  
*John M. Deemer.*

Inventor  
 William C. Allison  
 by his Attorneys  
*Howson and son*

# UNITED STATES PATENT OFFICE.

WILLIAM C. ALLISON, OF PHILADELPHIA, PENNSYLVANIA.

## IMPROVEMENT IN HYDRAULIC TESTING-MACHINES.

Specification forming part of Letters Patent No. 194,857, dated September 4, 1877; application filed August 1, 1877.

*To all whom it may concern:*

Be it known that I, WILLIAM C. ALLISON, of Philadelphia, Pennsylvania, have invented a new and useful Improvement in Hydraulic Testing-Machines, of which the following is a specification:

The object of my invention is to test pipes, and other objects, with rapidity and certainty in the manner and by the mechanism which I will now proceed to describe, reference being had to the accompanying drawings, in which—

Figure 1 is a plan view of my improved testing-machine; Fig. 2, a side view; Fig. 3, a vertical section of part of the machine drawn to an enlarged scale; Figs. 4 and 5, sectional plans of opposite ends of the machine; Fig. 6, a section drawn to a still larger scale of the ram and part of the cylinder of the machine; and Fig. 7, a vertical section of a part of the opposite end of the machine.

To one end of the base A of the machine is secured the cylinder B, of which D is the ram, adapted to the cylinder in the manner described hereinafter. This ram forms part of a cross-head, D', to which are secured the two draw-bars E and E', the latter being prevented from sagging by bearings or rollers a.

A cross-head, G, at the rear end of the machine has guides b b, adapted to the draw-bars, on which the said cross-head can be adjusted to different positions, and to which it can be secured after adjustment by pins or otherwise. Through this cross-head G passes a screw, H, provided at one end with a wheel, I, having a suitable handle, d, and so connected at the opposite end to a follower, J, that, while the screw can turn freely independently of the said follower, the longitudinal position of the latter on the cross-head is dependent upon the screw.

As shown in the drawings, the machine is arranged for subjecting pipes to internal pressure, the cylinder B being recessed at m for receiving one end of the pipe M, and the follower J being recessed at n for receiving the opposite end of the said pipe.

The detailed construction of that portion of the machine which constitutes the hydraulic press will be best understood by reference to the enlarged views, Figs. 4 and 6.

The ram D is reduced in diameter at f so

that an annular pocket may be formed for the reception of the U-shaped packing-ring, the reduced portion f of the ram projecting into the bore x of the cylinder, in which, however, it should fit so freely that the water in the cylinder can gain access to the packing, or the projection f may fit snugly in the cylinder, provided there be grooves or passages for the water.

On the ram D is formed a collar, s, through openings in which project the stems of bolts s<sup>1</sup>, the inner ends of which are secured to the head of the cylinder B, while their outer ends are provided with nuts, s<sup>2</sup>, so that by adjusting these nuts the extent of the outward movement of the ram can be readily governed, for a purpose rendered apparent hereinafter.

In the top of the cylinder there are four orifices, namely, the largest orifice, h, communicating through a suitable pipe with a supply of water under a comparatively light pressure; the orifice i, for the admission of water under a comparatively heavy pressure; the orifice j, communicating with a suitable gage for determining the pressure exerted by the machine on a pipe; and the orifice k, for water under the highest pressure which may be demanded in using the machine, all the pipes communicating with these orifices being furnished with suitable cocks. Water under pressure may be forced through either of the orifices i or k by means of the pumps usually connected with hydraulic presses, but I prefer to depend upon the water stored under pressure in what are known as "accumulators."

In the present instance the cross-head G is connected to the draw-bar by two pins, t, which pass through holes in the bars and guides b, the pins being connected to arms w on a shaft, y, to which is secured a lever, v, by depressing which the two pins may be withdrawn simultaneously from the holes in the bars prior to the adjustment of the cross-head.

The following is the mode of procedure in using the machine: The cross-head G is first adjusted on the draw-bars E and E', in a proper position to accord with the length of the pipe M to be tested, which is introduced between the recessed end m of the cylinder and the recess n in the follower J, suitable

packing being arranged at these points. The screw H is then so turned that the pipe shall be confined between the cylinder and follower, after which sufficient water is introduced through the orifice *h* into the cylinder and pipe to fill the same.

It is essential that during this flow of water into the pipe the air should be at liberty to escape freely therefrom, for which purpose there is formed in the follower J a chamber, which communicates with the interior of the pipe M through a bent tube, *g*, and with the atmosphere through a pipe, *p*, the latter being furnished with a suitable stop-cock.

The tube *g* is bent upward at the inner end, so as to closely approach the top of the pipe M, just enough space being left between the end of the tube and the interior of the pipe to permit the passage of air into the latter, the escape of the entire body of air in the pipe as the latter becomes filled with water being thus insured.

As soon as the pipe and cylinder have been filled with water and the air excluded therefrom, the air-pipe and the pipe communicating with the orifice *h* are closed, and the pipe communicating with the orifice *i*, or that communicating with the orifice *k*, is opened, so that the pipe M to be tested shall be subjected to a determinate pressure from an accumulator or pump, and this pressure will be indicated on the gage communicating with the orifice *j*.

The moment the water in the pipe M is subjected to the predetermined pressure the ram D will be moved outward to a slight extent, and this movement will be imparted, through the draw-bars E E', cross-head G, and screw H, to the follower; hence the pipe will be so firmly confined between the cylinder and follower that leakage at the ends of the pipe will be impossible.

The extent to which the ram D moves outward, and consequently the degree of longitudinal strain to which the pipe M is subjected, are governed by the position of the nuts *s*<sup>2</sup> on the bolts *s*<sup>1</sup>, so that by properly adjusting these nuts the longitudinal pressure on the pipe may be regulated as demanded by the varying strength and diameter of the pipes which are being operated upon.

After the pipe has been tested the pressure is withdrawn by closing the communication between the accumulator and the cylinder, the air-pipe *p* is opened, and the screw H is so manipulated as to withdraw the follower from the end of the pipe M, when the water will escape therefrom and the pipe may be removed to make way for another pipe to be subjected to the testing operation after the ram, draw-bars, &c., have been restored to their first positions.

It will be evident that the machine may be used for compressive tests and readily organized for determining the tensile strength of solid bars and other objects.

I claim as my invention—

1. A hydraulic testing-machine in which a stationary cylinder, B, and ram D are combined with a follower, J, connected to the said ram, all substantially as set forth.

2. The combination of the cylinder, the ram and its draw-bars, the cross-head G, and the follower J, adjustable on the cross-head, all substantially as specified.

3. A hydraulic testing-machine in which a cylinder, B, provided with one or more water-inlets, is combined with a follower provided with an air-outlet, as and for the purpose set forth.

4. The combination of the follower J, its inclosed chamber, the bent inlet-pipe *g*, and a suitable outlet.

5. The combination of the cylinder B and its ram with the orifice *h* communicating with a water-supply, the orifice *j* communicating with a gage, and the orifices *i* and *k*, one or both, communicating with a supply of water under pressure, all as described.

6. The combination of the cylinder B, its ram D having a projection, *f*, extending into the interior of the cylinder, and the packing *e*.

7. The combination of the ram D, having the cross-head G connected thereto, with the bolts *s*<sup>1</sup> and their nuts *s*<sup>2</sup>.

In testimony whereof I have signed my name to this specification in the presence of two subscribing witnesses.

WM. C. ALLISON.

Witnesses:

HERMANN MOESSNER,  
HUBERT HOWSON.