

M. HAINQUE.
 ROTARY PRINTING-PRESSES.

No. 194,902.

Patented Sept. 4, 1877.

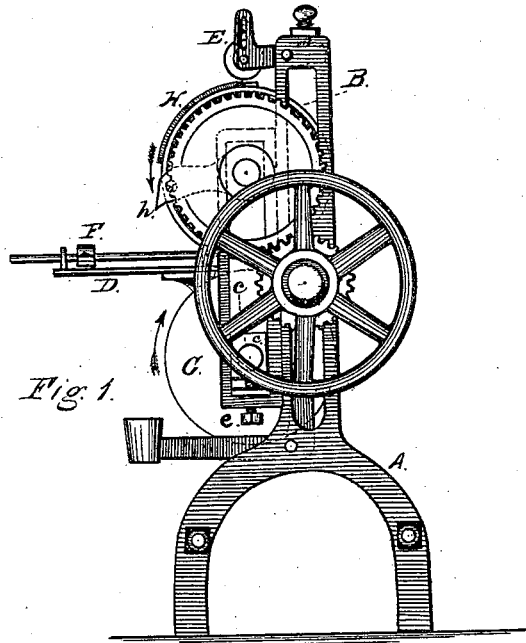

Fig. 1.

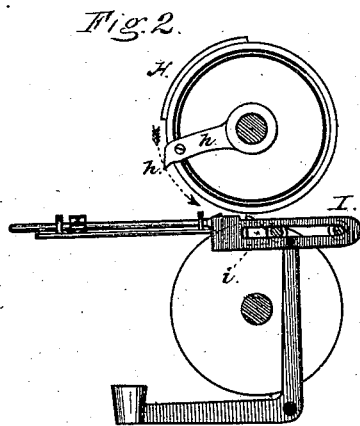

Fig. 2.

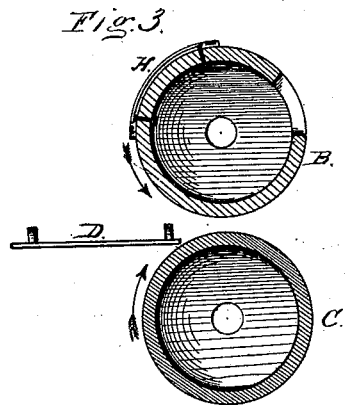

Fig. 3.

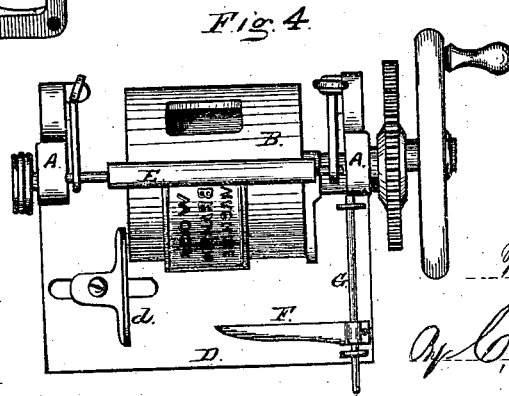

Fig. 4.

Witnesses:

E. J. Taylor
Edward Deane

Inventor:

Martial Hainque
Wm. M. Smith
his Attorney

UNITED STATES PATENT OFFICE.

MARTIAL HAINQUE, OF SAN FRANCISCO, CALIFORNIA, ASSIGNOR TO
HIMSELF AND ALLEN J. TAIT, OF SAME PLACE.

IMPROVEMENT IN ROTARY PRINTING-PRESSES.

Specification forming part of Letters Patent No. 194,902, dated September 4, 1877; application filed
May 21, 1877.

To all whom it may concern :

Be it known that I, MARTIAL HAINQUE, of the city and county of San Francisco, in the State of California, have invented a certain new and useful Machine for Printing or Marking on the Covers of Wooden Boxes, which invention is fully set forth in the following specification and accompanying drawing.

In the said drawing, Figure 1 is a side elevation of my machine. Fig. 2 is a detail view of the type and impression cylinders and the automatic feeding device. Fig. 3 is a section through the cylinders. Fig. 4 is a top view of the machine as shown in Fig. 1.

The object of my invention is to provide a machine for printing or branding the covers or other parts of wooden boxes, which shall do automatically what has heretofore been done by hand.

It consists in the construction, arrangement, and combination together of a hollow type-cylinder to hold the printing or marking types or plates, an adjustable impression-cylinder, an automatic feeding device, and an inking apparatus, which operate together to mark or brand the covers or parts of wooden boxes in a perfect and rapid manner, and more accurately than can be done by hand, as will be more fully set forth hereinafter.

In the accompanying drawings, A A represent the frame of my machine; B, the type-cylinder; C, the impression-cylinder, and D the feeding-table. E is the inking apparatus, and F the feeding-finger.

The cylinders are rotated by suitable gearing, or by belts and pulleys, so arranged that the two cylinders shall revolve at the same speed, and that the distance between them shall be adjustable and capable of being regulated to accommodate different thicknesses of boards and sizes of type or plates.

The lower cylinder C is held in adjustable bearings *c c*, set at the required height by means of the set-screws *e* in the lower part of the frame A.

The feed-table D has an adjustable gage, *d*, and a reciprocating rod, G, to which the feeding-finger F is secured. This rod is moved in one direction, or forward, to introduce the end of the board within the space between the cyl-

inders by means of the finger *h* held upon the shaft or to the side of the type-cylinder, and its movement in the opposite direction, or backward, is produced by a weight or the action of a spring.

This feeding device is illustrated in the detail view, Fig. 2, of the drawing. The rotating finger *h* on the cylinder B is adjusted with such reference to the position of the type or branding plate upon the cylinder that the rod and its finger F will be moved forward at the moment that the front edge of the type-plate H comes in line with the front edge of the feed-table. Thus the board will be caught at this point and drawn in between the cylinders.

As the feeding-finger F is adjustable upon its rod toward and away from the front edge of the feed-table D, the machine will readily receive different sizes of boards, and can be adjusted to print or mark the brand at any required distance from the edge of the board.

When the machine is used as a branding-machine, by the introduction of a proper heating medium into the type-cylinder, which is made hollow or with a chamber, the inking apparatus E is set up out of contact with the cylinder, or is removed altogether.

From the above description of the construction of my machine, it will be seen and understood that the covers and other parts of boxes placed upon the feeding-table are presented at the proper time in an automatic manner to the action of the printing or marking cylinder, and receive the impression, one after the other, in a rapid and uniform manner, after the machine has been once properly adjusted.

By changing the position of the finger *h* upon the cylinder B or its shaft, the feeding-rod G will be operated sooner or later, as may be required, for the action of the finger in striking against the pawl *i* of the slide I, Fig. 2, will occur either at the moment that the edge of the type or branding plate H comes in line with the front edge of the feeding-table, or at such time in advance of this position that the type shall strike the board at the required distance from the edge, thus leaving a suitable margin all around the brand, which will be changed only as the feeding-finger F

and the rotating finger *h* are adjusted in a different position.

Having thus fully described my invention, what I claim as new therein, and desire to secure by Letters Patent, is—

In a machine for printing or branding the covers of wooden boxes, the combination, with the type and impression cylinders B C, of the feed-table D, the slide I, having stud *i*, the rod G, and the finger *h*, adjustably secured to the type-cylinder, whereby the feed can be so ad-

justed as to print or brand the board at any desired distance from its edge, constructed and arranged substantially as described and shown.

In testimony that I claim the foregoing I have hereunto set my hand and seal this 8th day of May, 1877.

MARTIAL HAINQUE. [L. S.]

Witnesses:

C. W. M. SMITH,
PHILIP MAHLER.