

M. PRILLAMAN.
SHINGLE-SAWING MACHINE.

No. 194,929.

Patented Sept. 4, 1877.

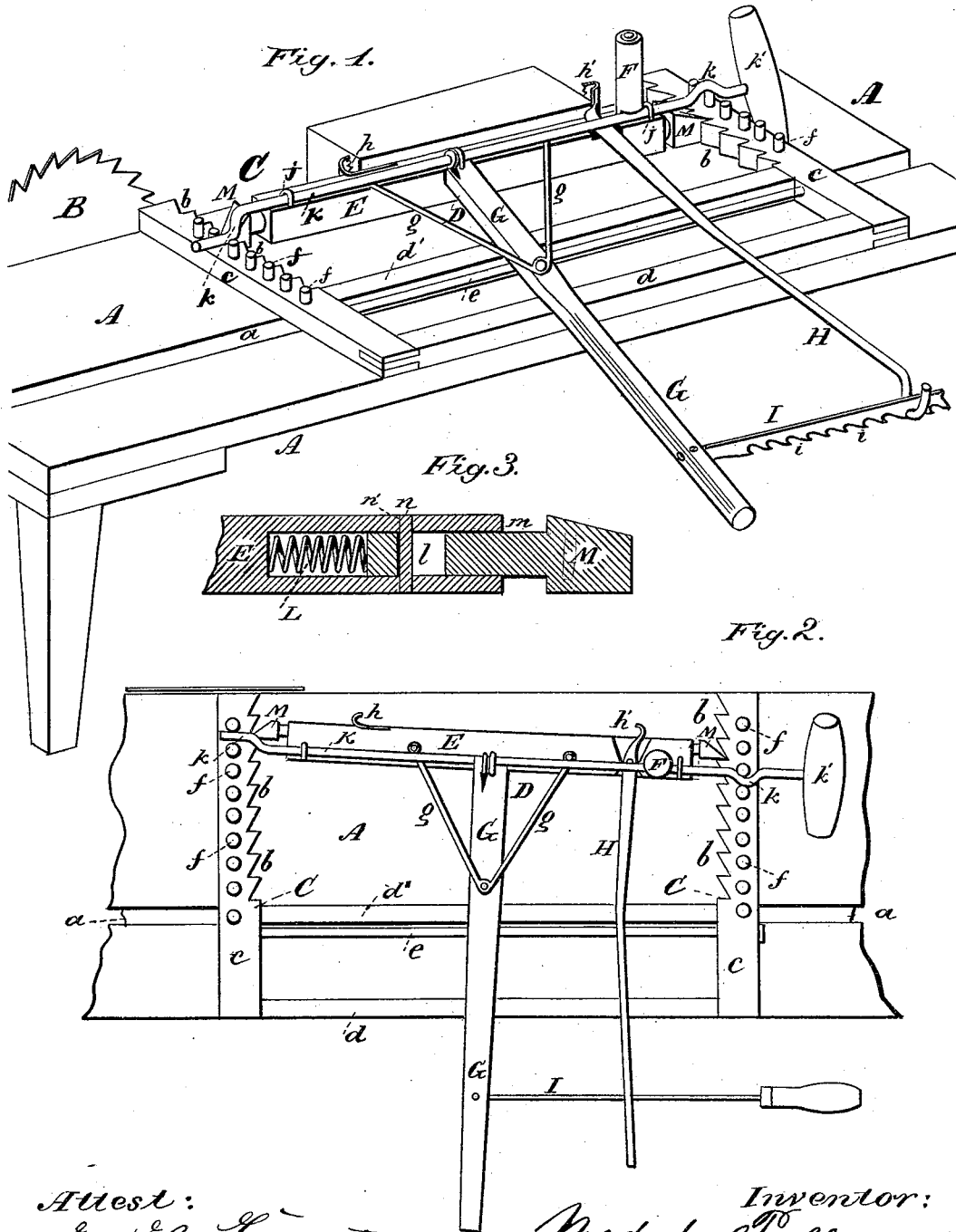

Attest:
E. O. Court,
August Petermann.

Inventor:
Medad Prillaman
by Louis Bagger & Co.
Attys.

UNITED STATES PATENT OFFICE.

MEDAD PRILLAMAN, OF CALLAWAY'S, VIRGINIA, ASSIGNOR OF ONE-HALF HIS RIGHT TO JOHN PETER SAUL, OF SAME PLACE.

IMPROVEMENT IN SHINGLE-SAWING MACHINES.

Specification forming part of Letters Patent No. 194,929, dated September 4, 1877; application filed July 20, 1877.

To all whom it may concern:

Be it known that I, MEDAD PRILLAMAN, of Callaway's, in the county of Franklin and State of Virginia, have invented certain new and useful Improvements in Shingle-Machines; and I do hereby declare that the following is a full, clear, and exact description thereof, which will enable others skilled in the art to which it appertains to make and use the same, reference being had to the accompanying drawings, which form a part of this specification, and in which—

Figure 1 is a perspective view of the machine complete and ready for operation. Fig. 2 is a plan view of the sliding and holding frames, and Fig. 3 is a sectional view of a portion of the latter frame.

Similar letters of reference indicate corresponding parts in all the figures.

This invention relates to certain improvements in machines for sawing shingles; and its object is to construct a machine which shall be cheap, effective, and easily operated by hand, as I shall now proceed more fully to describe.

In the drawings, A is the table of my improved shingle-machine. At one end thereof is the saw B (either circular or reciprocating, but shown in the drawings as a circular saw) by which the shingles are cut. C is the sliding frame or carriage. This consists of two parallel side pieces, *c c*, secured together by two cross-braces, *d d'*, arranged close by each other at one end of the frame, and a bolt, *e*, between the cross-pieces.

The inner cross-piece *d'* projects below the frame, thus forming a guide bar or rail, which slides in a slot, *a*, in the table in the operation of feeding the shingle-block to the saw.

Upon the insides of side pieces *c c* of the frame are formed ratchet-teeth *b b*, of suitable length; and on top of the side pieces, between the teeth, are formed short stout butts or projections, denoted by *f f*.

D is the frame in which the block is held while being sawed. It consists of a bar or body, E, having an upright handle, F, and a lateral shaft, G, placed at the middle thereof, and at right angles thereto. Shaft G is suitably braced by rods *g g*. Upon the front side

of bar E is secured a solid clamp, *h*, and on top of bar E is pivoted a lever, H, the end of which is shaped to form the movable clamp *h'*. At or near the end of shaft G is pivoted a lever, I, having ratchet-teeth *i* engaging with the end of clamp-lever H. Thus, when the block of wood from which the shingles are to be sawed is clamped between clamps *h h'*, the tension of lever-bar H, (which is made of spring metal,) when engaged with tooth-bar I, is sufficient to hold it in place, resting, as it does, upon the table A.

On top of the body or bar E I place a metallic rod, K, having at the end a turn-handle, *k'*. It is held in place by staples *j j*, or any other suitable devices. Upon the rod K are formed two small cranks, *k k*, turned in opposite directions, and engaging with the butts *f f* on top of side pieces *c c* of frame C. In the ends of bar E are recesses *l*. M M are triangular knobs or heads, engaging with the ratchet-teeth *b b*, and having shanks *m* fitting into said recesses *l*, where they are held in place by bolts *n* passing through slots *n'* therein, and forced outward by spiral springs L placed in the bottom of the recesses.

In operation, the frame D is first placed in frame C, in such a position that its pawls M shall engage with the innermost or lowest of the teeth *b b*. The shingle-block (which should preferably be previously finished off to the proper size and shape) is then placed on the table A, between the side pieces of frame C, and in front of the body-bar of frame E, upon which it is clamped, in the manner described. Supposing that the block now lies flush with the edge of the table, the rod K is turned one-half of a revolution by its handle *k'*. One of the cranks *k* will, by this operation, engage with the nearest butt *f*, and force the frame D forward or outward, the springs L L in the recesses *l l*, before described, having elasticity to permit this motion. A portion of the shingle-block is now exposed beyond the edge of the table, the angle at which the frame D is at the time placed giving to the exposed portion the wedge shape of a shingle, of which either the point or the butt faces the saw. The frames C and D are now slid together over the table and against the saw, which

cuts off the first shingle. The rod K is now again turned, (after returning the frames,) thus feeding the block forward, after which the cutting operation is repeated, the shingles being cut from the point and butt alternately. When the end of frame C is reached the stump is released, frame D is returned, (by lifting it out and replacing it,) and a new block is placed on the table and secured in the clamps. The relative distances of clamps *h h'* from the side pieces of frame C should, of course, be so graded that the point and butt ends of the shingles will have the proper thickness.

From the foregoing description the operation and advantages of my invention will be readily understood. Its construction, being exceedingly simple, renders it almost impossible for it to get out of order. It is cheap, operated so easily as to require the services of a boy only, and it may, finally, be worked with great rapidity.

Having thus described my invention, I claim and desire to secure by Letters Patent of the United States—

1. The sliding frame C, having side pieces *c c*, provided with ratchet-teeth *b b* and studs or butts *f f*, substantially as and for the purpose herein shown and specified.

2. The frame D, consisting of body-bar E

and shaft G, the former having solid clamp *h* and lever-clamp H *h'*, and the latter having toothed lever I, engaging with lever H, substantially as and for the purpose set forth.

3. The frame D, having body-bar E, provided with spring-pawls M M at the ends thereof, in combination with the frame C herein described, substantially as and for the purpose shown and specified.

4. The combination of the frames C D, the former having studs or butts *f f*, and the latter having turning-rod K, provided with cranks *k k*, substantially as described, for the purpose set forth.

5. The improved shingle-machine herein described, consisting, essentially, of the slotted table A, sliding frame C, having ratchet-teeth *b b* and studs or butts *f f*, and feed-frame D, having clamps *h H h'*, spring-pawls M M, and turning-rod K, having cranks *k k*, all combined, arranged, and operating substantially in the manner and for the purpose set forth.

In testimony that I claim the foregoing as my own I have hereto affixed my signature in presence of two witnesses.

MEDAD PRILLAMAN.

Witnesses:

HENRY M. DARNALL,

THOS. J. MOORE.