

J. P. VERREE. 2 Sheets—Sheet 1.  
BALE-TIES.

No. 194,939.

Patented Sept. 4, 1877.

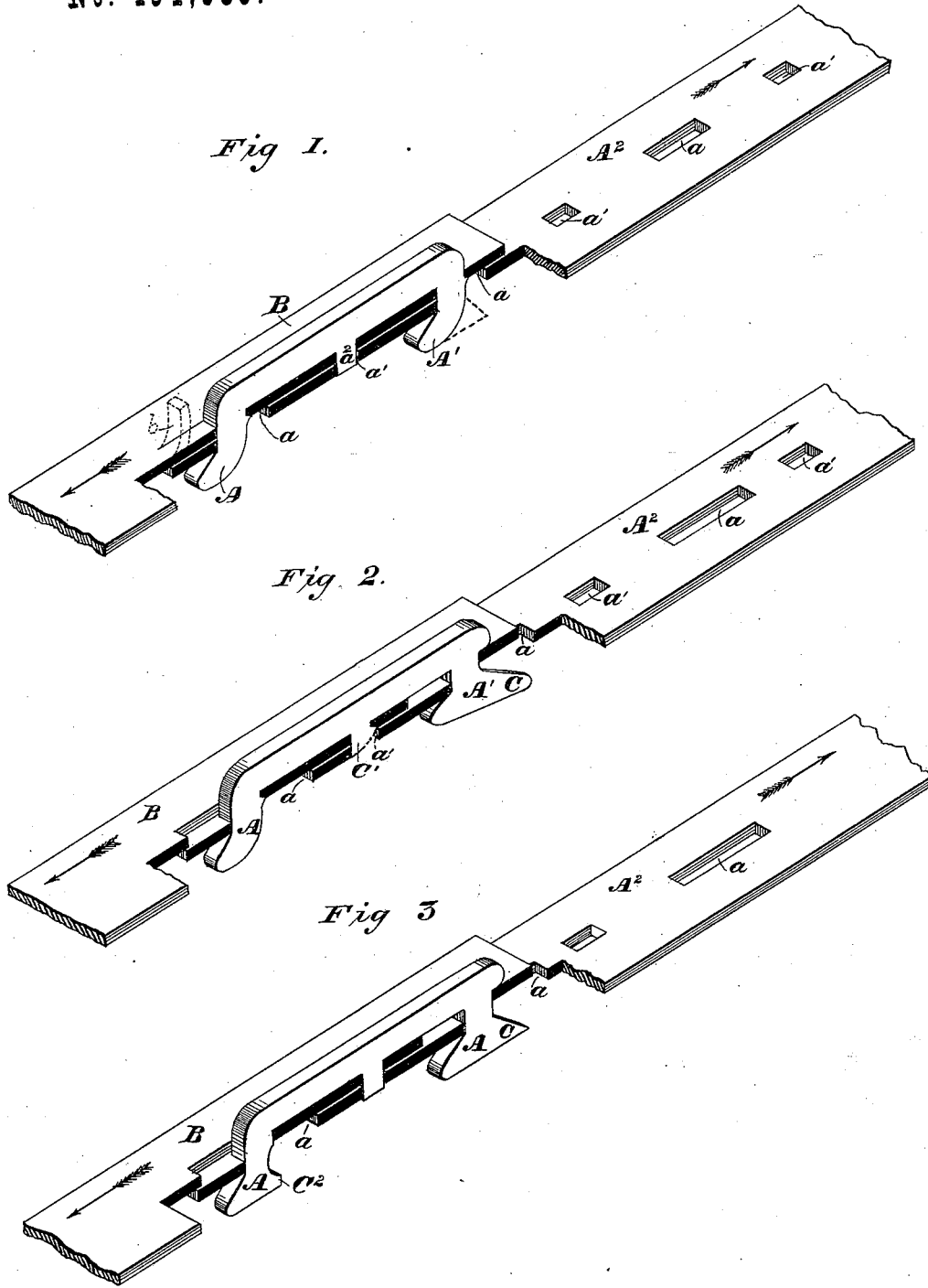

WITNESSES

*Wm. A. Skinkle.*  
*Geo. H. Brock.*

INVENTOR.

*John P. Verree*

By his Attorneys

*Baldwin, Hopkins & Peyton.*

J. P. VERREE.  
BALE-TIES.

No. 194,939.

Patented Sept. 4, 1877.

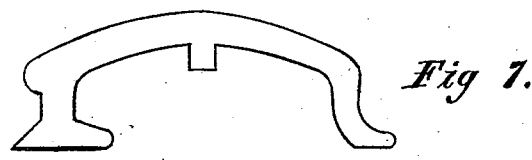
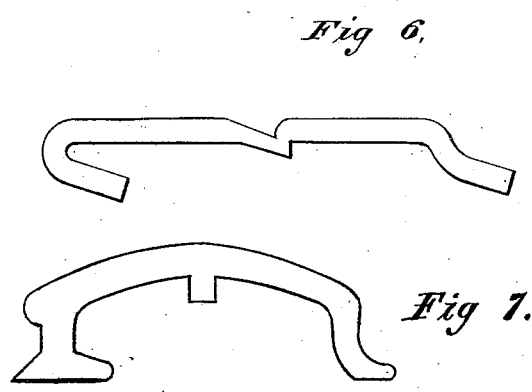
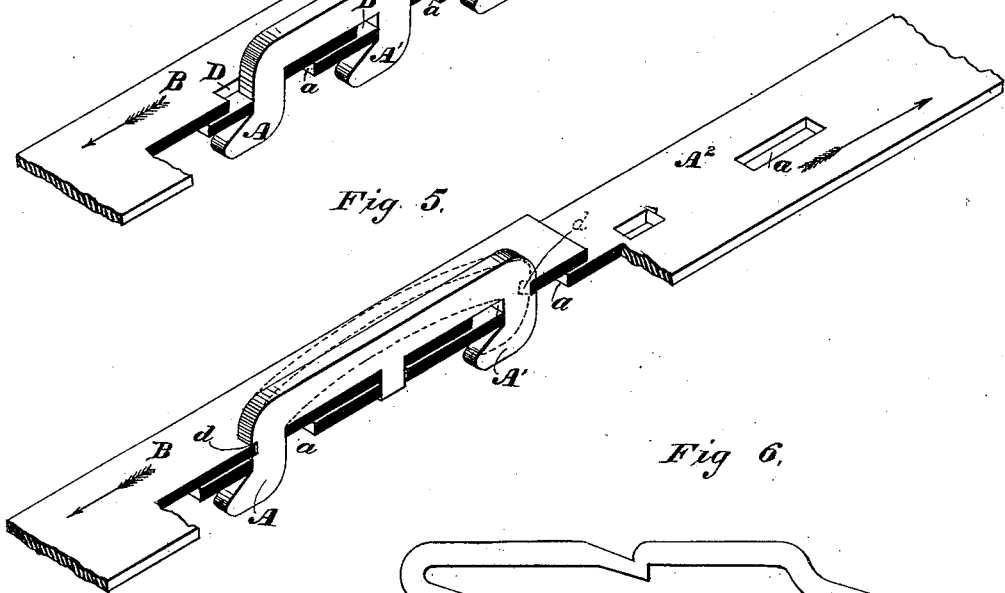
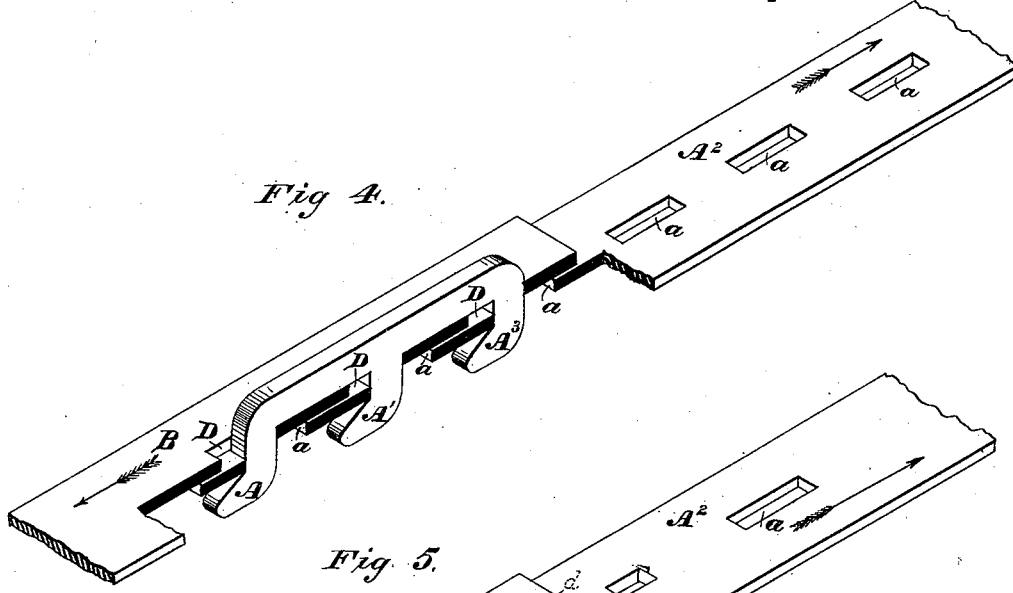

WITNESSES

*Wm A Skinkle,*  
*Geo W Brock*

INVENTOR

*John P. Verree.*

By his Attorneys

*Baldwin, Hopkins & Heyton.*

# UNITED STATES PATENT OFFICE.

JOHN P. VERREE, OF PHILADELPHIA, PENNSYLVANIA.

## IMPROVEMENT IN BALE-TIES.

Specification forming part of Letters Patent No. 194,939, dated September 4, 1877; application filed July 27, 1877.

*To all whom it may concern:*

Be it known that I, JOHN P. VERREE, of the city and county of Philadelphia, in the State of Pennsylvania, have invented certain new and useful Improvements in Bale-Ties or Band-Fastenings, of which the following is a specification:

My invention relates to band-securing devices of the class in which hooks secured to one end of a band engage with slots in the other end, one form of which class of ties or fastenings is shown by Letters Patent of the United States No. 192,312, granted me June 19, 1877.

The objects of my present invention are to strengthen such fastenings, to simplify and cheapen their construction and application to the bands, and to provide against the accidental disconnection of the ends of the bands secured together.

To these ends my improvements consist in certain peculiarities in the construction of the fastenings, in the mode of securing the fastenings to the bands, and in certain novel combinations of parts, which will hereinafter specifically be designated.

In the accompanying drawings, which show the best way now known to me of carrying out my invention and modifications thereof, in each of which there are involved principles of construction and operation common to all, Figure 1 is a perspective view of a portion of a band with its ends connected by my improved fastening, and partly broken away to show the connection more clearly; Fig. 2, a similar view, showing a modification in the form of one of the hooks, and in the central lug or teat, or third point of connection between the band ends. Fig. 3 is a similar view, showing heel-projections on the hooks or lips, projecting in directions opposite to the directions in which the respective hooks point. Fig. 4 is a similar view, showing three corresponding hooks. Fig. 5 is a similar view, showing two hooks. Fig. 6 is a side elevation of a wire or rod fastening, with a central teat or additional fastening-point; and Fig. 7 is a similar view of a fastener punched from a plate in a curved or arched form, to adapt it to be secured in the band-holes simply by straightening it.

The band or strap has a series of perforations or openings at one end, and at the other end has firmly and strongly secured to it a fastening consisting of hooks projecting in the same direction, as shown and described in my before-mentioned Letters Patent.

Instead of forming the hooks of rods or wires, as in said patent, I make them by stamping or punching by suitable means from metal plates, preferably plate or sheet iron or steel.

In this manner a strong, cheap, and easily-made fastening is provided, and such as may be completely formed, readily be firmly secured to one end of the band in various ways, some of which methods of securing the fastenings will hereinafter be described.

In some cases the fastenings may be made of rods, and provided with central bearings or intermediate band-engaging teats, presently to be described, and the complete fastening, so made, secured in one end of a band; but I prefer the plate-metal fastenings made of steel, as they are stronger, more readily made and applied to the bands, and, on the whole, more economical.

In Fig. 1 a fastening stamped or punched from plate metal has correspondingly-projecting hooks  $A A^1$ , and a central square side or straight lug or teat,  $a^2$ , serving as an additional means of connecting the band ends. The fastener may be secured to the end B of the band, after passing its hooks and teat through holes therein, by riveting or upsetting, by compressing or spreading the metal of the band, and thus causing it firmly to clamp the hooks and teat or their shanks, or by slitting the band and turning out a lip or strip,  $b$ , to allow the hooks to be entered, and then forcing back this strip. (See dotted lines.) The openings or slots  $a$  and  $a^1$  in the free end  $A^2$  of the band engage respectively with the hooks  $A A^1$  and teat  $a^2$ . The slots are sufficient in number to accommodate the band to bales of different sizes, as is well understood.

From the above description it will be obvious that when the band ends are engaged their accidental disconnection by slackening the strain on the band is prevented, as the stud  $a^2$  prevents the endwise movement or sliding of the ends upon each other—an important result of this construction. The

tendency of the hooks to back out or jump or bounce out of the slots, owing to the rough usage to which the bales are subjected, is thus wholly counteracted, and yet the ends can be disconnected by the insertion of a wedge or lever between the band ends to free the slot  $a^1$  from the teat. This teat, it will be seen, bears part of the strain when the band is under tension, and any possibility of fracturing or slitting the band is avoided.

In Fig. 2 the accidental disconnection of the slots from the hooks is prevented by a heel-extension or rear lip, C, formed on the hook  $A^1$ ; and the fastening shown by Fig. 1 may have a similar lip, as shown by dotted lines, for additional security. The central engaging point  $C^1$  in this figure is riveted to the band and inclined on its edge or outer surface to its base on one side or end, instead of being square, like the lug  $a^2$  of Fig. 1. In connecting the ends of the band the slot  $a^1$  slides over the lug  $C^1$  and comes in place. Strain on the band is partly borne by this lug, its straight side or end engaging the slot, as in Fig. 1, thus making three points of contact. Should the fastening back or slide, the hook-heel  $C^1$ , will cross the slot  $a$ , and prevent disengagement.

In Fig. 3, as an additional security against accidental disconnection, both hooks are formed with lips  $C^2$ . In this instance the stamped-out plate-metal fastening is secured to the band end by upsetting the metal of the band toward or against the sides of the hook-shanks, and the fastening thus firmly fixed in one end of the band.

In Fig. 4 three hooks,  $A A^1 A^2$ , formed from plate metal, as before described, all project in the same direction, the central hook serving, as do the teats  $a^2 C^1$ , as an additional engaging-point. They are secured in place by upsetting or displacing the metal of the band around and against their shanks, the sides of which are thus clamped, as above explained, and one or more of these hooks may have the rear lip or heel-extension. By thus securing the fastening to the band I am enabled to completely form the fastener with any desired number of hooks in an expeditious and inexpensive manner, and readily secure it to the band, the openings D in which should be made of a size to admit the hooks, ready formed, easily. The hooks may be secured by riveting as well as by upsetting, for additional security; but I prefer to adopt but one form of fixing them in place, as I have demonstrated by experiment that either way will hold the fastening securely.

In Fig. 5 the fastener is secured in place by grooving or nicking the shanks of the hooks or ends of the fastening, as at  $d d$ . When in the bent form, (shown by dotted lines,) one of the hooks is first inserted through its hole in the band, and the body portion of the fastening then straightened, and the other hook

brought in place. The notches then engage the band at the edges or ends of the openings, as shown. The metal of the fastening about the notches, or the metal of the band at and near the notches, or both, may then be upset or displaced to rivet the parts together; but this is not essential. A single notch in the fastener will serve to secure it to the band in the manner above described, and when but one notch is used it is preferable, though not absolutely necessary for security, to rivet or upset.

As shown in Fig. 7, the fastening may be punched from a metal plate in a curved, arched, or bent form, and have both the heel-projection or lip and central lug. This fastening is secured to the band end simply by straightening out the fastening between the hooks after inserting the hooks and teat through the band-holes.

In Fig. 6 I have shown a rod or wire fastening, with hooks such as in my before-referred-to Letters Patent, with the addition of the central teat, formed by punching or stamping. It is obvious that one of the hooks of such fastenings, or of the plate-metal fastenings, may be made double, as shown in said patent.

I do not herein claim, broadly, a fastening having hooks projecting in the same direction; neither do I broadly claim a fastening having a heel projection or lip at the rear of an engaging arm or hook, as such fastenings have before been made.

I claim as of my own invention—

1. The hereinbefore-described fastening, consisting of the hooks and the central teat or engaging-point, adapted to be secured to the band end and operate as specified.

2. The combination, substantially as hereinbefore set forth, of the band, the fastening, having end hooks projecting in a corresponding direction, and an intermediate teat or engaging-point, and the free end of the band slotted to engage with the hooks and teat, as set forth.

3. The combination, with the band, of the fastening, rigidly secured thereto, having a central teat or engaging-point and end hooks, one or both of which have the rear lip or lips, substantially as and for the purpose specified.

4. The hereinbefore-described bale-tie or fastening, consisting of the combination, with the band, of the hooked fastener, first formed in an arched or bent shape, and then secured to the band by inserting its hooks through holes therein and straightening out the fastener, substantially as specified.

In testimony whereof I have hereunto subscribed my name.

JOHN P. VERREE.

Witnesses:

JOHN M. LAUGHLIN,  
J. PAUL DIVER.