

E. M. BRADLEY.
HARNESS-BUCKLES.

No. 194,984.

Patented Sept. 11, 1877.

fig 1

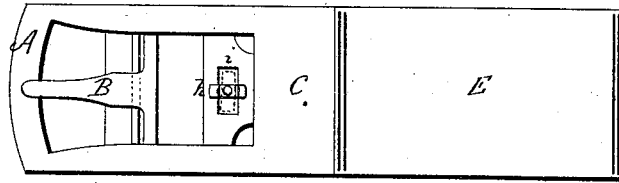

fig 2

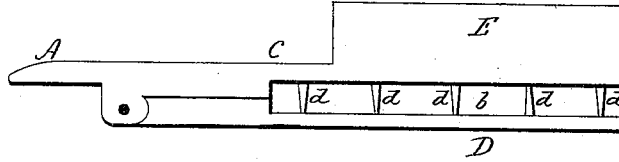
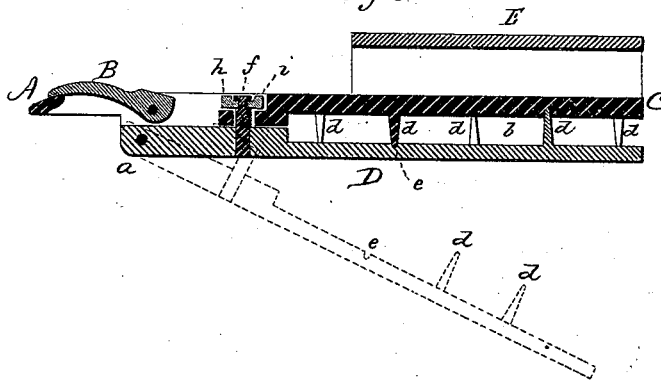

fig 3



Witnesses
J. H. Chumway
Clara Broughton.

Edwin M. Bradley
By Atty. Inventor.
J. M. Earl

UNITED STATES PATENT OFFICE.

EDWIN M. BRADLEY, OF CHESHIRE, CONNECTICUT.

IMPROVEMENT IN HARNESS-BUCKLES.

Specification forming part of Letters Patent No. 194,984, dated September 11, 1877; application filed June 12, 1877.

To all whom it may concern:

Be it known that I, EDWIN M. BRADLEY, of Cheshire, in the county of New Haven and State of Connecticut, have invented a new Improvement in Harness-Buckles; and I do hereby declare the following, when taken in connection with the accompanying drawings and the letters of reference marked thereon, to be a full, clear, and exact description of the same, and which said drawings constitute part of this specification, and represent, in—

Figure 1, a top view; Fig. 2, a side view; and in Fig. 3, a longitudinal central section.

This invention relates to an improvement in harness-buckles, with special reference to that class known as "tug or trace buckles;" the object of the invention being a simple and easy method of attaching the buckle to the tug.

It consists of a buckle-frame extending forward to form one plate, combined with a second plate hinged to the buckle-frame, and parallel with the first, the said plates provided with prongs to pass through the tug which lies between them, combined with a device for holding the two plates together, and so as to allow them to be easily separated for the introduction or removal of the tug.

A is the trace-buckle frame; B, the tongue hinged therein, in substantially the usual manner. The frame extends forward to form a plate, C. Beneath or inside this plate C is a second plate, D, hinged to the first or frame, as at *a*, and so that when closed together a space, *b*, will be left between the two corresponding to the thickness of the tug. These plates are provided with several prongs or spurs, *d*, (more or less in number,) projecting from the plates toward each other, and preferably with a cavity, *e*, in the opposite plate, so that the points of the prongs on one will enter a corresponding cavity in the other.

To attach the buckle to the tug, the plates are opened or turned from each other, as indicated in broken lines, Fig. 3, the trace introduced between the two, and then the plates brought together, so that the prongs will pass through the tug, the prongs thereby forming the attachment of the buckle to the tug.

To secure the plates together, and yet allow them to be easily opened, a stud, *f*, is formed on one part, with a turn-button, *h*, on its end. In the other part there is a corresponding slot, *i*, through which the button will pass when turned parallel with the slot, as seen in broken lines, Fig. 1, and when the plates are closed the button *h* is turned across the slot *i*, so as to bear upon the upper surface, and as seen in Figs. 1 and 2. In this condition the plates are securely held together, and to remove or attach the tug it is only necessary to re-turn the button; hence the buckle possesses in itself all the means necessary for attachment to the tug.

Preferably on the outer plate C a pocket, E, is formed for tucking the end of the trace. The trace end therefore covers the button *h*, and prevents its accidental displacement.

I do not broadly claim providing one part with pins as a means for securing the buckle to the tug, as such, I am aware, is not new.

I claim—

In combination with the buckle-frame A and the plate C, as a part thereof, the plate D hinged to the frame, the inner or corresponding surfaces of the two plates provided with prongs *d*, and with means, substantially such as described, for securing the plates together upon the tug, all substantially as specified.

EDWIN M. BRADLEY.

Witnesses:

J. H. SHUMWAY,
CLARA BROUGHTON.