

T. OWENS.
VENTILATORS.

No. 195,039.

Patented Sept. 11, 1877.

Fig-1.

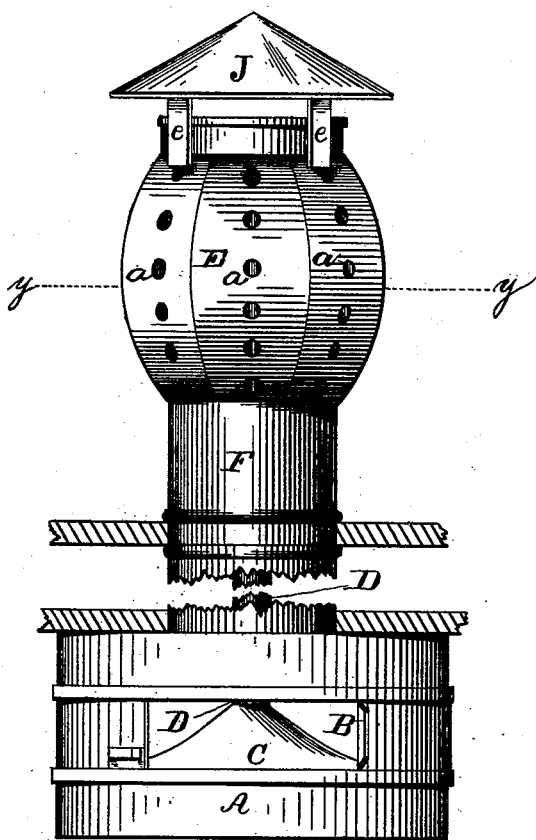

Fig-2.

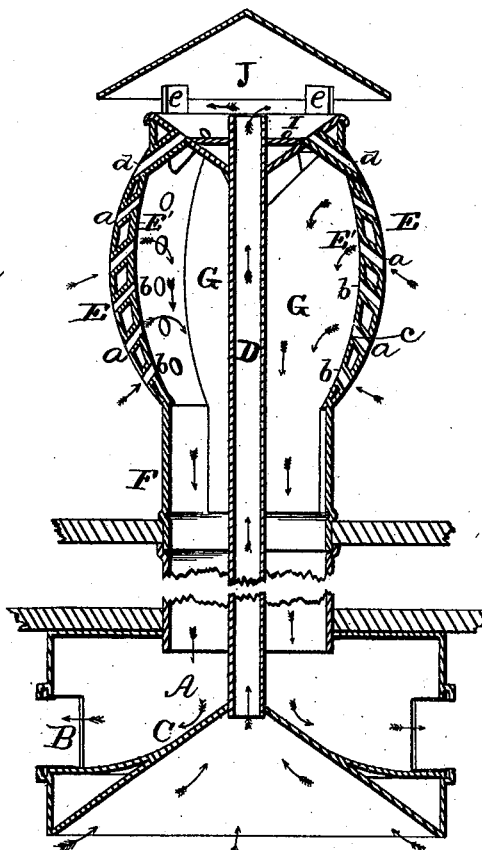

Fig-3.

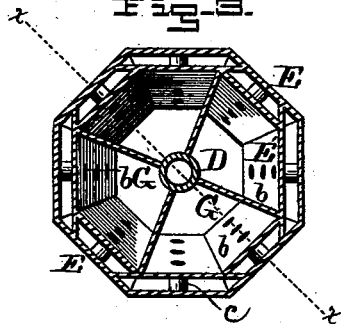
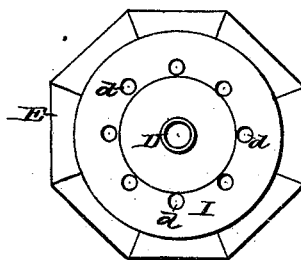

Fig-4.



WITNESSES:

Jas. F. DuRoiel
Albin N. Long.

INVENTOR:

Thomas Owens M.D.
M. S. Navy.

PER

A. J. Abbott.
ATTORNEY.

UNITED STATES PATENT OFFICE.

THOMAS OWENS, OF UNITED STATES NAVY.

IMPROVEMENT IN VENTILATORS.

Specification forming part of Letters Patent No. 195,039, dated September 11, 1877; application filed August 28, 1877.

To all whom it may concern :

Be it known that I, THOMAS OWENS, M. D., United States Navy, of Washington, in the county of Washington and District of Columbia, have invented certain new and useful Improvements in Ventilators; and I do hereby declare that the following is a full, clear, and exact description thereof.

This invention relates to certain improvements in ventilating ships, cars, and buildings; and the invention consists in a ventilator constructed and arranged as will be hereinafter more fully set forth.

In order to enable others skilled in the art to which my invention appertains to make, construct, and use the same, I will now proceed to describe its construction and operation, reference being had to the accompanying drawing, which forms a part of this specification, and in which—

Figure 1 is a side view. Fig. 2 is a vertical section, taken upon the line *xx* of Fig. 3. Fig. 3 is a cross-section, taken upon the line *yy* of Fig. 1; and Fig. 4 is a plan view of the top I.

A represents a deflecting-chamber, constructed of any suitable material and of any desired shape, having arranged on the vertical sides two or more slides or doors, B. This chamber is provided with a deflector, C, placed in the bottom of the chamber and extending with an easy curve from the central escape-pipe D to the outward extremity of the chamber.

The escape-pipe D extends upward from the center of the deflector C through the center of the neck F and head E, and through the top piece J, to which it is permanently attached, to a point flush with the top of it, and serves as a means of exit for all gases collected by the cone-shaped bottom of the deflector C.

The head E is made in any desired form, (that shown in Fig. 1 of drawing being preferred,) and provided with an inner skin, E', as shown in Figs. 2 and 3, and communicates with the deflecting-chamber by means of the neck F, which may be of any required length.

Series of openings *a* are made in the head E, and a corresponding series of openings, *b*, are made in the skin E', the bottoms of which

are either on or above a line with the tops of the openings *a*. These openings *a* and *b* are connected by tubes *c*, which have an upward inclination from *a* to *b*, as shown, for the purpose of excluding rain and snow.

Between every alternate series of openings is placed a radial partition, G, which is attached to the skin E', the top piece J, and the pipe D, so as to make a tight chamber, with the exception of the points of entrance through the pipes *c* and the exit at the bottom of the partition when the chamber is left open. By this arrangement all the air entering by way of the pipes *c* is conveyed down through the neck F to the deflecting-chamber.

A number of tubes, *d*, are placed in the upper part of the head E, leading through the skin E' to and through the bottom of the top I at a point adjacent to the escape-pipe D, as shown in Figs 2 and 4. These tubes have a twofold function, to wit: They act as draft-tubes, conveying a draft of air to the side of the escape-pipe, and they drain the water from the top.

Over the top is placed a cap, J, which is supported by arms *e*, which extend down, and are connected to the sides of the head in any suitable manner.

The operation of my device is as follows: The deflecting-chamber A is attached to the ceiling of the compartment to be ventilated, (preferably in the center of the compartment,) the neck extending through the intervening space to the open air, where the head E is placed, so as to freely catch the wind when blowing from any quarter. Air enters the head E through the openings *a* and tubes *c*, then passes down, as shown by arrows in drawings, the neck F, until it enters the deflecting-chamber and strikes the deflector C, by which it is thrown off in a line immediately beneath and parallel to the ceiling. From this locality (being fresh and cool) it descends, forcing the gases to the center and out through the escape-pipe D. By this means a continuous current of air is made to pass through a compartment without the body of the occupant being exposed to a draft.

Although it is obvious that this device may be used wherever compartments are to be ventilated, yet it is especially intended for use on

ships, in all kinds of weather, to replace the canvas ventilator now in use, which can be utilized only in fair weather.

Having thus described my invention, what I claim as new, and desire to secure by Letters Patent, is—

1. A deflecting-chamber, substantially as shown and described, constructed, arranged, and operating to throw the fresh air out into the compartment in a line with the ceiling thereof.

2. The hereinbefore-described ventilator, having a deflecting-chamber, A, provided with slides B and deflector C, substantially as and for the purpose set forth.

3. The combination of the head E, skin E', and pipes c, all arranged substantially as shown, for the purpose specified.

4. In a ventilator, the combination of the deflecting-chamber A, having slides B, deflector C, head E, skin E', and tubes c, substantially as described.

In testimony that I claim the foregoing as my own I affix my signature in presence of two witnesses.

THOMAS OWENS, M. D.

Witnesses:

JAS. F. DUHAMEL,
ALBIN M. LONG.