

H. U. PALMER.
BARREL-TRUSSING MACHINES.

No. 195,041.

Patented Sept. 11, 1877.

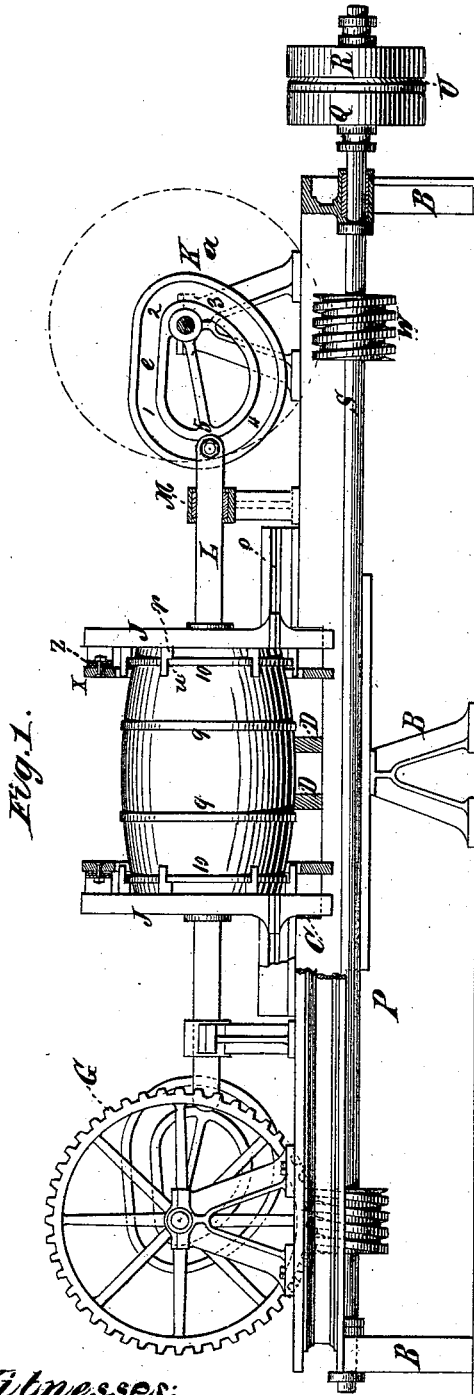

Fig. 1.

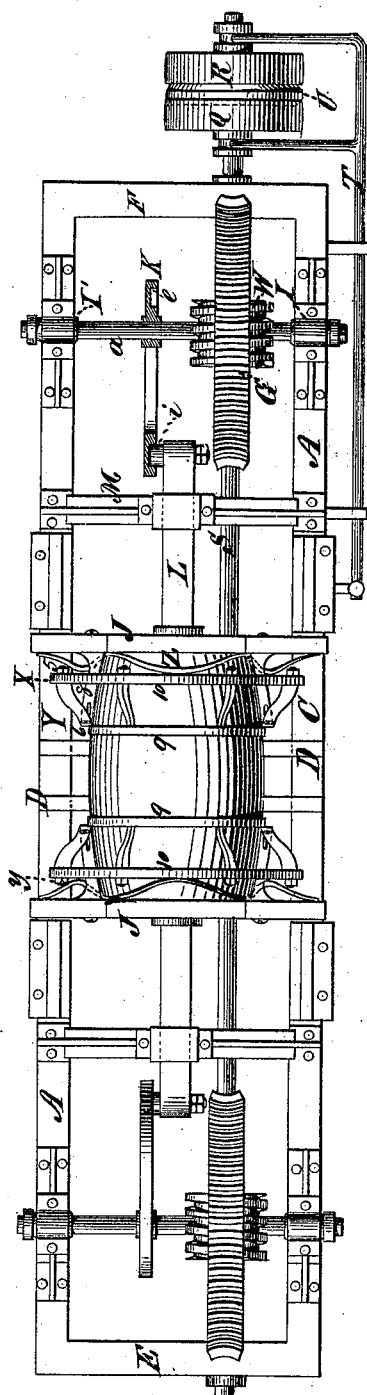

Fig. 2.

Witnesses:
H. P. Ryan
W. R. Lorenz

Henry U. Palmer Inventor
by *Minson & Phillips*,
Attorneys

H. U. PALMER.
BARREL-TRUSSING MACHINES.

No. 195,041.

Patented Sept. 11, 1877.

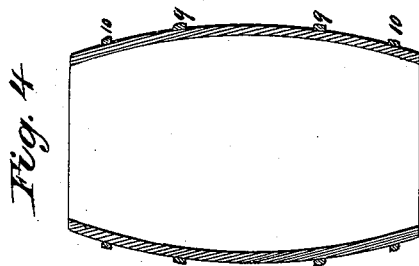
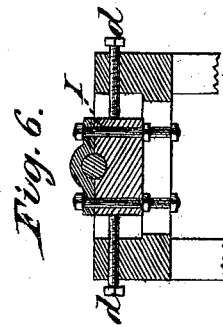
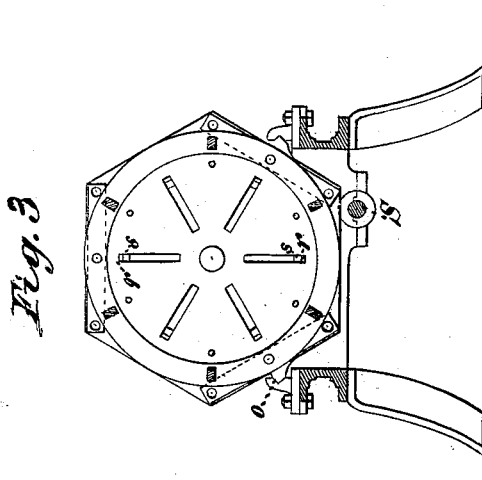
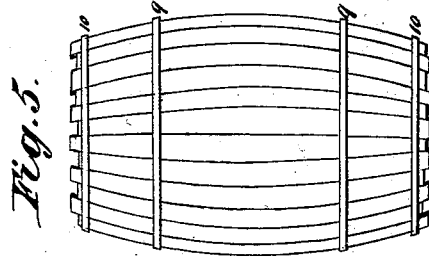

Witnesses
W. A. Looney
W. A. Looney

Inventor
Henry U. Palmer,
by Mansou & Philipp
attorneys

UNITED STATES PATENT OFFICE.

HENRY U. PALMER, OF BROOKLYN, NEW YORK.

IMPROVEMENT IN BARREL-TRUSSING MACHINES.

Specification forming part of Letters Patent No. 195,041, dated September 11, 1877; application filed November 20, 1875.

To all whom it may concern:

Be it known that I, HENRY U. PALMER, of the city of Brooklyn, State of New York, have invented an Improvement in Machines for Trussing Barrels, of which the following is a specification:

My improved machine is illustrated in the accompanying drawing, in which—

Figure 1 is a side elevation, partly in section; Fig. 2, a plan view; Fig. 3, a transverse section, exposing the face of one of the trussing-heads; Fig. 4, a sectional view of a barrel-body as treated by this machine; Fig. 5, a view of a barrel-body set up by hand in the condition in which it is placed into the machine; and Fig. 6, a view of the sliding bearing.

Like letters of reference indicate like parts.

In the production of wooden barrels the staves composing their bodies are set up in cylindrical form and temporarily supported by iron hoops, as in Fig. 5. In this primary stage the staves project beyond the hoops at either end, and are but loosely held in their embrace, and consequently are not drawn closely together, having open joints and little strength. To draw the staves together, and thus tightly compress their seams or joints, and at the same time even or plumb their ends, is the object of my invention; which consists in an apparatus and method of operation too fully hereinafter set forth to need preliminary description.

The several parts of the mechanism are supported by a rectangular base-frame, consisting of side rails A and end rails E and F, which rest upon legs or stanchions B. The frame thus composed is depressed near its longitudinal center, as at C, where transverse bars or skids D connect its side rails A. At each end of the said base-frame mechanisms having the same construction and mode of operation are mounted, which mechanisms actuate the reciprocating heads J, as will be fully hereinafter set forth. The said mechanisms consist of a worm-wheel, G, fast upon a shaft, a, which is mounted at its ends in sliding boxes I I', (see Fig. 6,) the position of which with relation to the supporting-brackets H is determined by the adjusting-screws d.

The shaft a also carries fast upon it a cam,

K, in the groove e of which runs a friction-roll or pin, i, situated at the end of a piston-rod, L. This piston-rod L is made square or of any other sectional form which will secure precision of its movements, and slides in a correspondingly-shaped bearing provided in the bridge-bracket M. The head J is fast upon the end of this piston-rod, and is centered and guided by n, which runs in grooves o in the bearing-blocks N, which are cast with or are fastened upon the side rails A. (See Fig. 3.) The head J is shown as octagonal, but it is obvious that it may be of any other shape, and provided with other means for properly securing it in true position during its reciprocations, which are imparted to it by the following means: A shaft, S, extends longitudinally through the machine, and runs in journal-bearings O fixed upon the end rails E F. It carries at one end a friction-clutch, which is shown as formed by two loose pulleys, Q R, which may be belted to run in opposite directions, either of which may be carried by means of the sliding rod T into contact with the angular-rimmed disk U, which is fast upon the shaft S. Said shaft S may thus be revolved in either direction at the will of the attendant. Any other construction of friction-clutch may be adopted. A worm, W, is fast upon the shaft S, and engages with and rotates the worm-wheel G, which in turn revolves the cam K, through which is imparted a reciprocating motion to the head J. The groove e in the cam K is of such a curve that it will impart a slow and powerful movement to the head J, gradually decreasing in speed as the extreme end of the forward stroke of the piston-rod L is approached—that is, while the friction-roll is passing from the point 4 to that 5 of the groove e; and the reverse of this movement as the head is caused to recede—that is, while the friction-roll is passing from the point 5 to that 1. Also, that the movements of said head will be rapid while the friction-roll is passing from the point 3 to that 4, or from the point 1 to that 2 of the groove e, in being thrust forward or carried backward in its reciprocations. And, further, that while the friction-roll is passing from the point 2 to that 3, which is at the end of its rearward

stroke, the head will be nearly at rest, thus giving ample time for the removal and introduction of a barrel-body between the heads J.

The head J is thus rapidly brought toward and rapidly carried away from the center of the machine, and at the extreme forward end of its stroke moves slowly forward and back. This head J is provided with arms *r*, Figs. 1 and 3, (omitted in Fig. 2,) projecting toward the center of the machine, which are held rigidly in sliding heads *s*, which are adjustable in radial slots in the head J at any point in which they may be secured by screws or any other approved means for fastening them. These arms *r* are cut away on their inner faces to form seats or shoulders *u*. The head J also carries a ring, X, hung to it by springs Z, which, in this instance, are leaf-springs, but may be of any other construction which will afford to the ring X an elastic seat. Curved arms Y, which, like the arms *r*, may have shoulders provided on their inner faces, are fastened to the ring X by bolts extending through it and secured by nuts 5; but any other mode of securing them may be adopted, and they may be made to adjust in radial slots. Their front ends have pins 6 projecting right angularly from elongated slots in them, which also play freely in similar slots 7 in guide-bars 8, which project from the head J. Thus constructed, the arms Y may slightly reciprocate or play longitudinally independently of the movements of the ring X, whose motion, independently of the head J, is accomplished through the elasticity of the springs Z, which support the said ring J, to which they are hung, which ring is centered by the guide-bars 8, upon which its inner periphery rests. They may also have a slight vertical movement by reason of the transverse slots in their ends, which adapts them to operate upon different sizes of barrels. The arms Y, whether provided with guide-bars 8 or not, may each be supported upon springs to furnish their elastic seat.

While the above description extends to the devices at one end of the machine, it is to be observed that those at the other end are duplications of them, being alike in construction and mode of operation, as before stated.

The operation is as follows: The arms *r* are adjusted radially to suit the end of the barrel to be operated upon, and the two heads J are set in operation by motion derived from the main shaft S, as before explained. When these heads are retiring, a barrel-body which has been set up by hand, with the staves which compose it held in place by the bilge-hoops 9

and end hoops 10, is rested upon the skids D in the center of the machine. As the heads J move forward and approach each other the shoulders *u* of the arms *r* engage the outer edge of the end hoops 10, and the ends of the curved arms Y in like manner bear against the bilge-hoops 9. As the heads J advance to and reach their greatest extent of motion the said hoops are forced onto the barrel-body to their appropriate positions, and the stave ends impinging against the inner faces of the heads J are driven lengthwise thereby until they are perfectly evened or plumed. The end hoops are forced onto the barrel-body, so as to expose about one and one-eighth inch of the stave ends, and the bilge-hoops are forced toward the center until their resistance overcomes the power of the springs Z, when the ring X recedes, carrying with it the curved arms Y. The power of these springs may be regulated by adjustments, as is well understood, and thus the position of the bilge-hoops be determined. The range of motion of the heads is fixed by the adjustable bearings of the shafts *a*, which carry their actuating cams, and thus different-sized barrels may be trussed in the same machine.

If from any cause it is desired to stop the inward stroke of the heads J, their actuating mechanism may be reversed by the rod T, as is apparent. When their return movement releases a barrel-body from their embrace it may be removed and be chamfered, crozed, provided with its permanent hoops, and headed.

What I claim is—

1. The elastically-seated trussing-arms, substantially as shown and described.
2. In a barrel-trussing machine, the combination of two reciprocating trussing-heads, which move to and from each other over the barrel ends, a driving-shaft, and two cams driven by the latter to simultaneously and uniformly actuate said trussing-heads, substantially as described.
3. The combination of head J, ring X, springs Z, arms Y, and slotted holders 8, substantially as described and shown.
4. The combination of the ring X, slotted arms Y, slotted holders, and connecting-pin 6, substantially as shown and described.

In testimony whereof I have signed my name to this specification in the presence of two subscribing witnesses.

HENRY U. PALMER.

Witnesses:

H. P. MUNSON,
JOHN C. FOSTER, Jr.