

R. H. GUYER.  
VEHICLE-SEAT SPRING.

No. 195,122.

Patented Sept. 11, 1877.

Fig. 1.

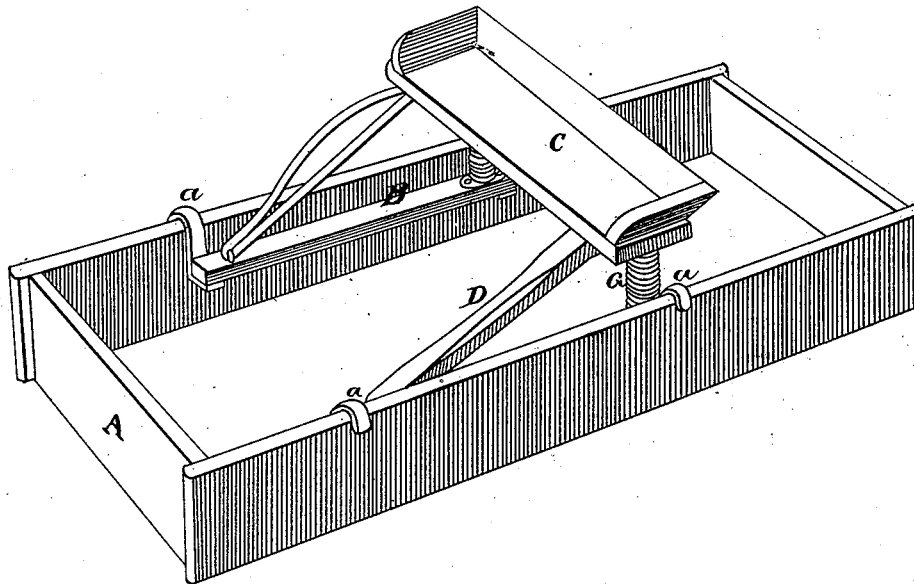
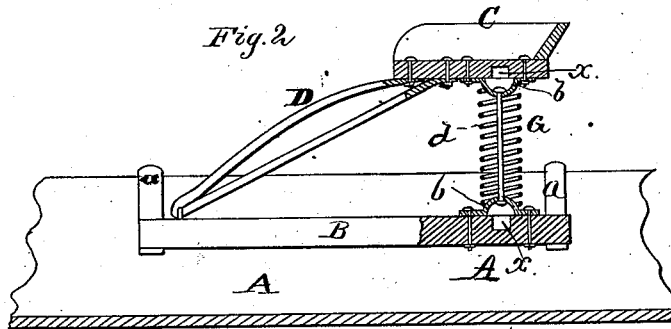

Fig. 2.



WITNESSES

*Henry N. Miller*  
*Wm. Hall*

INVENTOR

*R. H. Guyer,*  
*Alexander Watson*  
ATTORNEYS

# UNITED STATES PATENT OFFICE.

RICHARD H. GUYER, OF LA FAYETTE, INDIANA.

## IMPROVEMENT IN VEHICLE-SEAT SPRINGS.

Specification forming part of Letters Patent No. 195,122, dated September 11, 1877; application filed August 13, 1877.

*To all whom it may concern:*

Be it known that I, RICHARD H. GUYER, of La Fayette, in the county of Tippecanoe and in the State of Indiana, have invented certain new and useful Improvements in Vehicle-Seat Spring; and do hereby declare that the following is a full, clear, and exact description thereof, reference being had to the accompanying drawings, and to the letters of reference marked thereon, making a part of this specification.

My invention relates to vehicle-seat springs; and it consists in the construction and general arrangement of two coil-springs placed under the two back corners of the seat, and resting on spring-bars, which are supported by hooks at either end, and two levers extending from the springs to the forward ends of the spring-bars, as will be hereinafter more fully set forth.

In order to enable others skilled in the art to which my invention appertains to make and use the same, I will now proceed to describe its construction and operation, referring to the annexed drawing, in which—

Figure 1 is a perspective view of my invention. Fig. 2 is a longitudinal vertical section of the same.

A represents the body of the vehicle. B B are two spring-bars, supported by means of hooks *a a* at their ends on the inside of the body A, as shown. C is the seat, to the under side of which are rigidly fastened two levers, D D, the front ends of which are hinged to the spring-bars B B by any suitable hinges. These levers may be made of wood or metal, as desired.

The seat is supported upon spiral springs G G, which are held in position by means of flanged hollow thimbles or hollow nipples *b b*, fitting inside of the ends of the springs, and connected with a bolt or rivet, *d*. These hollow thimbles or nipples should be of sufficient depth to allow the bolts or rivets to telescope when the springs are closed down. The springs are fastened to the under side, near the back of the seat, with bolts, rivets, or screws through the flanges in the thimbles, and they are in like manner fastened to the spring-bars B B.

Recesses may be made opposite the thimbles in the seat and spring-bars, as shown at *x x* in Fig. 2, for the ends of the bolts *d* to enter when the springs are down.

Having thus fully described my invention, what I claim as new, and desire to secure by Letters Patent, is—

1. The combination of the springs G, hollow thimbles or nipples *b*, and the bolts or rivets *d* with the seat and supporting-bars, as set forth.

2. The combination, with the seat, of the springs G, levers D, and suspended spring-bars B, all constructed substantially as and for the purposes herein set forth.

In testimony that I claim the foregoing I have hereunto set my hand this 18th day of July, 1877.

RICHARD H. GUYER.

Witnesses:

WILLIAM S. HAGGARD,  
RICHARD H. GODMAN.