

W. H. HICKS.
BOTTLE-CLOSING DEVICES.

No. 195,127.

Patented Sept. 11, 1877.

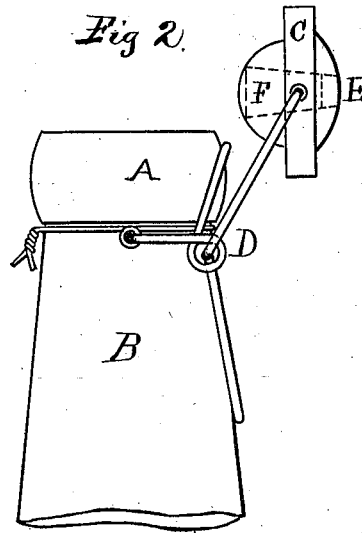
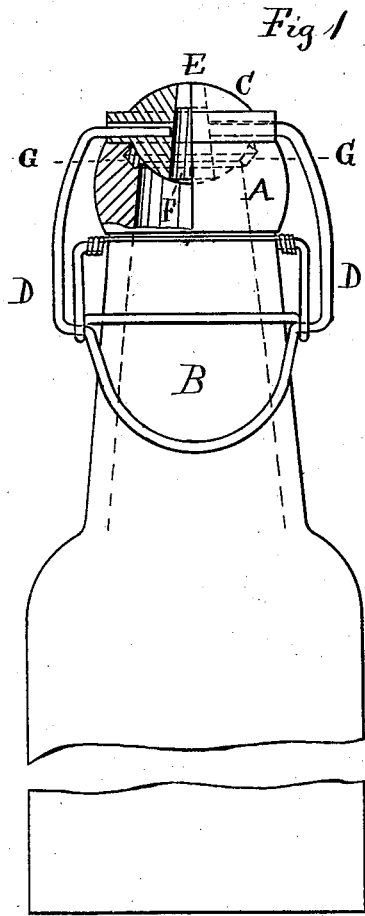

Witnesses
James M. Hicks
William G. Jenkins

Inventor
W. H. Hicks

UNITED STATES PATENT OFFICE.

WILLIAM H. HICKS, OF BROOKLYN, NEW YORK.

IMPROVEMENT IN BOTTLE-CLOSING DEVICES.

Specification forming part of Letters Patent No. 195,127, dated September 11, 1877; application filed May 25, 1877.

To all whom it may concern:

Be it known that I, WILLIAM H. HICKS, of Brooklyn, county of Kings, and State of New York, have invented Improvements in Bottle-Closing Devices, of which the following is a specification, reference being had to the drawings, which form part of this specification.

My invention relates to closing devices which operate by a leverage mechanism attached under a shoulder, and also jointed to the stopper, to close it upon a packing between the stopper and the inner walls of a bottle to make a tight joint, the stopper being so constructed and arranged that the bottle can be filled, or not, through an opening in the stopper, closible or closed by a stopper or valve, which is made tight by pressure from within the bottle.

My invention consists in certain combinations of the following elements: A closing leverage or mechanism jointed to a stopper, and attached to the bottle beneath a shoulder; a cap-piece or stopper jointed to a closing mechanism, having its under surface provided with a curved or tapering portion projecting from it, and provided with an opening through it, closed by a valve or stopper operating against a valve seat or surface by pressure; a packing ring or piece, compressible between the curved or tapering portion of the stopper and the inner walls of the mouth of a bottle.

To enable those skilled in the arts to make and use my invention, I will proceed to describe it, referring to the drawings, in which the same letters, wherever they occur, indicate like parts.

Figure 1 is a vertical part section and part outside view of a bottle provided with my device, showing the bottle closed. Fig. 2 is a vertical side view of same, showing the bottle unclosed.

A is the mouth of a bottle; B, the neck; C, the solid cap-piece, with a curved under portion; D, the closing-leverage; E, a tapering opening through the stopper, closed by a cork, F. G is a compressible packing-ring, seated in the mouth of the bottle, on its inner walls, which may be attached to the stopper or bottle, as shown.

The operation of my invention is as follows:

The closing-leverage is attached to the bottle under the shoulder on its neck, and also connected to the stopper, so that by depressing the leverage the stopper will be drawn down upon the packing in the neck of the bottle. When this has been done the bottle is filled with liquid, under pressure, by the usual means, through the hole in the stopper. The cork F is compressed into said hole, and held firmly against its seat by the pressure from the liquid.

When still liquids are used the bottle is filled first and the stopper closed over it afterward. For this purpose no hole through the stopper is needed.

The contents are discharged by releasing the closing-leverage, when the pressure of the liquid will throw off the stopper from the mouth of the bottle, where it is held by the operator.

The stopper can be made of metal, wood, or glass, or of combined materials, the wood having been made impervious to liquid. By using a narrow packing-ring I present very little surface to the action of the liquid.

Having now described my invention, what I claim as my invention, and desire to secure by Letters Patent, is—

1. The combination, substantially as hereinbefore described, of a stopper for a bottle having a portion of its under surface curved or tapering downward toward its center, a compressible packing-ring on the inner walls of the neck of a bottle, with a closing mechanism, substantially as described, attached under the shoulder of a bottle and jointing to said stopper, all arranged to operate substantially in the manner and for the purposes set forth.

2. The combination, substantially as hereinbefore described, of a stopper for a bottle having a portion of its under surface curved or tapering downward toward its center, and an opening through it closed by a stopper, a compressible packing piece or ring held within the mouth of the bottle, with a closing mechanism, substantially as described, attached beneath the shoulder of a bottle, all arranged to operate substantially in the manner and for the purposes set forth.

3. A stopper for a bottle arranged to be

closed upon the mouth of a bottle by a closing mechanism, substantially as described, and provided with a surface on its under side tapering or curved downward toward its center, to compress the packing between the said tapering or curved surface and the inner walls of the mouth of the bottle, and an opening through it to be closed by a valve or stopper, all arranged to operate substantially in the manner and for the purposes set forth.

4. A bottle provided on the inner walls of its neck, near its mouth, with a seat arranged

to hold a compressible packing, with its inner diameter tapering upward and outward from the center-line of the bottle, and arranged to be compressed downward and outward by a tapering or curved stopper pressed upon it from the outside of the bottle to make a tight joint, substantially as and for the purposes set forth.

W. H. HICKS.

Witnesses:

WILLIAM G. JENKINS,
JAMES M. HICKS.